

Pacific Region Tacoma Washington
 New Generation Delivery Vehicle (NGDV)
 Vehicle Maintenance Facility (VMF)
 RFP No.: 30902332.02203R
 USPS Project No.: E10234

Contract No.: 104267-21-B-0030

WSP-Korte Project No. 30902332.02203

Addendum No. 2 – 5.9.2024

To: All Bidders
 From: WSP-Korte,
 Subject: **RFP 30902332.02203**
 Re: **Tacoma
 NGDV VMF Upgrades**

Dear Bidders,

The changes found within are hereby made effective as though originally issued with the RFP BidPackage. All other subjects remain the same.

Addendum No. 2

Technical Section

1. Technical

- a. Questions received with Answers: None
- b. Design Update Summary
- c. Design Update – Architectural
- d. Design Update – Civil
- e. Design Update – Electrical
- f. Design Update – Specifications
- g. RFI Log – Curb Clarification

2. Contracts and Procurement Section

- a. Questions Received with Answers: None
- b. Updated Bid Due Date Extension on or before COB 5pm (EDT) – **May 22, 2024.**

3. Documents in Amendment Folder (7 total):

- a) Addendum No.2 RFP 30902332.02203 (This Document)
- b) 20240503_Revision 2 (Design Update Summary)
- c) TACOMA - VMF__548330-005_90DesignArch_002 (Design Update – Arch.)
- d) 20240503_CIVIL_TACOMA_VMF_R02_DONE (Design Update – Civil)
- e) TACOMA VMF_548331_984DesignElec_2024.05.03b (Design Update Elect.)
- f) TACOMA - VMF__548330-005_90Design_002_SPECS (Design Update – Specs)

g) RFP 30902332.02203R Tacoma RFI log - 5-8-2024

***** Each Bidder must acknowledge receipt and acceptance of this addendum by close of business (COB) – 5/10/2024. Email to wspkorteuspsrfp@wsp.com. **Must include RFP # Name of Project in Subject line.**

Name of Company: Hilger Construction, Inc.
Authorized Signature: 
Print Name and Title: Ian Hilger, Vice President

Tacoma VMF

Drawings:

Revision #2

05/03/2024

General Drawing list:

G002

- Revised general note 20 to include: DO NOT PAINT OVER "UL", "FM", OR SIMILAR LABELS, INCLUDING MECHANICAL AND ELECTRICAL NAME PLATES.
- Revised general note 23 to reflect 16'-3" clearance height.

Arch Drawing list:

A001

- Updated new overhead door and frame finish to indicate: FACTORY POWDER COAT TO MATCH EXIST.

AD150

- Revised keynote 160 to indicate: ALL UTILITIES, FIXTURES, MECHANICAL SYSTEMS OR ANY OBSTRUCTIONS WITHIN LIFT SERVICE AREAS SHALL BE RELOCATED ABOVE 16' - 3" A.F.F.

A150

- Revised keynote 260 to indicate: ALL UTILITIES, FIXTURES, MECHANICAL SYSTEMS OR ANY OBSTRUCTIONS WITHIN LIFT SERVICE AREAS SHALL BE RELOCATED ABOVE 16' - 3" A.F.F.

Civil Drawing list:

C200

1. Added ADA Parking

C500

2. Updated details
3. Added ADA parking details

Elec Drawing list:

E001

- Added note 6 to B. Electrical Equipment Notes
- Updated clearance above lifts in Note H. 2 Post Lift Coordination

ED100

- Updated clearance above lifts in Legend Notes

E100

- Updated clearance above lifts in Legend Notes
- Lighting Fixtures are slightly shifted down in the east side of the room in the Service Bay area

ES100

- Added legend note 4

E400

- Updated ampacity based to 60 deg on Wire and Conduit Schedule

SPECIFICATIONS:

§ 000010 Table of Contents

- Modified table of contents to reflect revised and removed sections in Revision 2 submittal.

§ 011000 Summary of Work

- Revised for Revision 2

§ 083323 Overhead Coiling Doors

- Revised finish to be shop powder coated.

§ 099100 Painting

- Removed conduit from do not paint item list.

GENERAL NOTES

- DESIGN IS BASED OFF USPS STANDARD CONSTRUCTION DETAILS AND SPECIFICATIONS. THE CONTRACTOR IS RESPONSIBLE TO POSSESS AND TO BE FAMILIAR WITH THESE DOCUMENTS AND SCHEDULING REQUIREMENTS APPLICABLE TO THE PROJECT.
- DESIGN HAS INCORPORATED STATE AND LOCAL DESIGN STANDARDS, SPECIFICATIONS, AND CODES. THE CONTRACTOR IS RESPONSIBLE TO POSSESS AND TO BE FAMILIAR WITH THESE STANDARDS, REFERENCE DOCUMENTS, AND SCHEDULING REQUIREMENTS APPLICABLE TO THE PROJECT.
- ALL WORK SPECIFIED AS A DEPARTMENT OF TRANSPORTATION ITEM SHALL BE GOVERNED BY THE WASHINGTON DEPARTMENT OF TRANSPORTATION CONSTRUCTION AND MATERIAL SPECIFICATIONS AS WELL AS THE CURRENT EDITION OF THE LOCAL JURISDICTION STORM WATER MANAGEMENT MANUAL. IT IS THE CONTRACTOR'S RESPONSIBILITY TO POSSESS AND TO BE FAMILIAR WITH APPLICABLE SECTIONS.
- THESE CONTRACT DRAWINGS SHALL BE MADE AVAILABLE ON SITE AT ALL TIMES AND PRESENTED UPON REQUEST.

DEMOLITION NOTES

- CONTRACTOR SHALL OBTAIN ALL REQUIRED PERMITS PRIOR TO ANY DEMOLITION PROCESS. CERTAIN ACTIVITIES ASSOCIATED WITH CONSTRUCTION WILL REQUIRE AIR PERMITS INCLUDING BUT NOT LIMITED TO MOBILE CONCRETE BATCH PLANTS, MOBILE ASPHALT PLANTS, CONCRETE CRUSHERS, LARGE GENERATORS, ETC. THESE ACTIVITIES WILL REQUIRE SPECIFIC WASHINGTON STATE OF ECOLOGY OR LOCAL GOVERNING AUTHORITIES AIR PERMITS FOR INSTALLATION AND OPERATION. CONTRACTORS MUST SEEK AUTHORIZATION FROM THE CORRESPONDING GOVERNING BODIES. FOR DEMOLITION OF ALL COMMERCIAL SITES, A NOTIFICATION FOR RESTORATION AND DEMOLITION MUST BE SUBMITTED TO THE WASHINGTON EP/ENVIRONMENT PROTECTION DIVISION) AND LOCAL GOVERNING AUTHORITIES TO DETERMINE ANY CORRECTIVE ACTIONS THAT MAY BE REQUIRED.
- DEMOLITION INCLUDES THE FOLLOWING:
 - TRANSFER BENCHMARK CONTROL TO NEW LOCATIONS OUTSIDE THE DISTURBED AREA PRIOR TO COMMENCING DEMOLITION OPERATIONS (WHEN APPLICABLE).
 - DEMOLITION AND REMOVAL OF SITE IMPROVEMENTS NECESSARY FOR THE PROPOSED CONSTRUCTION OF NEW IMPROVEMENTS.
 - REROUTING, RELOCATING, DISCONNECTING, CAPPING OR SEALING, AND ABANDONING/REMOVING SITE UTILITIES IN PLACE (WHICHEVER IS APPLICABLE).
- REMOVE AND LEGALLY DISPOSE OF ITEMS CALLED OUT TO BE REMOVED. REMOVE AND TRANSPORT DEBRIS IN A MANNER THAT WILL PREVENT SPILLAGE ON ADJACENT SURFACES AND AREAS. THOSE ITEMS INDICATED TO BE REINSTALLED, SALVAGED, OR TO REMAIN SHALL BE CLEANED, SERVICED, AND OTHERWISE PREPARED FOR REUSE. CONTRACTOR TO STORE AND PROTECT AGAINST DAMAGE. REINSTALL ITEMS IN LOCATIONS INDICATED.
- PROTECT ITEMS INDICATED TO REMAIN AGAINST DAMAGE AND SOILING THROUGHOUT CONSTRUCTION WHEN PERMITTED BY THE CONSTRUCTION MANAGER OR OWNER. ITEMS MAY BE REMOVED TO A SUITABLE PROTECTED STORAGE LOCATION THROUGHOUT CONSTRUCTION AND THEN CLEANED AND REINSTALLED IN THEIR ORIGINAL LOCATIONS. PROMPTLY REPAIR DAMAGES TO ADJACENT FACILITIES CAUSED BY DEMOLITION OPERATIONS AT THE CONTRACTORS COST.
- CONTRACTOR SHALL SCHEDULE DEMOLITION ACTIVITIES WITH THE CONSTRUCTION/PROJECT MANAGER INCLUDING THE FOLLOWING:
 - DETAILED SEQUENCE OF DEMOLITION AND REMOVAL WORK, WITH STARTING AND ENDING DATES FOR EACH ACTIVITY.
 - DATES FOR SHUTOFF, CAPPING, AND CONTINUATION OF UTILITY SERVICES.
 - IDENTIFY AND ACCURATELY LOCATE UTILITIES AND OTHER SUBSURFACE STRUCTURAL, ELECTRICAL, OR MECHANICAL CONDITIONS.
- REGULATORY REQUIREMENTS: COMPLY WITH GOVERNING EPD NOTIFICATION REGULATIONS BEFORE STARTING DEMOLITION. COMPLY WITH HAULING AND DISPOSAL REGULATIONS OF AUTHORITIES HAVING JURISDICTION.
- MAINTAIN EXISTING UTILITIES INDICATED TO REMAIN IN SERVICE AND PROTECT THEM AGAINST DAMAGE THROUGHOUT CONSTRUCTION OPERATION.
- DO NOT INTERRUPT EXISTING UTILITIES SERVING OCCUPIED OR OPERATING FACILITIES. EXCEPT WHEN AUTHORIZED IN WRITING BY OWNER'S REPRESENTATIVE AND AUTHORITIES HAVING JURISDICTION, PROVIDE TEMPORARY SERVICES DURING INTERRUPTIONS TO EXISTING UTILITIES, AS ACCEPTABLE TO OWNER AND TO GOVERNING AUTHORITIES.
- LOCATE, IDENTIFY, DISCONNECT, AND SEAL OR CAP OFF INDICATED UTILITY SERVICES SERVING THE SITE. ARRANGE TO SHUT OFF AND CAP UTILITIES WITH UTILITY COMPANIES AND FOLLOW THEIR RESPECTIVE UTILITY KILL AND CAP WORK UNTIL UTILITY DISCONNECTING AND SEALING HAVE BEEN COMPLETED AND VERIFIED IN WRITING BY THE UTILITY COMPANY.
- CONDUCT DEMOLITION OPERATIONS TO PREVENT INJURY TO PEOPLE AND DAMAGE TO ADJACENT BUILDINGS AND FACILITIES TO REMAIN. ENSURE SAFE PASSAGE OF PEOPLE AROUND DEMOLITION AREA. SAFE PASSAGE INCLUDES THE ERECTION OF TEMPORARY PROTECTION AND/OR BARRICADES AS PER LOCAL GOVERNING AUTHORITIES AND IN ACCORDANCE WITH THE CURRENT ADA REGULATIONS. USE OF EXPLOSIVES WILL NOT BE PERMITTED.
- CLEAN ADJACENT BUILDINGS AND IMPROVEMENT OF DUST, DIRT, AND DEBRIS CAUSED BY DEMOLITION OPERATIONS. RETURN ADJACENT AREAS TO CONDITION EXISTING BEFORE START OF DEMOLITION.
- PROMPTLY DISPOSE OF DEMOLISHED MATERIALS. DO NOT ALLOW DEMOLISHED MATERIALS TO ACCUMULATE ON-SITE. STORAGE OR SALE OF REMOVED ITEMS OR MATERIALS ON-SITE WILL NOT BE PERMITTED. NO BURNING OF ANY MATERIALS ON SITE SHALL BE PERMITTED.
- IT IS NOT EXPECTED THAT ASBESTOS WILL BE ENCOUNTERED IN THE COURSE OF THIS CONTRACT. IF ANY MATERIALS SUSPECTED OF CONTAINING ASBESTOS ARE ENCOUNTERED, DO NOT DISTURB THE MATERIALS. IMMEDIATELY NOTIFY THE CONSTRUCTION MANAGER AND THE OWNER.
- FILLING BELOW-GRADE AREAS: COMPLETELY FILL BELOW-GRADE AREAS AND VOIDS RESULTING FROM DEMOLITION OF PAVEMENTS, AND OTHER REMOVED ITEMS WITH SOIL MATERIALS ACCORDING TO REQUIREMENTS PER THE ON-SITE GEOTECHNICAL ENGINEER'S REPRESENTATIVE. CONTRACTOR SHALL CONTACT GEOTECHNICAL ENGINEER PRIOR TO FILLING ANY AREAS TO OBSERVE FILL PROCEDURES.
- CONDUCT DEMOLITION OPERATIONS AND REMOVE DEBRIS TO ENSURE MINIMUM INTERFERENCE WITH ROADS, STREETS, WALKS, AND OTHER ADJACENT OCCUPIED OR USED FACILITIES WITHOUT PERMISSION FROM OWNER AND AUTHORITIES HAVING JURISDICTION. PROVIDE ALTERNATE ROUTES AROUND CLOSED OR OBSTRUCTED TRAFFIC WAYS IF REQUIRED BY GOVERNING REGULATIONS.
- CONTRACTOR TO WET SAWCUT EXISTING PAVEMENT TO REMAIN AT NEXT NEAREST JOINT PRIOR TO REMOVALS OF CURB, GUTTER, PAVEMENT, ETC.
- THE CONTRACTOR SHALL REMOVE EXISTING PAVEMENT MARKINGS WITH SMALL HANDHELD GRINDERS OR SCARIFIERS OR OTHER METHODS, WITH THE APPROVAL OF THE CONSTRUCTION MANAGER. TAKE CARE DURING MARKING REMOVAL NOT TO SCAR, DISCOLOR, OR OTHERWISE DAMAGE THE PAVEMENT SURFACE. DO NOT OVERPAINT OR USE OTHER METHODS OF COVERING MARKINGS INSTEAD OF REMOVAL.
- WHEN NOTED AND ALLOWED BY THE OWNER, THE CONTRACTOR MAY RE-USE EXISTING WHEELSTOPS FOR THE PROPOSED SITE. CONTRACTOR AND CONSTRUCTION MANAGER SHALL COORDINATE WHICH EXISTING WHEELSTOPS MAY BE RE-USED PRIOR TO DEMOLITION. CONTRACTOR SHALL ENSURE THAT ALL RE-USED WHEELSTOPS ARE PROTECTED DURING CONSTRUCTION.
- CONTRACTOR SHALL FULLY SECURE WORK AREA WITH THE APPROPRIATE SIGNAGE, FENCING, AND BARRICADES WHICH ACCOMMODATE VISUALLY IMPAIRED PERSONS AS AGREED UPON WITH SITE CONSTRUCTION/PROJECT MANAGER AND OWNER TO WARN AND KEEP PEOPLE OUT OF THE SITE WORK AREA FOR THE DURATION OF THE PROJECT.

GENERAL PLAN AND SURVEY NOTES

- PRIOR TO STARTING CONSTRUCTION THE CONTRACTOR SHALL BE RESPONSIBLE FOR MAKING SURE THAT ALL REQUIRED PERMITS AND APPROVALS HAVE BEEN OBTAINED. NO CONSTRUCTION OR FABRICATION SHALL BEGIN UNTIL THE CONTRACTOR HAS RECEIVED AND THOROUGHLY REVIEWED ALL PLANS AND OTHER DOCUMENTS APPROVED BY ALL OF THE PERMITTING AUTHORITIES.
- THE CONTRACTOR'S ATTENTION IS DIRECTED TO THE SECTION OF THESE NOTES ENTITLED "GRADING PLAN NOTES."
- ALL WORK SHALL BE PERFORMED IN ACCORDANCE WITH THESE PLANS, SPECIFICATIONS AND THE REQUIREMENTS AND STANDARDS OF THE LOCAL GOVERNING AUTHORITY.
- ALL WORK WITHIN THE RIGHTS OF WAY SHALL BE IN ACCORDANCE WITH THE GOVERNING JURISDICTION AND SPECIFICATIONS.
- CONTRACTOR SHALL COORDINATE ANY MAINTENANCE OF TRAFFIC WITH THE OWNER'S REPRESENTATIVE AND THE LOCAL JURISDICTION PRIOR TO CONSTRUCTION.
- ALL WORK SHALL BE COMPLETED IN A NEAT AND ORDERLY MANNER REMOVING ALL EXCESS MATERIAL AND WASTE FROM THE SITE INCLUDING TIMELY REMOVAL OF ANY CONCRETE SPATTER. UPON COMPLETION OF PROJECT, CONTRACTOR SHALL CLEAN THE PAVED AREAS PRIOR TO REMOVAL OF TEMPORARY SEDIMENT CONTROLS, AS DIRECTED BY THE CITY AND/OR CONSTRUCTION/PROJECT MANAGER. IF POWER WASHING IS USED, NO SEDIMENT LADEN WATER SHALL BE WASHED INTO THE STORM SYSTEM. ALL SEDIMENT LADEN MATERIAL ON PAVEMENT OR WITHIN THE STORM SYSTEM SHALL BE COLLECTED AND REMOVED FROM THE SITE AT CONTRACTOR'S EXPENSE.
- THESE PROJECT CONSTRUCTION DOCUMENTS SHALL NOT CONSTITUTE A CONTRACTUAL RELATIONSHIP BETWEEN WSP CORPORATION AND THE CONTRACTOR/SUBCONTRACTOR/OTHER AFFILIATED PARTIES.
- THE ENGINEER WILL NOT BE RESPONSIBLE FOR CONSTRUCTION OR SAFETY. MEANS, METHODS, TECHNIQUES, SEQUENCES OR PROCEDURES UTILIZED IN CONSTRUCTION BY THE CONTRACTOR OR SUBCONTRACTORS. ANY SEQUENCING OR SUGGESTED NOTATIONS WHICH MAY APPEAR IN THE PLANS IS INTENDED TO ASSIST IN THE UNDERSTANDING OF PROJECT INTENT.
- DETAILS, NOTES, AND OTHER REFERENCES CONTAIN HEREIN MAY HAVE BEEN ATTAINED FROM OUTSIDE REFERENCE SOURCE LOCATIONS SUCH AS, BUT NOT LIMITED TO, LOCAL AUTHORITY AGENCIES, DESIGN REFERENCE MANUALS, MANUFACTURER'S RECOMMENDED DOCUMENTATION, OR OTHER INDUSTRY SOURCES. WSP DOES NOT WARRANT INFORMATION OR REPRESENTATION OF SAID CONTENT CONTAINED HEREIN IT IS SHOWN SOLELY FOR REFERENCE ONLY OF DESIGN INTENT AT THE TIME OF PLAN PREPARATION. THE CONSTRUCTION TEAM MEMBERS (CONTRACTOR AND CONSTRUCTION MANAGER, WHERE APPLICABLE) SHALL OBTAIN THE MOST CURRENT DETAILED INFORMATION FROM THE RESPECTIVE SOURCE TO CONSTRUCT THE IMPROVEMENTS UNDER THE AUTHORITY OF THE RESPECTIVE GOVERNING AGENCIES. IF ANY DISCREPANCIES ARE DISCOVERED BETWEEN THE ORIGINAL DESIGN INTENT AND THE CONSTRUCTION TEAM OBTAINED REFERENCE MATERIAL, THE CONSTRUCTION MANAGER OR THE PROJECT'S CONTACT PERSON SHALL BE NOTIFIED PRIOR TO COMMENCING OF ASSOCIATED WORK.
- CONDUCT CONSTRUCTION OPERATIONS TO ENSURE MINIMUM INTERFERENCE WITH ROADS, STREETS, WALKS, AND OTHER ADJACENT OCCUPIED AND USED FACILITIES. DO NOT CLOSE OR OBSTRUCT STREETS, WALKS, OR OTHER ADJACENT OCCUPIED OR USED FACILITIES WITHOUT PERMISSION FROM OWNER AND AUTHORITIES HAVING JURISDICTION. PROVIDE ALTERNATE ROUTES AROUND CLOSED OR OBSTRUCTED TRAFFIC WAYS.
- THE LOCATIONS OF UNDERGROUND FACILITIES SHOWN ON THE PLANS ARE BASED ON THE OWNER'S RECORD DRAWINGS. THE CONTRACTOR SHALL BE RESPONSIBLE TO BECOME FAMILIAR WITH THE SITES POSSIBLE BELOW-GRADE FEATURES, INCLUDING BUT NOT LIMITED TO, ROOMS, VAULTS, UTILITIES, ETC. AND SHALL CONDUCT A WALK THROUGH WITH THE OWNER'S REPRESENTATIVE. CONTRACTOR SHALL CONTACT THE VARIOUS UTILITY COMPANIES TO LOCATE THEIR FACILITIES PRIOR TO STARTING CONSTRUCTION. NO ADDITIONAL COMPENSATION SHALL BE PAID TO THE CONTRACTOR FOR REPAIR TO DAMAGE CAUSED BY THEIR WORK FORCE TO FACILITIES WHICH ARE NOT INTENDED TO BE DISTURBED.
- ALL DIMENSIONS, GRADES, AND UTILITY LOCATIONS SHOWN ON THESE PLANS WERE BASED ON OWNERS PROVIDED DATA. THE CONTRACTOR SHALL FIELD VERIFY ALL EXISTING CONDITIONS PRIOR TO CONSTRUCTION. CONTRACTOR SHALL NOTIFY CONSTRUCTION/PROJECT MANAGER IF ANY DISCREPANCIES EXIST PRIOR TO PROCEEDING WITH CONSTRUCTION FOR NECESSARY CHANGES. NO EXTRA COMPENSATION SHALL BE PAID TO THE CONTRACTOR FOR WORK HAVING TO BE REDONE DUE TO INFORMATION SHOWN INCORRECTLY ON THESE PLANS IF SUCH NOTIFICATION HAS NOT BEEN GIVEN.
- THE CONTRACTOR SHALL RUN AN INDEPENDENT VERTICAL CONTROL TRAVERSE TO CHECK BENCHMARKS AND A HORIZONTAL CONTROL TRAVERSE THROUGH THE REFERENCED PROJECT CONTROL DATUM TO CONFIRM GEOMETRIC DATA. IT IS THE CONTRACTORS RESPONSIBILITY TO NOTIFY THE CONSTRUCTION MANAGER OF ANY DISCREPANCIES PRIOR TO THE START OF CONSTRUCTION.
- FROST DEPTH OF SITE AREA IS 30".

CONCRETE NOTES AND SPECIFICATIONS

- ALL EXTERIOR SITE SPECIFIC PORTLAND CEMENT CONCRETE (PCC) (I.E. SIDEWALK, PAVEMENT OR CURBS) SHALL BE IN ACCORDANCE WITH THE LATEST EDITIONS OF THE WASHINGTON DEPARTMENT OF TRANSPORTATION (WSDOT) AND THE AMERICAN CONCRETE INSTITUTE (ACI) SPECIFICATIONS USING THE RESPECTIVE ASTM STANDARDS FOR MATERIALS USED, MIXING, TRANSPORTATION, FORMING, PLACEMENT, CURING, AND SEALING. THE MINIMUM STRENGTH FOR NORMAL WEIGHT CONCRETE SHALL BE 4000 PSI AT 28 DAY STRENGTH. CONTRACTOR SHALL REFER TO DETAILS, NOTES, AND SPECIFICATIONS WITHIN THE CONSTRUCTION DOCUMENTS FOR VARIATIONS TO THIS SPECIFICATION. MIX DESIGN SHOP DRAWINGS SHALL BE TAILORED TO THE ACTUAL FIELD PLACEMENT CONDITIONS AND BE SUBMITTED TO THE CONSTRUCTION/PROJECT MANAGER IN ACCORDANCE WITH THE PROJECT REQUIREMENTS.
- ALL EXTERIOR CONCRETE CURBS SHALL HAVE JOINTS PER ACI 330. CURB JOINTS ARE TO ALIGN WITH CONCRETE PAVEMENT JOINTS WHERE APPLICABLE, TYPICALLY BEING 10 FT TO 12 FT. ALL EXTERIOR VEHICULAR CONCRETE PAVEMENT AND FLATWORK SHALL HAVE CONTROL JOINTS PER TABLE BELOW AND EXPANSION JOINTS PER ACI 330 TYPICAL RECOMMENDATIONS.

SLAB THICKNESS- "T"	MAXIMUM JOINT SPACING
8 FEET AND LESS	8 FEET
4-5 INCHES	10 FEET
5-6 INCHES	12.5 FEET
6 INCHES-8 INCHES	15 FEET
8 INCHES-10 INCHES	15 FEET
- ALL JOINTS, INCLUDING SAWED JOINTS, SHALL BE SEALED. JOINTS SHALL BE CLEANED AND DRIED PRIOR TO SEALING. JOINT SEALING MATERIALS SHALL COMPLY WITH ASTM C 881 FOR APPLIED ELASTOMERIC, ASTM D 5893 TYPE NS FOR SILICONE RUBBER, AND TT-S-00230C FOR SINGLE COMPONENT ELASTOMERIC. SEALER WIDTH, DEPTH, AND PREPARED APPLICATION SURFACES SHALL BE PER MANUFACTURER RECOMMENDATIONS. JOINT FILLER MATERIAL SHALL CONFORM TO ASTM D1751 OR ASTM D8139 AND EXTEND THE FULL DEPTH OF CONTACTING SURFACE.
- ALL CONCRETE PANELS SHALL BE SQUARE WITH A LENGTH TO WIDTH RATIO NO GREATER THAN 1.25 TO 1 AND HAVE A MEDIUM BROOM FINISH (TRANSVERSE, SLIP RESISTANT OR PEDESTRIAN PATHWAYS) WHICH SHALL BE TO MINIMUM STRENGTH PRIOR TO OPENING FOR VEHICULAR TRAFFIC AREAS. STAGGERED/OFFSET JOINT, INTERIOR CORNERS, ANGLES LESS THAN 60 DEGREES, SLABS LESS THAN 18-INCHES WIDE, AND ODD SHAPES SHALL NOT BE PERMITTED. BLOCKOUTS AROUND ALL PAVEMENT CASTINGS SHALL BE PROVIDED IN ACCORDANCE WITH ACI RECOMMENDATIONS.
- ALL JOINTING (IF SHOWN HEREIN IS ONLY A GENERAL GUIDELINE OF DESIGN INTENT. THE CONTRACTOR SHALL BE FULLY RESPONSIBLE FOR FINAL LAYOUT OF THE JOINTING WHICH COINCIDES WITH THEIR MEANS AND METHODS TO ENSURE NO UNDESIRE CRACKS FORM THROUGH ANY PLACED CONCRETE. JOINTS SHALL BE APPROPRIATELY PLACED AS SOON AS POSSIBLE TO KEEP UNNECESSARY CRACKS FROM DEVELOPING. CONTRACTOR SHALL SUBMIT SHOP DRAWING OF THEIR PAVEMENT JOINT LAYOUT TO OWNER / CONSTRUCTION MANAGER PRIOR TO PLACEMENT FOR RECORD. THE CONTRACTOR SHALL REPLACE ANY CRACKED CONCRETE WHICH HAS NOT BEEN PLACED/FINISHED IN ACCORDANCE WITH ACI STANDARDS, TO THE NEXT JOINT PAST THE EFFECTED AREA AT NO ADDITIONAL COST TO THE PROJECT WITHIN ONE YEAR OF PROJECT COMPLETION.
- CONCRETE SHALL ARRIVE AT JOB SITE WITH APPROPRIATE W/C RATIO. NO WATER SHALL BE ADDED TO CONCRETE ON SITE WHICH EXCEEDS THE MAXIMUM ALLOWED W/C RATIO AS INDICATED BY THE WRITTEN BATCH PLANT TICKET FROM THE SUPPLIER. SUPERPLASTICIZER AND/OR OTHER ADMIXTURES MAY BE UTILIZED TO ACHIEVE DESIRED WORKABILITY OR TO ACCOUNT FOR ADVERSE PLACEMENT CONDITIONS. ADMIXTURES SHALL BE UTILIZED ONLY IN ACCORDANCE WITH THE MANUFACTURER'S WRITTEN INSTRUCTIONS AND MEET THE REQUIREMENTS OF ASTM C494 AND/OR ASTM C1017.
- CONTRACTOR SHALL HAVE A MIN. 5 YEARS EXPERIENCE WITH SUCCESSFUL PLACEMENT OF CONCRETE UTILIZING POZZOLAN MATERIALS. MIX DESIGNS WHICH UTILIZED POZZOLAN MATERIALS SHALL BE IN ACCORDANCE WITH LOCAL DOT SPECIFICATIONS AND ACI STANDARDS. FLY ASH SHALL MEET THE REQUIREMENTS OF ASTM C618, CLASS C OR CLASS F, EXCEPT THE LOSS ON IGNITION MUST NOT EXCEED 5%. SLAG CEMENT ACCORDING TO ASTM C899, GRADE 100 MINIMUM. SILICA FUME SHALL BE DRY DENSIFIED MEETING THE REQUIREMENTS OF ASTM C1249. USE OF MATERIALS SHALL BE IN ACCORDANCE WITH ACI 211.1.
- AGGREGATES SHALL BE LOW-SHRINKAGE/WELL GRADED PER ASTM C33 AND THE LOCAL DOT SPECIFICATIONS WHICH ARE RESISTANT TO FREEZE/THAW, SULFATE ATTACK, AND ARE NOT ALKALI-CARBONATE AGGREGATES OR SUSCEPTIBLE TO ALKALI-AGGREGATE REACTIVITY. SLAG AGGREGATES SHALL NOT BE PERMITTED IN ANY CONCRETE MIX.

GENERAL UTILITY NOTES

- CONTRACTOR SHALL CONTACT ALL UTILITY COMPANIES IMMEDIATELY AFTER BID IS AWARDED AND ENSURE THE UTILITY COMPANIES HAVE THE ESSENTIALS REQUIRED FOR COMPLETE SERVICE INSTALLATION. CONTRACTOR SHALL NOTIFY CONSTRUCTION MANAGER OF ANY TIME FRAMES ESTABLISHED BY UTILITY COMPANIES WHICH WILL NOT MEET OPENING DATE.
- CONTRACTOR SHALL VERIFY THE SIZE, LOCATION, INVERT ELEVATION, AND CONDITION OF EXISTING UTILITIES WHICH ARE INTENDED TO BE UTILIZED AS A CONNECTION POINT FOR ALL PROPOSED UTILITIES PRIOR TO ANY CONSTRUCTION. CONTRACTOR TO ENSURE EXISTING UTILITIES ARE IN GOOD CONDITION AND FREE FLOWING (IF APPLICABLE). IF ELEVATIONS, SIZE, OR LOCATION DIFFER FROM WHAT IS SHOWN ON PLANS, CONTRACTOR SHALL NOTIFY CONSTRUCTION MANAGER IMMEDIATELY.
- WHERE PLANS PROVIDE FOR PROPOSED WORK TO BE CONNECTED TO, OR CROSS OVER AN EXISTING SEWER OR UNDERGROUND UTILITY, THE CONTRACTOR SHALL LOCATE THE EXISTING PIPES OR UTILITIES BOTH AS TO LINE AND GRADE BEFORE STARTING THE PROPOSED WORK. IF IT IS DETERMINED THAT THE ELEVATION OF THE EXISTING CONDUIT, OR EXISTING APPURTENANCE RESULTS IN A CHANGE IN THE PLAN, THE CONSTRUCTION MANAGER SHALL BE NOTIFIED BEFORE STARTING CONSTRUCTION OF ANY PORTION OF THE PROPOSED WORK WHICH WOULD BE AFFECTED BY THE INTERFERENCE WITH AN EXISTING FACILITY. PAYMENT FOR ALL THE OPERATIONS DESCRIBED ABOVE SHALL BE INCLUDED IN THE CONTRACT PRICE FOR THE PERTINENT ITEM.
- UTILITY SERVICE PROVIDERS RULES AND REQUIREMENTS TAKE PRECEDENCE OVER INFORMATION HEREIN. IF DISCREPANCY ARISES, CONTRACTOR SHALL FULLY COORDINATE WITH UTILITY SERVICE PROVIDER PRIOR TO START OF CONSTRUCTION.

GRADING PLAN NOTES

- AT A MINIMUM ALL FILLED AREAS SHALL BE COMPACTED TO 98% OF STANDARD PROCTOR MAXIMUM DRY DENSITY PER A S.T.M. TEST D-698. MOISTURE CONTENT AT TIME OF PLACEMENT SHALL NOT EXCEED 2% ABOVE NOR 2% BELOW OPTIMUM.

DUST CONTROL NOTES

- DUST CONTROL SHALL BE MAINTAINED THROUGHOUT CONSTRUCTION. IF POSSIBLE GRADING SHALL BE DONE BY PHASING IN ORDER TO MINIMIZE THE AMOUNT OF LAND DISTURBANCE AT ONE TIME. IF PHASING IS NOT AN OPTION, DUST SHALL BE CONTROLLED WITH WATER DURING EARTHWORK OPERATIONS. AFTER EARTHWORK OPERATIONS, THE EXPOSED SOILS SHALL BE COVERED WITH STRAW OR MULCH UNTIL SEEDED.
- DUST CONTROL OR DUST SUPPRESSANTS MAY BE USED TO PREVENT NUISANCE CONDITIONS WHEN APPROVED BY THE LOCAL AUTHORITY HAVING JURISDICTION. WHEN USED, SUPPRESSANTS SHALL BE APPLIED IN ACCORDANCE WITH THE MANUFACTURER'S SPECIFICATIONS AND IN A MANNER, WHICH PREVENTS A DISCHARGE TO WATERS OF THE STATE. SUFFICIENT DISTANCE MUST BE PROVIDED BETWEEN APPLICATIONS AND NEARBY BRIDGES, CATCH BASINS, AND OTHER WATERWAYS. APPLICATION (EXCLUDING WATER) MAY NOT OCCUR WHEN RAIN IS IMMINENT AS NOTED IN THE SHORT TERM FORECAST. OIL MAY NOT BE APPLIED FOR DUST CONTROL.
- SUGGESTED METHODS OF CONSTRUCTION DUST CONTROL MAY INCLUDE THE FOLLOWING:
 - CONSTRUCTION SEQUENCING AND DISTURBING ONLY SMALL AREAS AT A TIME CAN GREATLY REDUCE PROBLEMATIC DUST FROM THE SITE. IF LAND MUST BE DISTURBED, ADDITIONAL TEMPORARY STABILIZATION MEASURES SHOULD BE CONSIDERED PRIOR TO DISTURBANCES.
 - APPLY TEMPORARY OR PERMANENT SEEDING AND MULCH TO AREAS THAT WILL REMAIN IDLE FOR OVER 14 DAYS. SAVING EXISTING TREES AND LARGE SHRUBS WILL ALSO REDUCE SOIL AND AIR MOVEMENT ACROSS DISTURBED AREAS.
 - SPRAY DISTURBED SITE WITH WATER UNTIL THE SURFACE IS WET BEFORE AND DURING GRADING AND REPEAT AS NEEDED, ESPECIALLY ON HAUL ROADS AND OTHER HEAVY TRAFFIC WATERING SHALL BE DONE AT A RATE THAT PREVENTS DUST BUT DOES NOT CAUSE SOIL EROSION. WETTING AGENTS MAY BE UTILIZED ACCORDING TO MANUFACTURERS INSTRUCTIONS.
 - GRADED ROADWAYS AND OTHER SUITABLE AREAS MAY BE STABILIZED USING CRUSHED STONE OR COARSE GRAVEL AS SOON AS PRACTICABLE AFTER REACHING AN INTERIM OR FINAL CRUSHED STONE OR COARSE GRAVEL CAN BE USED AS A PERMANENT COVER TO PROVIDE CONTROL OF SOIL EMISSIONS.
 - EXISTING WINDBREAK VEGETATION SHALL BE MARKED AND PRESERVED TO THE EXTENT POSSIBLE. SNOW FENCING OR OTHER SUITABLE BARRIER MAY BE PLACED PERPENDICULAR TO PREVAILING AIR CURRENTS AT INTERVALS OF ABOUT 15 TIMES THE BARRIER HEIGHTS TO CONTROL AIR CURRENTS AND BLOWING SOIL.
 - WHEN TEMPORARY DUST CONTROL MEASURES ARE USED, REPETITIVE TREATMENT SHOULD BE APPLIED AS NEED TO ACCOMPLISH SATISFACTORY CONTROL.
 - PAVED AREAS THAT HAVE ACCUMULATED SEDIMENT FROM CONSTRUCTION SHOULD BE CLEANED DAILY, OR AS NEEDED, UTILIZING A STREET SWEEPER OR BUCKET-TYPE ENDOLOADER OR SCRAPER.

SPILLS AND CONTAMINATION

- CONSTRUCTION PERSONNEL, INCLUDING SUBCONTRACTORS WHO MAY USE OR HANDLE HAZARDOUS OR TOXIC MATERIALS, SHALL BE MADE AWARE OF THE FOLLOWING GENERAL GUIDELINES REGARDING DISPOSAL AND HANDLING OF HAZARDOUS AND CONSTRUCTION WASTES:
 - PREVENT SPILLS
 - USE PRODUCTS UP
 - FOLLOW LABEL DIRECTIONS FOR DISPOSAL
 - REMOVE LIDS FROM EMPTY BOTTLES AND CANS WHEN DISPOSING IN TRASH
 - RECYCLE WASTES WHENEVER POSSIBLE
 - DON'T POUR INTO WATERWAYS, STORM DRAINS OR ONTO THE GROUND
 - DON'T POUR DOWN THE SINK, DOOR DRAIN OR SEPTIC TANKS
 - DON'T BURY CHEMICALS OR CONTAINERS
 - DON'T BURN CHEMICALS IN CONTAINERS
 - DON'T MIX CHEMICALS TOGETHER
- ANY DISCHARGE OF PETROLEUM OR PETROLEUM PRODUCTS OF LESS THAN 25 GALLONS ONTO A PERVIOUS SURFACE SHALL BE LEGALLY REMOVED AND PROPERLY TREATED OR PROPERLY DISPOSED OF, OR OTHERWISE REMEDIATED, SO THAT NO CONTAMINATION FROM THE DISCHARGE REMAINS ON-SITE. SPILLS OF 25 GALLONS OR MORE OF PETROLEUM PRODUCTS SHALL BE REPORTED TO THE WASHINGTON STATE DEPARTMENT OF ECOLOGY, THE LOCAL FIRE DEPARTMENT, AND THE LOCAL EMERGENCY PLANNING COMMITTEE WITHIN 30 MINUTES OF THE DISCOVERY OF THE RELEASE. ALL SPILLS WHICH CONTACT WATERS OF THE STATE MUST BE REPORTED TO THE WASHINGTON STATE DEPARTMENT OF ECOLOGY.
- SPILL REPORTING REQUIREMENTS: SPILLS ON PAVEMENT SHALL BE ABSORBED WITH SAWDUST OR KITTY LITTER AND DISPOSED OF WITH THE TRASH AT A LICENSED SANITARY LAND FILL. HAZARDOUS OR INDUSTRIAL WASTES SUCH AS MOST SOLVENTS, GASOLINE, OIL-BASED PAINTS, AND CEMENT CURING COMPOUNDS REQUIRE SPECIAL HANDLING. SPILLS SHALL BE REPORTED TO THE WASHINGTON STATE DEPARTMENT OF ECOLOGY.
- CONTAINERS SHALL BE PROVIDED FOR THE PROPER COLLECTION OF ALL WASTE MATERIAL, INCLUDING CONSTRUCTION DEBRIS, TRASH, PETROLEUM PRODUCTS AND ANY HAZARDOUS MATERIALS WASTES ON-SITE. CONTAINERS SHALL BE COVERED AND NOT LEAKING. ALL WASTE MATERIAL SHALL BE DISPOSED OF AT FACILITIES APPROVED FOR THAT MATERIAL. CONSTRUCTION DEMOLITION AND DEBRIS (CD&D) WASTE MUST BE DISPOSED OF AT THE WASHINGTON STATE DEPARTMENT OF ECOLOGY APPROVED CD&D LAND FILL.
- PROCESS WASTE WATER/LEACHATE MANAGEMENT : EPA'S CONSTRUCTION GENERAL PERMIT ONLY ALLOWS THE DISCHARGE OF STORM WATER AND DOES NOT INCLUDE OTHER WASTE STREAMS/DISCHARGES SUCH AS VEHICLE AND/OR EQUIPMENT WASHING, ON-SITE SEPTIC LEACHATE CONCRETE WASH-OUTS, WHICH ARE CONSIDERED PROCESS WASTEWATERS. ALL PROCESS WASTEWATERS MUST BE COLLECTED AND PROPERLY DISPOSED AT AN APPROVED DISPOSAL FACILITY. IN THE EVENT, LEACHATE OR SEPTAGE IS DISCHARGED, IT MUST BE ISOLATED FOR COLLECTION AND PROPER DISPOSAL AND CORRECTIVE ACTIONS TAKEN TO ELIMINATE THE SOURCE OF WASTE WATER.
- WASTES GENERATED BY CONSTRUCTION ACTIVITIES (I.E. CONSTRUCTION MATERIALS SUCH AS PAINTS, SOLVENTS, FUELS, CONCRETE, WOOD, ETC) MUST BE DISPOSED OF IN ACCORDANCE WITH LOCAL REGULATIONS. HAZARDOUS AND TOXIC SUBSTANCES ARE USED ON VIRTUALLY ALL CONSTRUCTION SITES. GOOD MANAGEMENT OF THESE SUBSTANCES IS ALWAYS NEEDED.
- NO CONSTRUCTION RELATED WASTE MATERIALS ARE TO BE BURIED OR BURNED ON-SITE.
- HANDLING CONSTRUCTION CHEMICALS: MIXING, PUMPING, TRANSFERRING OR OTHER HANDLING OF CONSTRUCTION CHEMICALS SUCH AS FERTILIZER, LIME, ASPHALT, CONCRETE DRYING COMPOUNDS, AND ALL OTHER POTENTIALLY HAZARDOUS MATERIALS SHALL BE PERFORMED IN AN AREA AWAY FROM ANY WATERCOURSE, DITCH OR STORM DRAIN.
- EQUIPMENT FUELING AND MAINTENANCE, OIL CHANGING, ETC., SHALL BE PERFORMED AWAY FROM WATERCOURSES, DITCHES OR STORM DRAINS. IN AN AREA DESIGNATED FOR THAT PURPOSE, THE DESIGNATED AREA SHALL BE EQUIPPED FOR RECYCLING OIL AND CATCHING SPILLS. SECONDARY CONTAINMENT SHALL BE PROVIDED FOR ALL FUEL OIL STORAGE TANKS. THESE AREAS MUST BE INSPECTED EVERY SEVEN DAYS AND WITHIN 24 HRS. OF A 0.5 INCH OR GREATER RAIN EVENT TO ENSURE THERE ARE NO EXPOSED MATERIALS WHICH WOULD CONTAMINATE STORM WATER. SITE OPERATORS MUST BE AWARE THAT SPILL PREVENTION CONTROL AND COUNTERMEASURES (SPCC) REQUIREMENTS MAY APPLY. AN SPCC PLAN IS REQUIRED FOR SITES WITH ONE SINGLE ABOVE GROUND TANK OF 660 GALLONS OR MORE, ACCUMULATIVE ABOVE GROUND STORAGE OF 1330 GALLONS OR MORE, OR 42,000 GALLONS OF UNDERGROUND STORAGE. CONTAMINATED SOILS MUST BE PROPERLY DISPOSED OF IN ACCORDANCE WITH LOCAL GOVERNING AUTHORITY REGULATIONS. SPCC PLAN AND APPROVALS ARE THE RESPONSIBILITY OF THE CONTRACTOR.
- CONTAMINATED SOILS: IF SUBSTANCES SUCH AS OIL, DIESEL FUEL, HYDRAULIC FLUID, ANTIFREEZE, ARE SPILLED, LEAKED, OR RELEASED ONTO THE SOIL, THE SOIL SHOULD BE DUG UP AND DISPOSED OF AT LICENSED SANITARY LAND FILL OR OTHER APPROVED PETROLEUM CONTAMINATED SOIL REMEDIATION FACILITY (NOT A CONSTRUCTION / DEMOLITION DEBRIS LAND FILL). NOTE THOSE STORM WATER RUNOFFS ASSOCIATED WITH CONTAMINATED SOILS ARE NOT BE AUTHORIZED UNDER CURRENT REGULATIONS OF CONSTRUCTION ACTIVITIES.
- CONTRACTOR SHALL TAKE PREVENTIVE MEASURES FOR WATER DISCHARGES FROM CONTAMINATED SOILS BY ANY MEANS POSSIBLE, INCLUDING THE FOLLOWING:
 - THE USE OF BERMS, TRENCHES, AND PITS TO COLLECT CONTAMINATED RUNOFF AND PREVENT DISCHARGES.
 - PUMPING RUNOFF INTO A SANITARY SEWER (WITH PRIOR WRITTEN APPROVAL OF THE SANITARY SEWER SERVICE OPERATOR) OR INTO A CONTAINER FOR TRANSPORT TO AN APPROPRIATE TREATMENT/DISPOSAL FACILITY.
 - COVERING AREAS OF CONTAMINATION WITH TARPS OR OTHER METHODS THAT PREVENT STORMWATER FROM COMING INTO CONTACT WITH CONTAMINATED MATERIALS.

SHEET INDEX	
SHEET NUMBER	SHEET NAME
C001	GENERAL NOTES
CD100	EXISTING CONDITIONS AND DEMOLITION PLAN
C200	PROPOSED CONDITIONS
C500	DETAILS I
C501	DETAILS II



WSP USA DESIGN INC.
27th BROADWAY,
SUITE 1000, HOUSTON,
TX 77002

TACOMA VMF
3625 S WARNER ST
TACOMA, WA 98409



90% DESIGN SUBMITTAL
05/03/2024
Revision 2





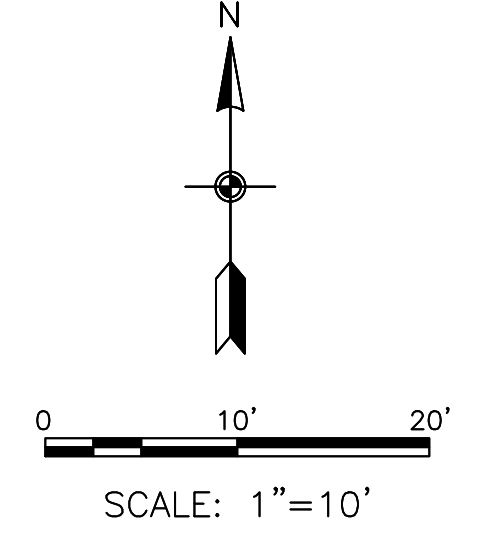
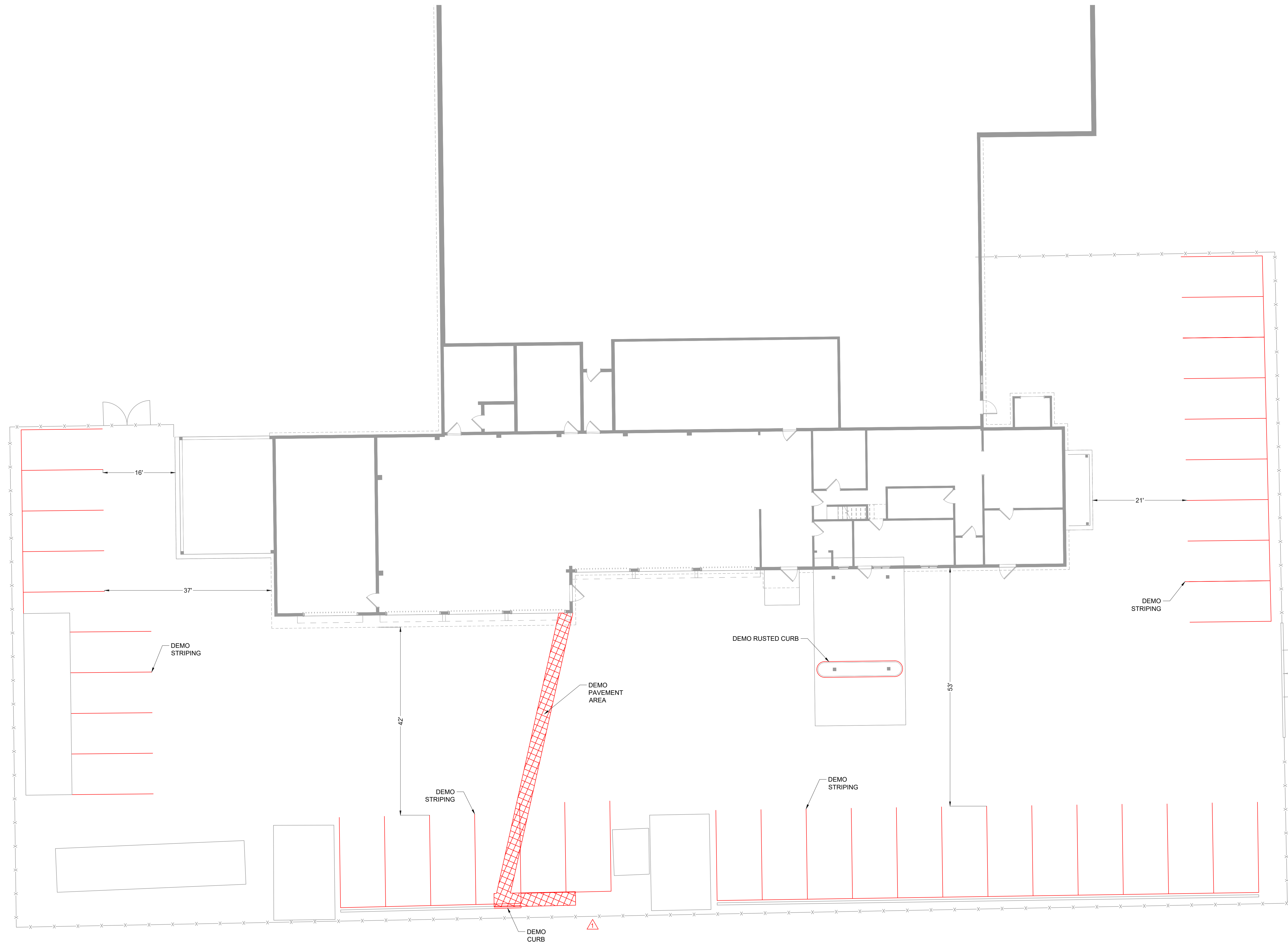

C001
Scale: AS NOTED
Project: TACOMA VMF
USPS File Number: E1024

Eastern Facilities Construction, C/IT, P.O. Box 27497, Greensboro, N.C. 27409-4927

Copyright 2008-2013, United States Postal



LEGEND

-  EXISTING GRASS AREA
-  EXISTING BUILDING
-  EXISTING PAINT STRIPING
-  EXISTING FENCE
-  EXISTING GATE
-  DEMO PAINT
-  DEMO PAVEMENT

NOTES:

1. NO TITLE SEARCH OR PROPERTY BOUNDARY SURVEY WAS COMPLETED FOR THIS PROJECT. NO BOUNDARY LINES ARE DEPICTED ON THIS DATABASE.
2. A SUBSURFACE UTILITY INVESTIGATION HAS NOT BEEN PERFORMED BY WSP. WA 811 SHOULD BE CONTACTED PRIOR TO COMMENCING ANY EXCAVATION. (800-424-5555). STORM AND SEWER CONNECTIONS WERE EXCLUDED FROM THIS SCOPE OF SERVICE AND ARE NOT SHOWN HEREON.
3. COORDINATES SHOWN BASED ON PUBLICLY AVAILABLE DATA. CONTRACTOR TO ESTABLISH BEARINGS AND COORDINATES SHOWN HEREON, IF ANY, ARE BASED ON THE WASHINGTON STATE PLANE COORDINATE SYSTEM, SOUTH ZONE, NORTH AMERICAN DATUM OF 1983.
4. ELEVATIONS SHOWN HEREON ARE BASED ON THE NORTH AMERICAN VERTICAL DATUM OF 1988 (NAVD 88) [GEOID 12B].
5. FINAL LOCATIONS TO BE FIELD VERIFIED PRIOR TO FINAL INSTALLATION. DEVIATIONS TO BE COORDINATED WITH OWNER AND ENGINEER.
6. CONTRACTOR TO DEMO ANY ADDITIONAL PAINT STRIPING ON SITE THAT CONFLICTS WITH NEW PROPOSED STRIPING.

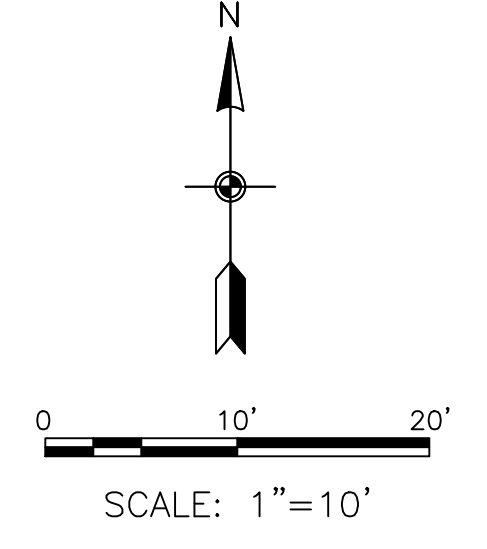

LEGEND

- EXISTING GRASS AREA
- EXISTING BUILDING
- EXISTING PAINT STRIPING
- EXISTING FENCE
- EXISTING GATE
- PROPOSED PAINT STRIPING
- PROPOSED PAVEMENT RESTORATION
- PROPOSED ACCESSIBLE PARKING
- VMF PARKING
- EMPLOYEE PARKING
- VMF CHARGER PARKING

NOTES:

1. NO TITLE SEARCH OR PROPERTY BOUNDARY SURVEY WAS COMPLETED FOR THIS PROJECT. NO BOUNDARY LINES ARE DEPICTED ON THIS DATABASE.
2. A SUBSURFACE UTILITY INVESTIGATION HAS NOT BEEN PERFORMED BY WSP. WA 811 SHOULD BE CONTACTED PRIOR TO COMMENCING ANY EXCAVATION. (800-424-5555). STORM AND SEWER CONNECTIONS WERE EXCLUDED FROM THIS SCOPE OF SERVICE AND ARE NOT SHOWN HEREON.
3. COORDINATES SHOWN BASED ON PUBLICLY AVAILABLE DATA. CONTRACTOR TO ESTABLISH BEARINGS AND COORDINATES SHOWN HEREON, IF ANY, ARE BASED ON THE WASHINGTON STATE PLANE COORDINATE SYSTEM, SOUTH ZONE, NORTH AMERICAN DATUM OF 1983.
4. ELEVATIONS SHOWN HEREON ARE BASED ON THE NORTH AMERICAN VERTICAL DATUM OF 1988 (NAVD 88) (GEOID 12B).
5. FINAL LOCATIONS TO BE FIELD VERIFIED PRIOR TO FINAL INSTALLATION. DEVIATIONS TO BE COORDINATED WITH OWNER AND ENGINEER.
6. CONTRACTOR TO REPAIR ALL SIZEABLE CRACKS ALONG EXISTING CONCRETE.
7. CONTRACTOR TO REPAINT ALL EXISTING BOLLARDS ON SITE.
8. CONTRACTOR TO RESTORE CONCRETE WHERE REQUIRED FOR CHARGER, BOLLARD, AND TRANSFORMER INSTALLATION. CONTRACTOR TO VERIFY FIELD CONDITIONS AND RESTORE AREA LIKE FOR LIKE CONDITIONS. (IE. GRASS=GRASS, CONCRETE=CONCRETE, ETC.)

PARKING SPACES		
PARKING TYPE	PROVIDED	KIT No.
EMPLOYEE PARKING	16	
VMF PARKING	16	
VMF CHARGING PARKING	2	CP001

*FINAL CHARGER SCHEDULE TO BE DEPICTED IN ELECTRICAL PLANS. ASSOCIATED CHARGER PER PARKING NUMBER TO BE DEPICTED IN ELECTRICAL PLANS.

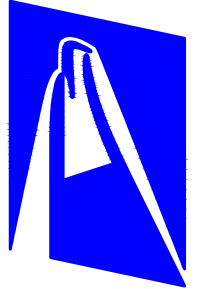
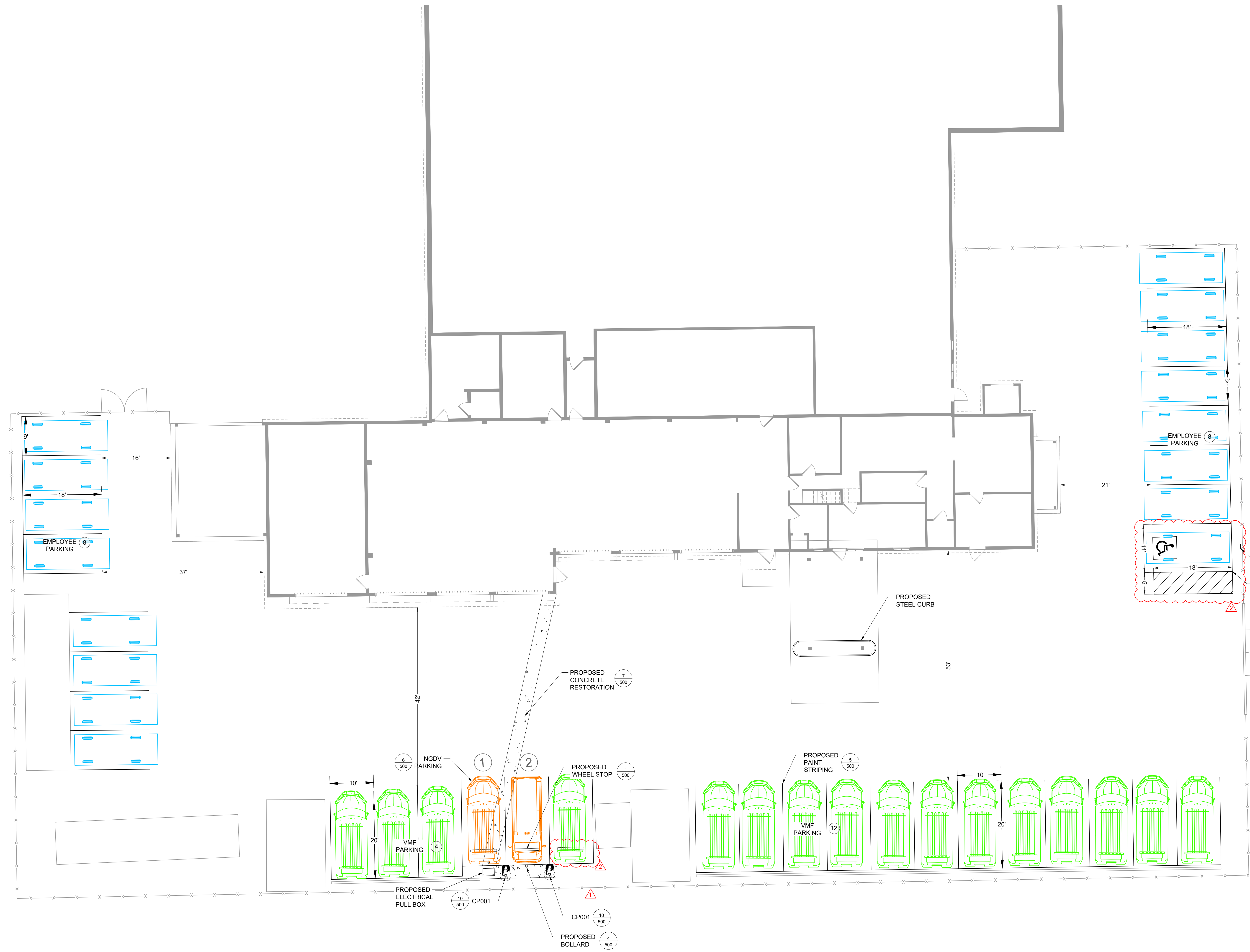

DIMENSION SUMMARY TABLE		
VEHICLE TYPE	PARKING ORIENTATION	
	REAR	FRONT
BEV ICE SPACES	4'-6"	3'-0"
BEV COTS SPACES	3'-6"	2'-9"
EMPLOYEE/RETAIL	3'-0"	3'-0"

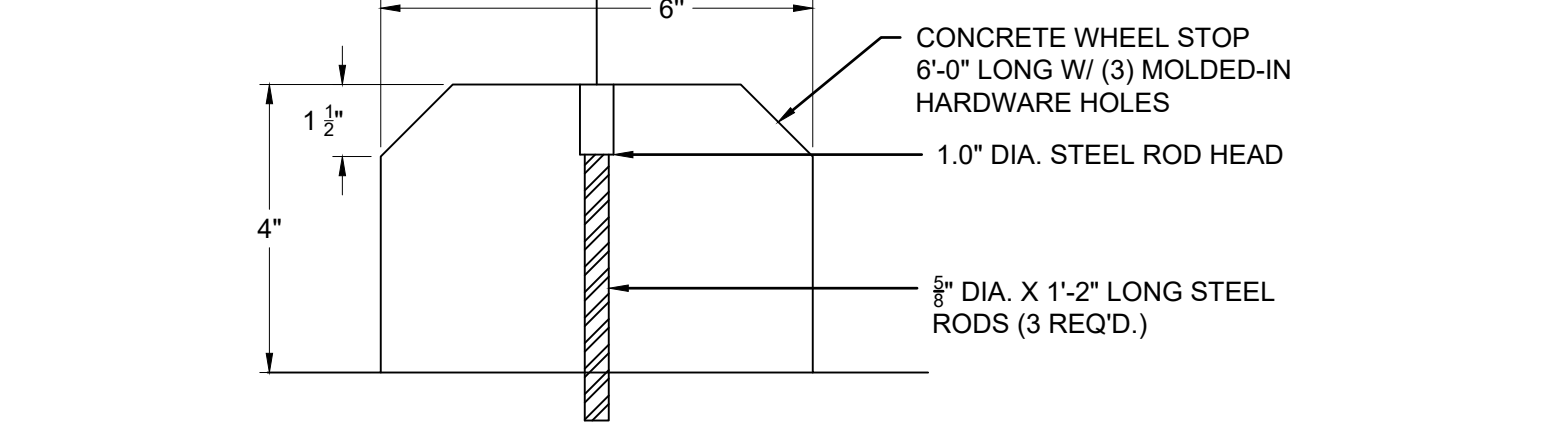

- NOTES:
- SEE SITE PLAN FOR LOCATION AND QUANTITY OF WHEELSTOPS.
 - SEE USPS PLAN AND THE PARKING ENLARGEMENTS FOR THE CAR PARKING ORIENTATIONS AS DESCRIBED IN THE 'DIMENSION TABLE' ABOVE.
 - WHEN APPLICABLE IN CONCRETE PAVEMENTS, WHEELSTOPS SHALL BE ANCHORED TO CONCRETE WITH MIN. 1/4" DROP-IN ANCHORS, 1" EMBEDMENT W/ 1/4" THREADED ROD.
 - WHEELSTOP MATERIAL AND INSTALLATION SHALL BE PER 'BARCO PRODUCTS' STANDARDS AND SPECIFICATIONS (OR APPROVED EQUAL).

1 CONCRETE WHEEL STOP
NTS

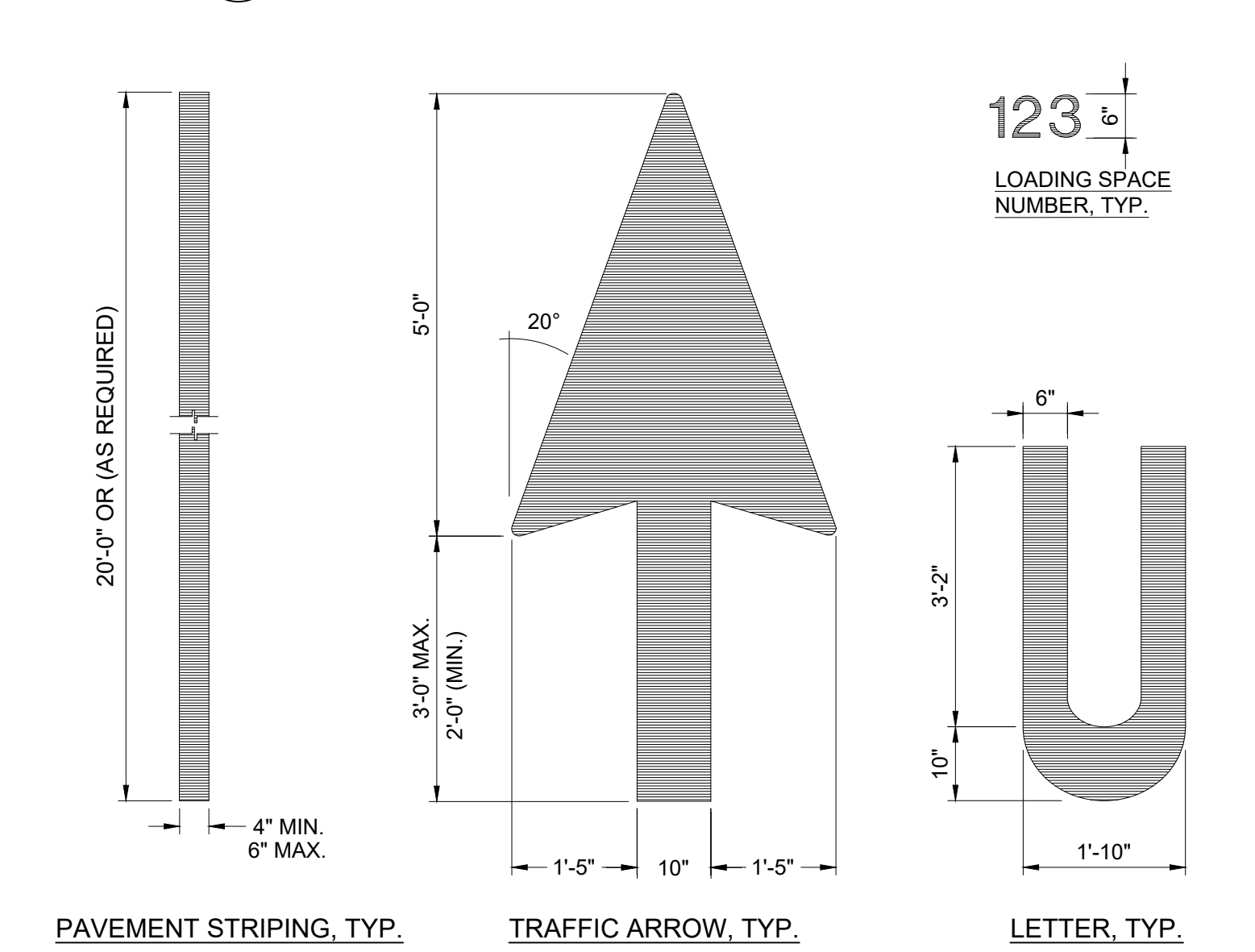

- NOTE:
- USE NON-REFLECTIVE WHITE PAINT, TYP. BUT USE YELLOW PAINT ON CONCRETE OR OTHER SURFACES WHERE WHITE PAINT DOES NOT PROVIDE SUFFICIENT CONTRAST.

5 PAVEMENT MARKINGS
NTS

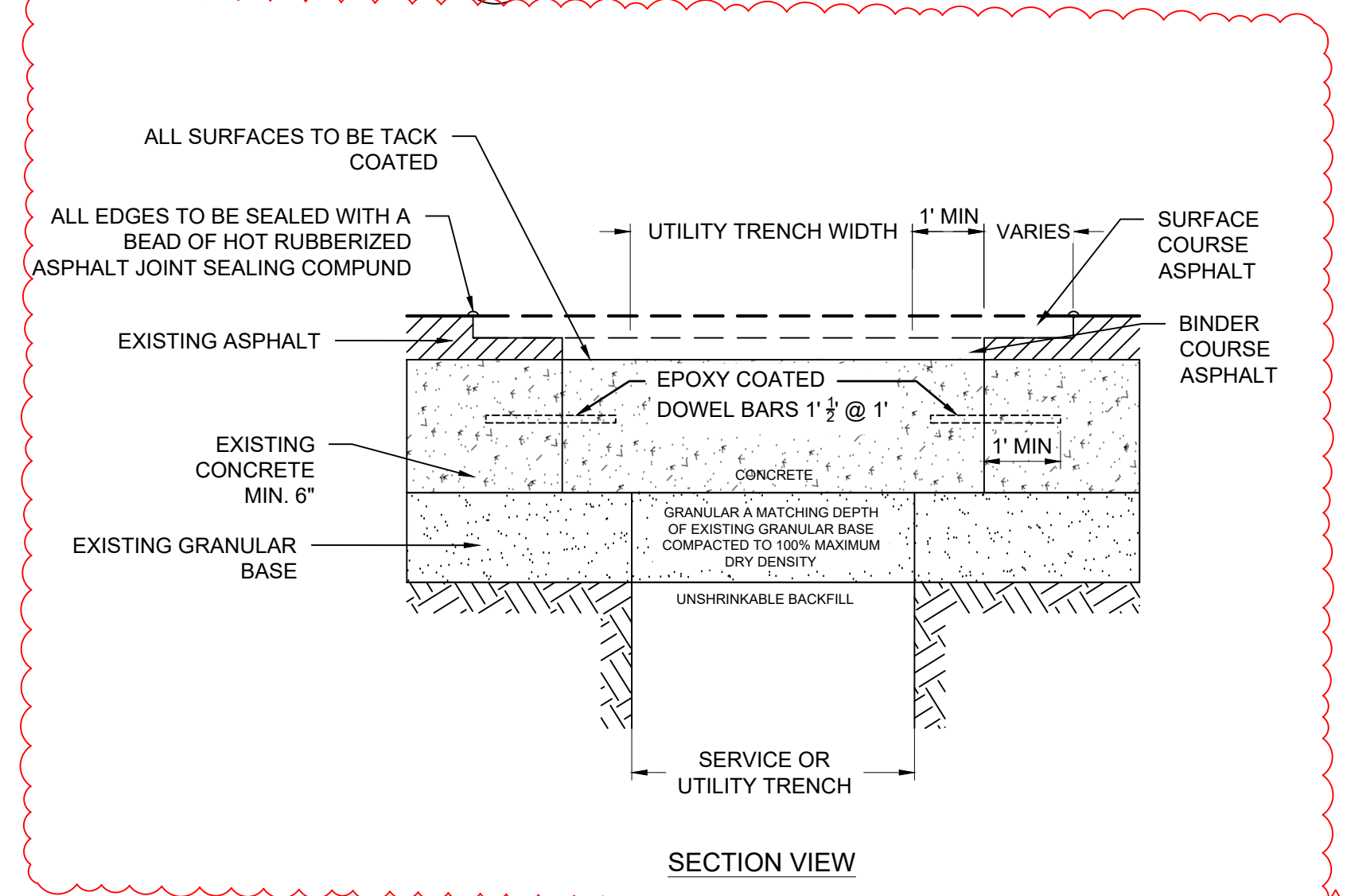

7 CONCRETE RESTORATION SECTION
NTS

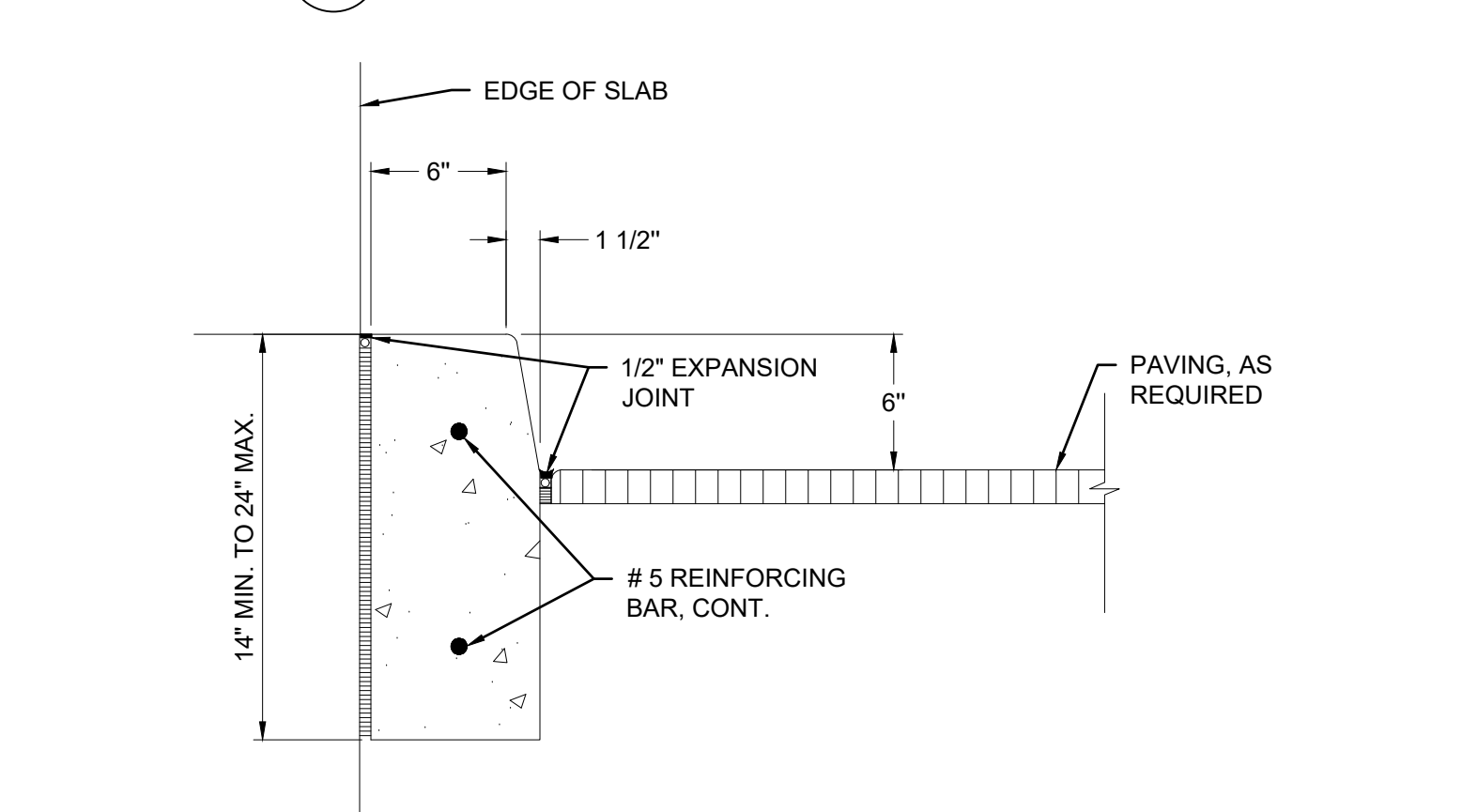

8 CURBS
NTS

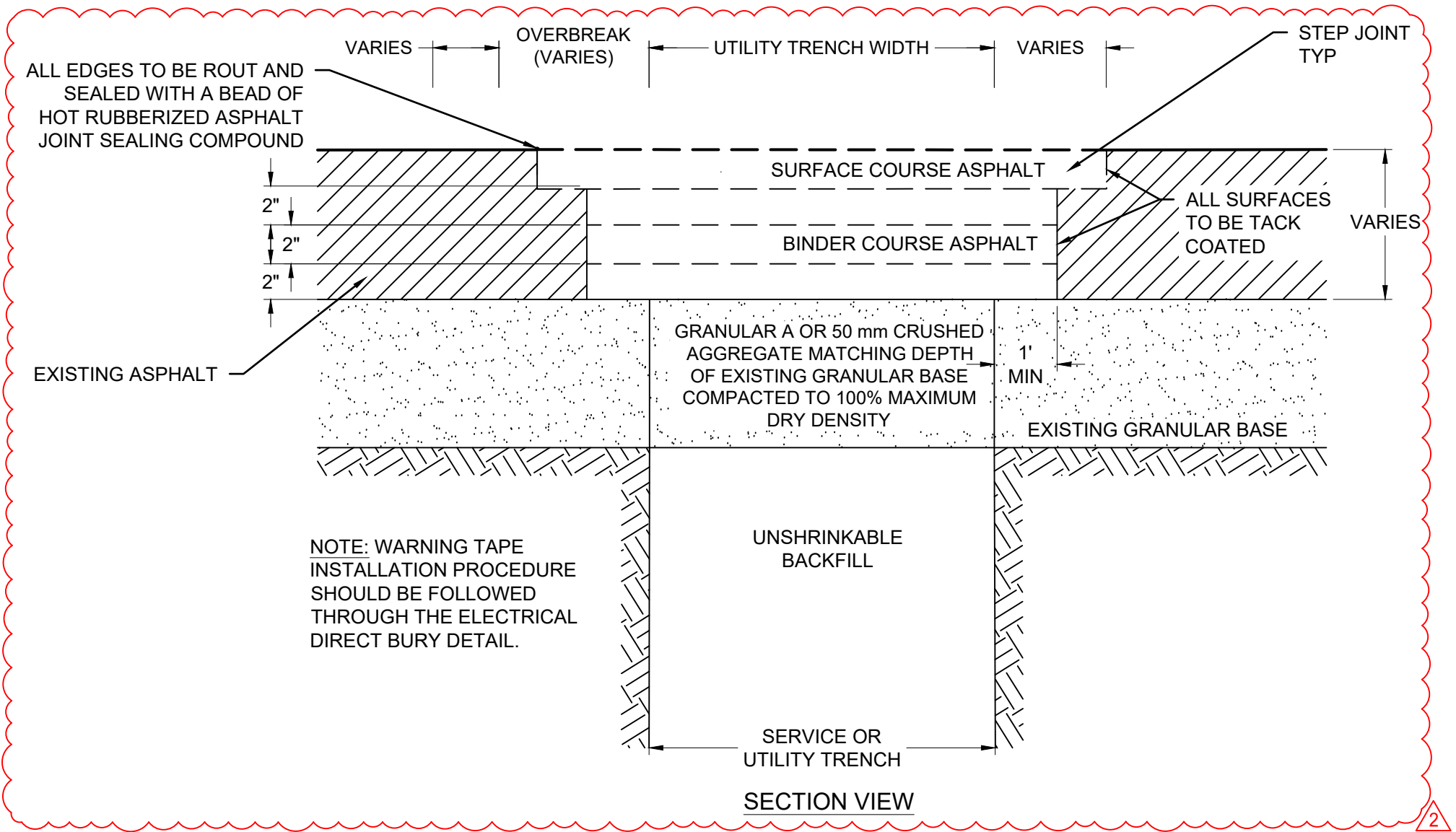

2 PAVEMENT RESTORATION SECTION
NTS

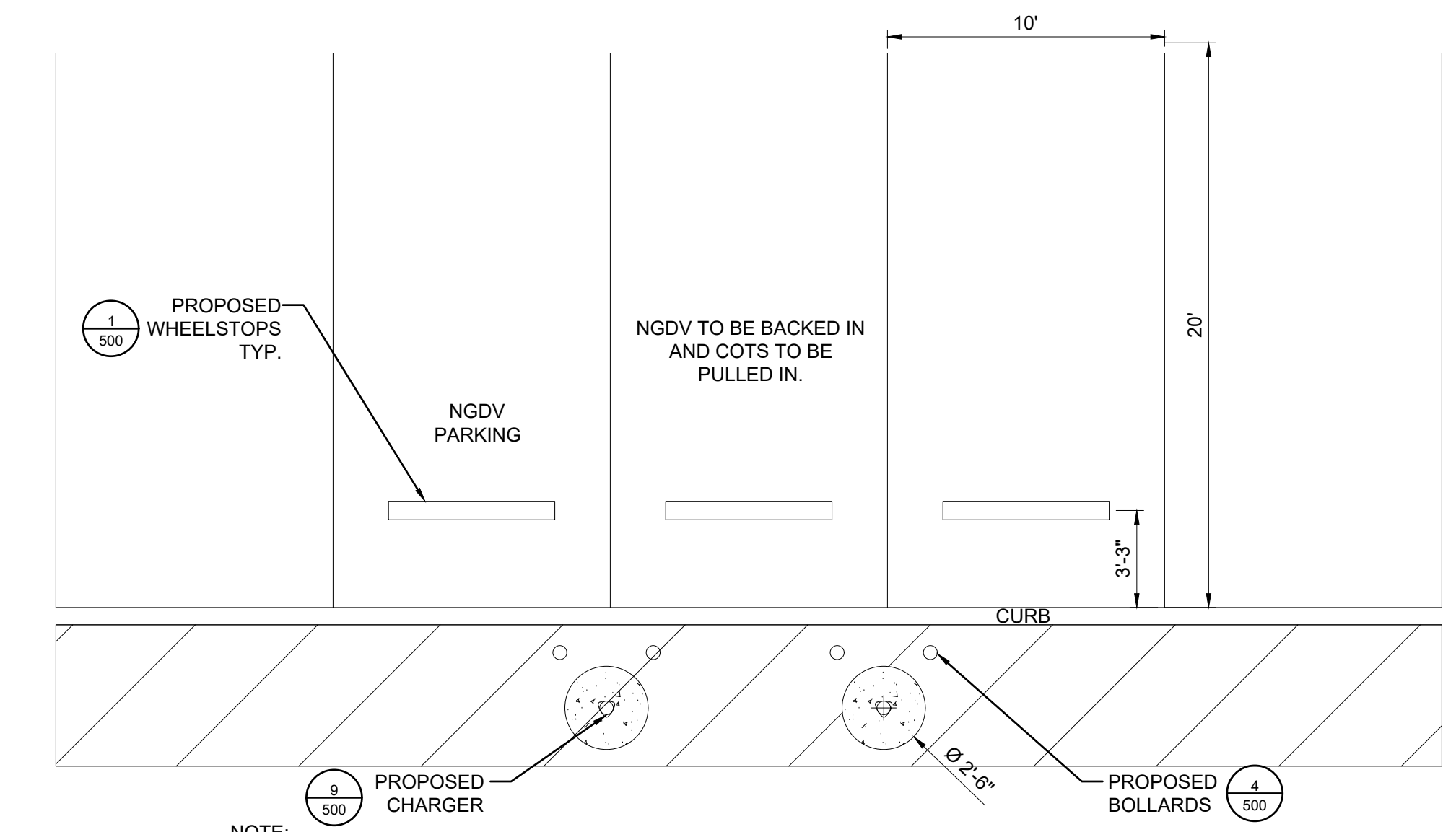

6 STANDARD NGDV PARKING DETAIL
NTS

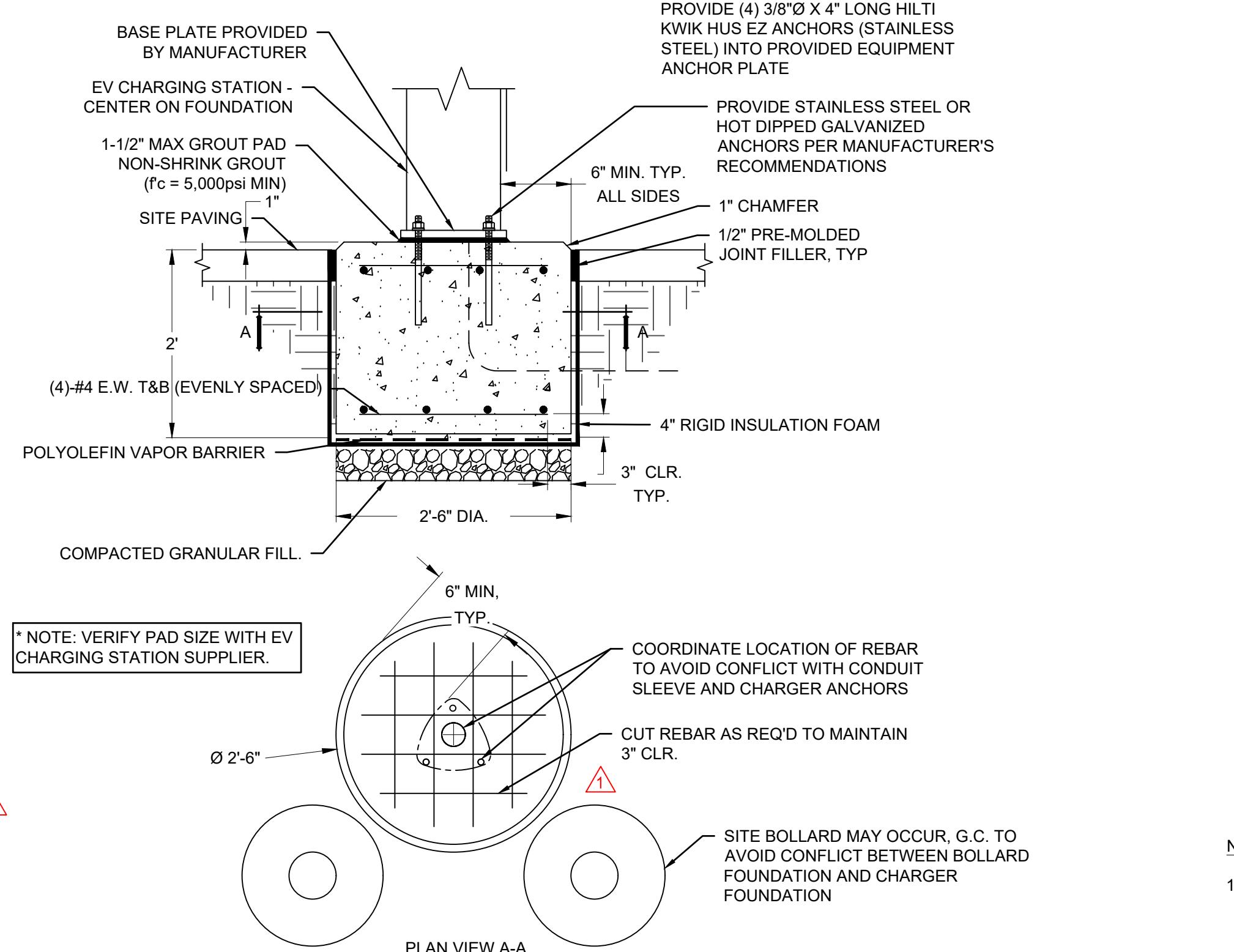

- FROST DESIGN NOTES:
- CONCRETE FOUNDATIONS SHOULD BEAR DIRECTLY ON A PROPERLY COMPACTED FREE-DRAINING GRANULAR FILL CONSISTING OF NO. 57 STONE OR AN APPROVED EQUIVALENT.
 - GRANULAR FILL SHOULD EXTEND VERTICALLY TO THE MINIMUM RECOMMENDED REGIONAL FROST DEPTH AND LATERALLY 23RD FROM THE FOUNDATION PERIMETER (EXCLUDING SIDE OF PERIMETER ADJACENT TO CURB). GRANULAR FILL SHOULD BE PLACED IN 8 INCH LOOSE LIFTS AND COMPACTED WITH A VIBRATORY COMPACTOR. THE COMPACTION EQUIPMENT SHOULD BE OPERATED OVER THE FULL WIDTH OF THE FOUNDATION UNDERCUT AREA UNTIL VISIBLE DEFORMATION OF THE BACKFILL CEASES. LOCAL FROST DEPTH IS 30 INCHES. CONTRACTOR SHALL VERIFY LOCAL FROST DEPTH WITH AHJ PRIOR TO CONSTRUCTION.
 - GEOTEXTILE (FILTER FABRIC) SHOULD BE PLACED BETWEEN THE GRANULAR BACKFILL AND COHESIVE SOILS TO PRECLUDE THE INFILTRATION OF FINES. SPEC AS FOLLOWS:
SEPARATION GEOTEXTILE: WOVEN GEOTEXTILE FABRIC, MANUFACTURED FOR SEPARATION APPLICATIONS, MADE FROM POLYOLEFINS OR POLYESTERS, WITH ELONGATION LESS THAN 50 PERCENT, COMPLYING WITH AASHTO M 288 AND THE FOLLOWING, MEASURED PER TEST METHODS REFERENCED:
SURVIVABILITY: CLASS 2, AASHTO M 288
GRAB TENSILE STRENGTH: 247 LBF (1100 N); ASTM D 4632
SEWN SEAM STRENGTH: 222 LBF (990 N); ASTM D 4632
TEAR STRENGTH: 90 LBF (400 N); ASTM D 4533
PUNCTURE STRENGTH: 90 LBF (400 N); ASTM D 4533
APARENT OPENING SIZE: NO. 60 (0.250-MM) SIEVE, MAXIMUM; ASTM D 4751
PERMITTIVITY: 0.02 PER SECOND, MINIMUM; ASTM D 4491
UV STABILITY: 50 PERCENT AFTER 500 HOURS' EXPOSURE; ASTM D 4355.

9 CHARGING STATION FOUNDATION DETAIL
NTS

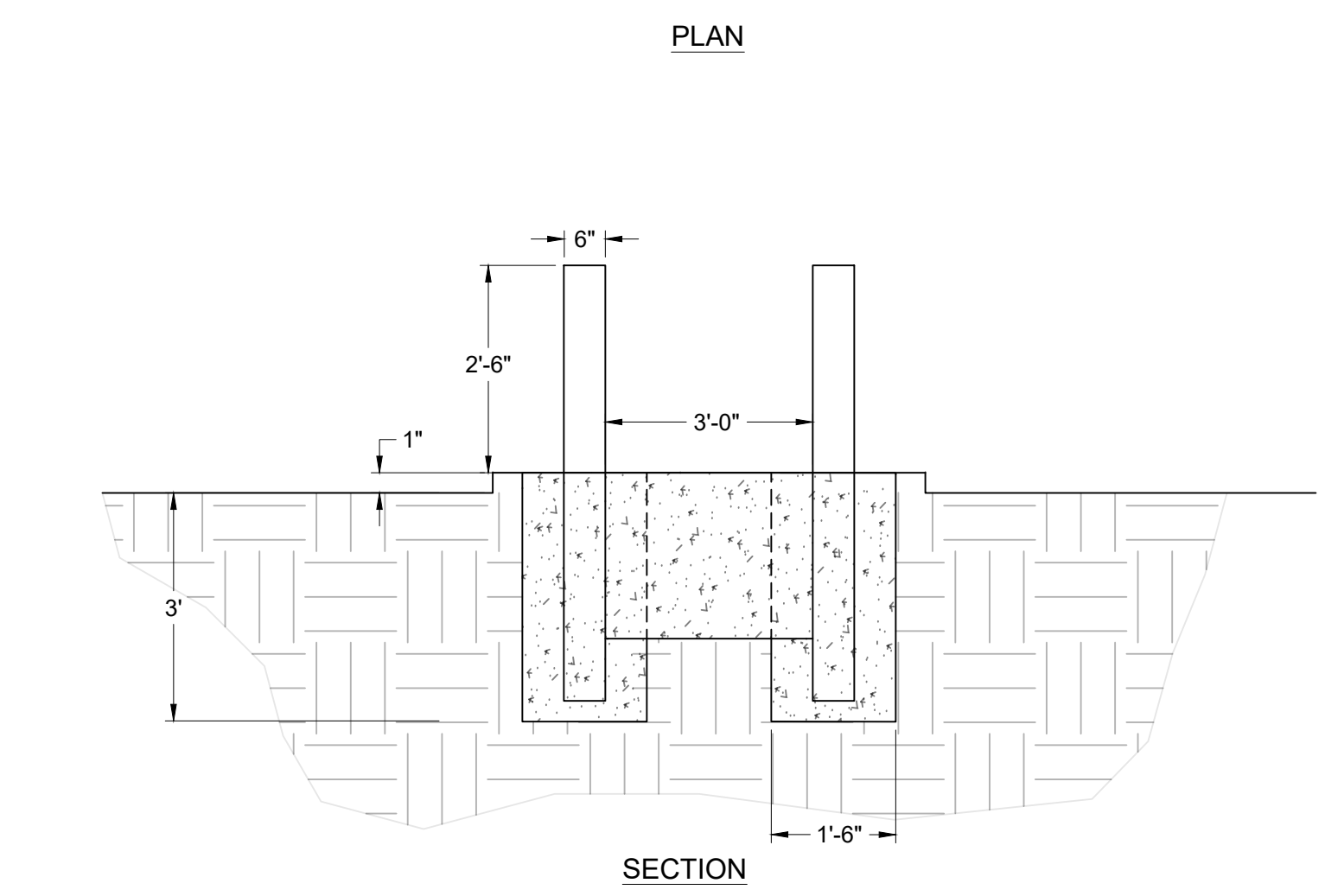
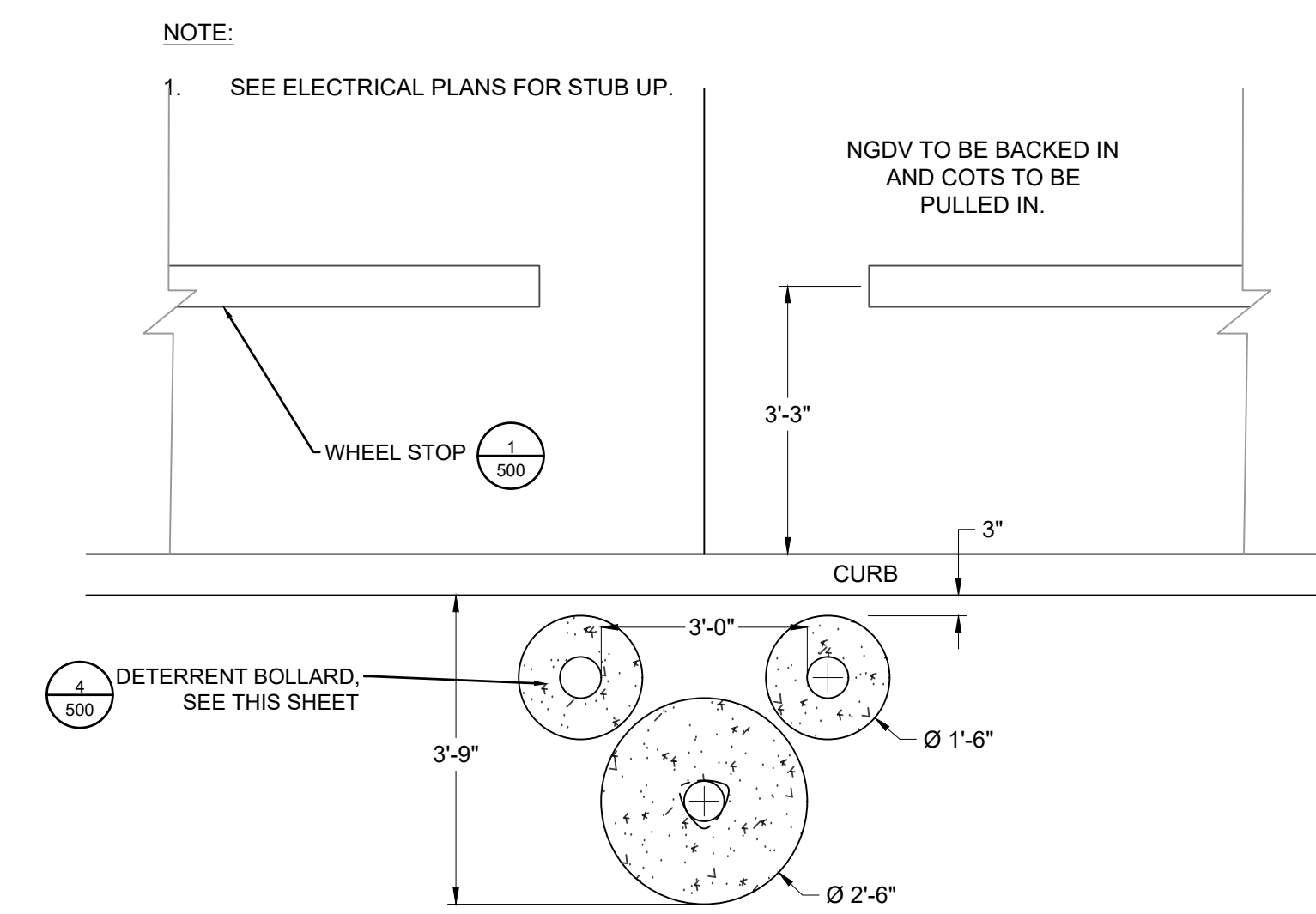

3 EV CHARGING STATION BOLLARD PROTECTION
NTS

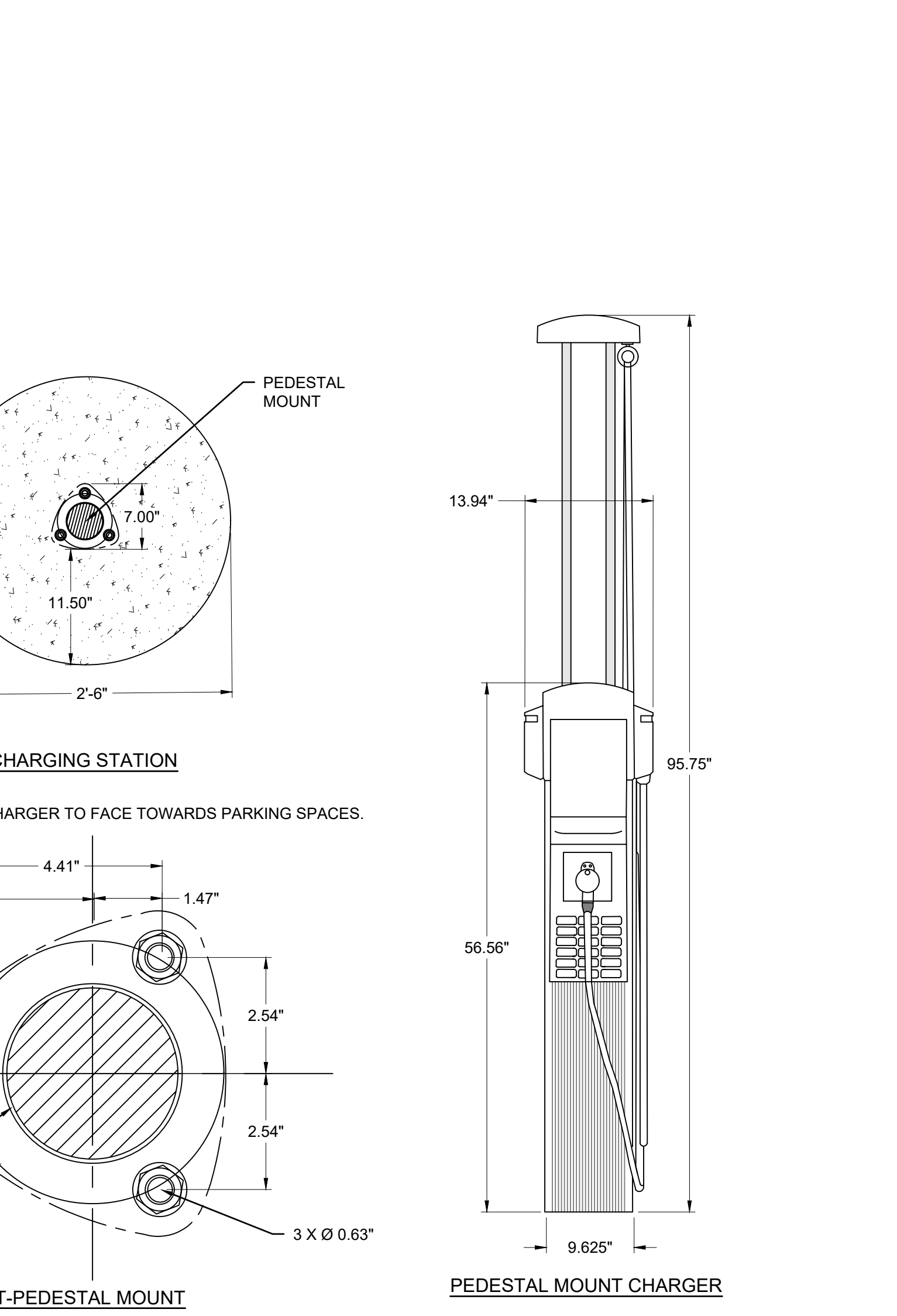

10 CHARGING STATION DETAIL
NTS

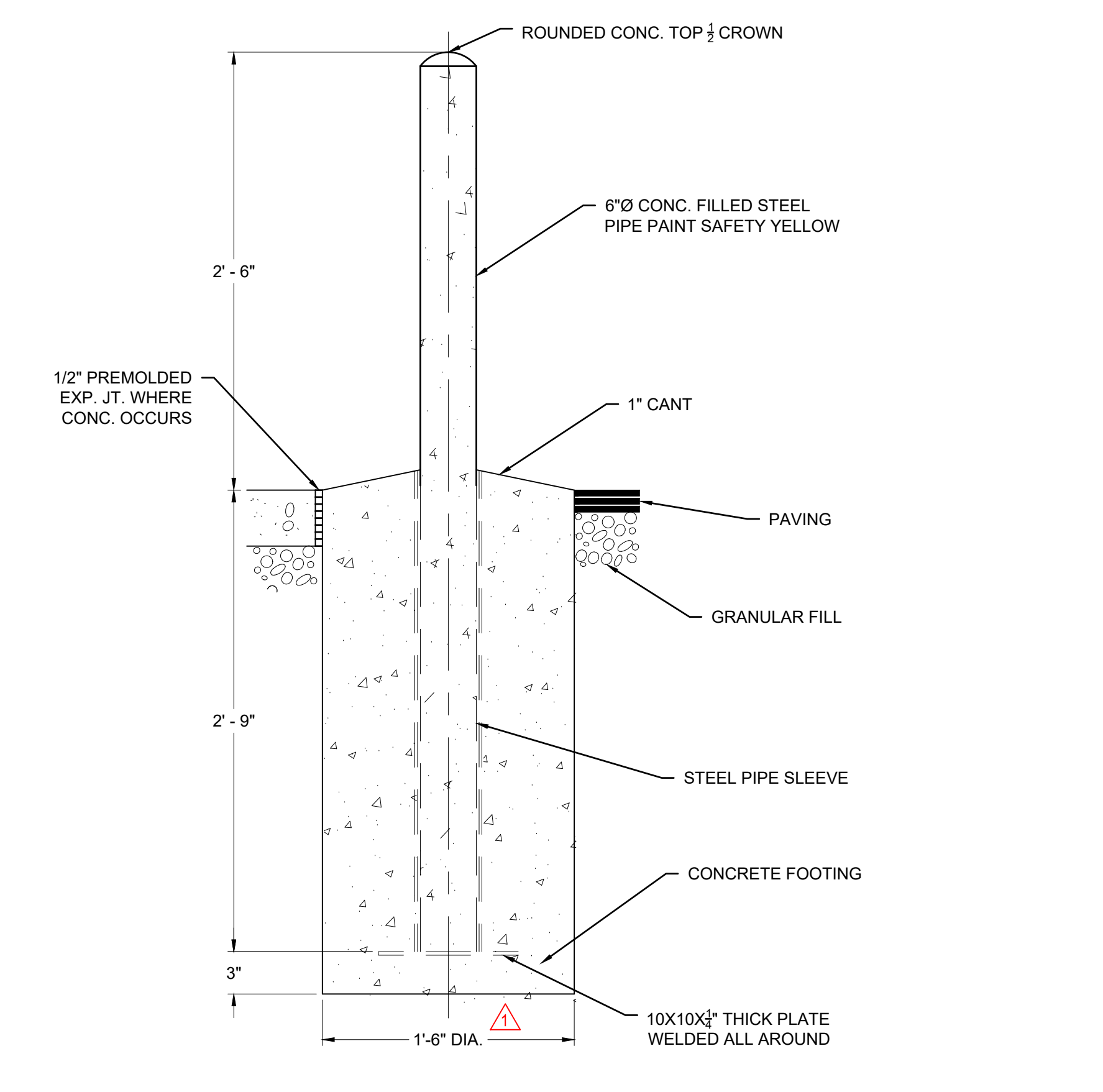

- NOTES:
- CONTRACTOR SHALL UTILIZE GALVANIZED COATED OR FULLY PAINT STEEL PIPE WITH AN EXTERIOR RUST INHIBITIVE PAINT PRIOR TO INSTALLATION AND TOUCH UP AFTER INSTALLATION SUCH AS SHERWIN-WILLIAMS MACROPROXY 646 FAST CURE (B58W610), IN ACCORDANCE WITH MANUFACTURER'S PREPARATION REQUIREMENTS. PROVIDE A YELLOW (BLUE FOR ADA) BOLLARD COVER APPROVED IN SPECIFICATION 055000 - METAL FABRICATIONS.
 - BOLLARD PROTECTION MAY NOT BE REQUIRED AT ALL FACILITIES. DETAIL IS DEPENDENT ON SITE CONDITIONS AND FINAL LAYOUT AT THE FACILITY.
 - INCREASE DEPTH OF EXTERIOR BOLLARDS AS REQUIRED BY LOCAL FROSTLINE.

4 TYP. SITE PIPE BOLLARD
NTS

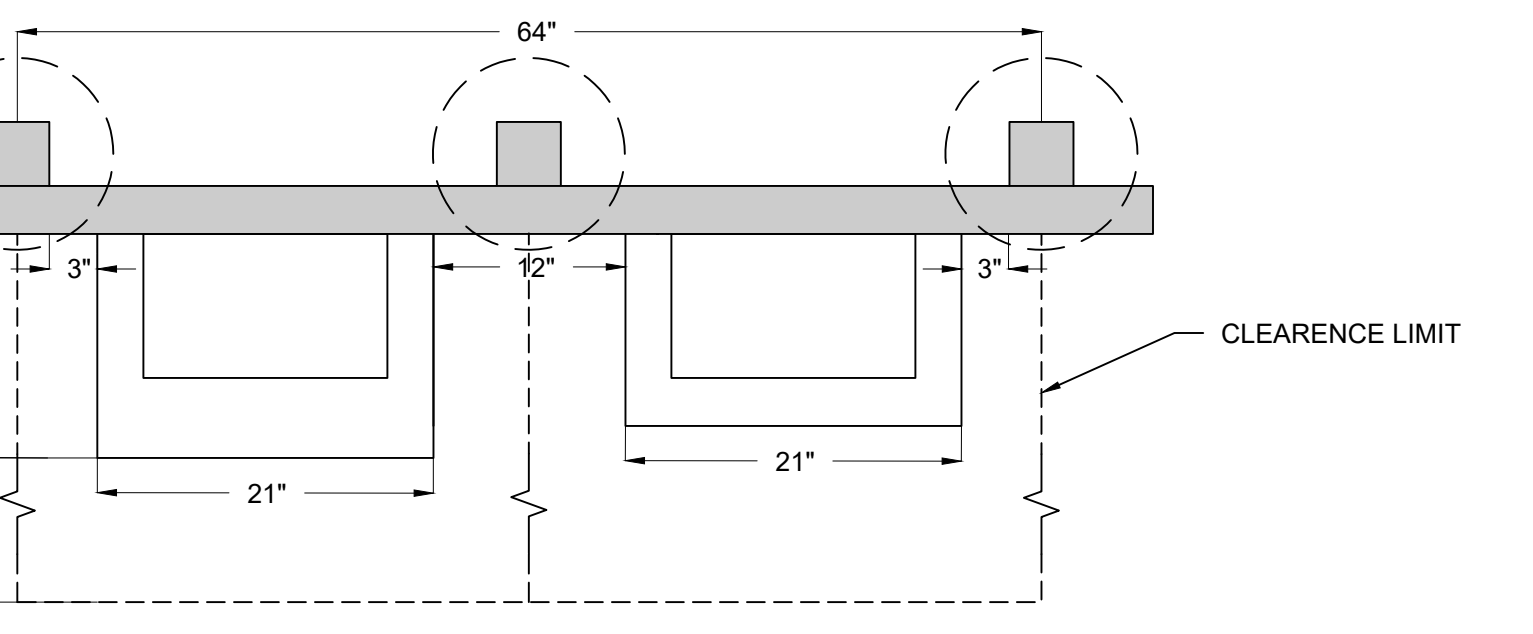
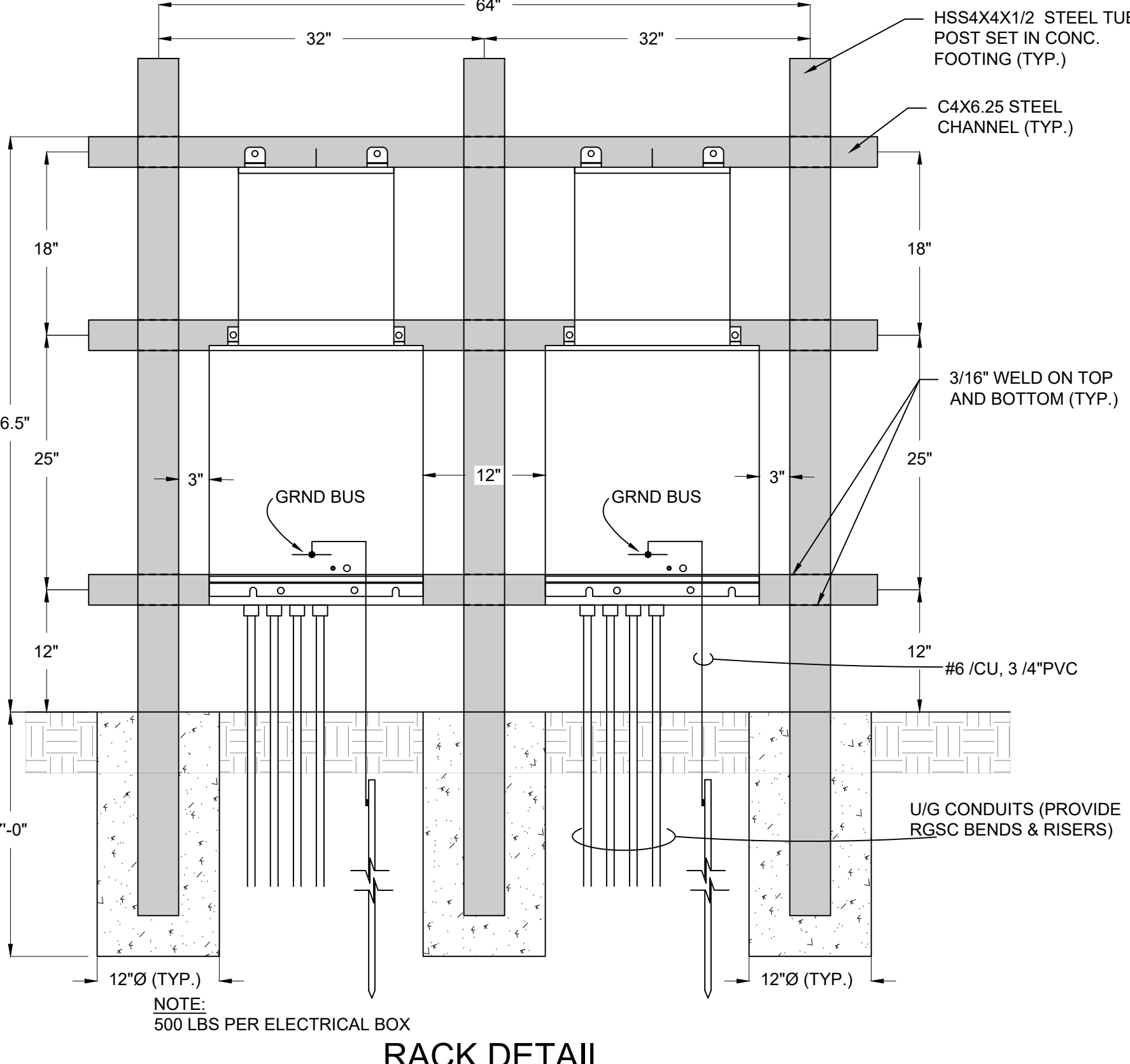

11 ELECTRICAL EQUIPMENT SUPPORT
NTS

SIGNAGE, AS REQ'D LOCATE SIGN AWAY FROM CURB AND NOT OBSTRUCTING THE ACCESSIBLE ROUTE (SEE DETAIL 13)

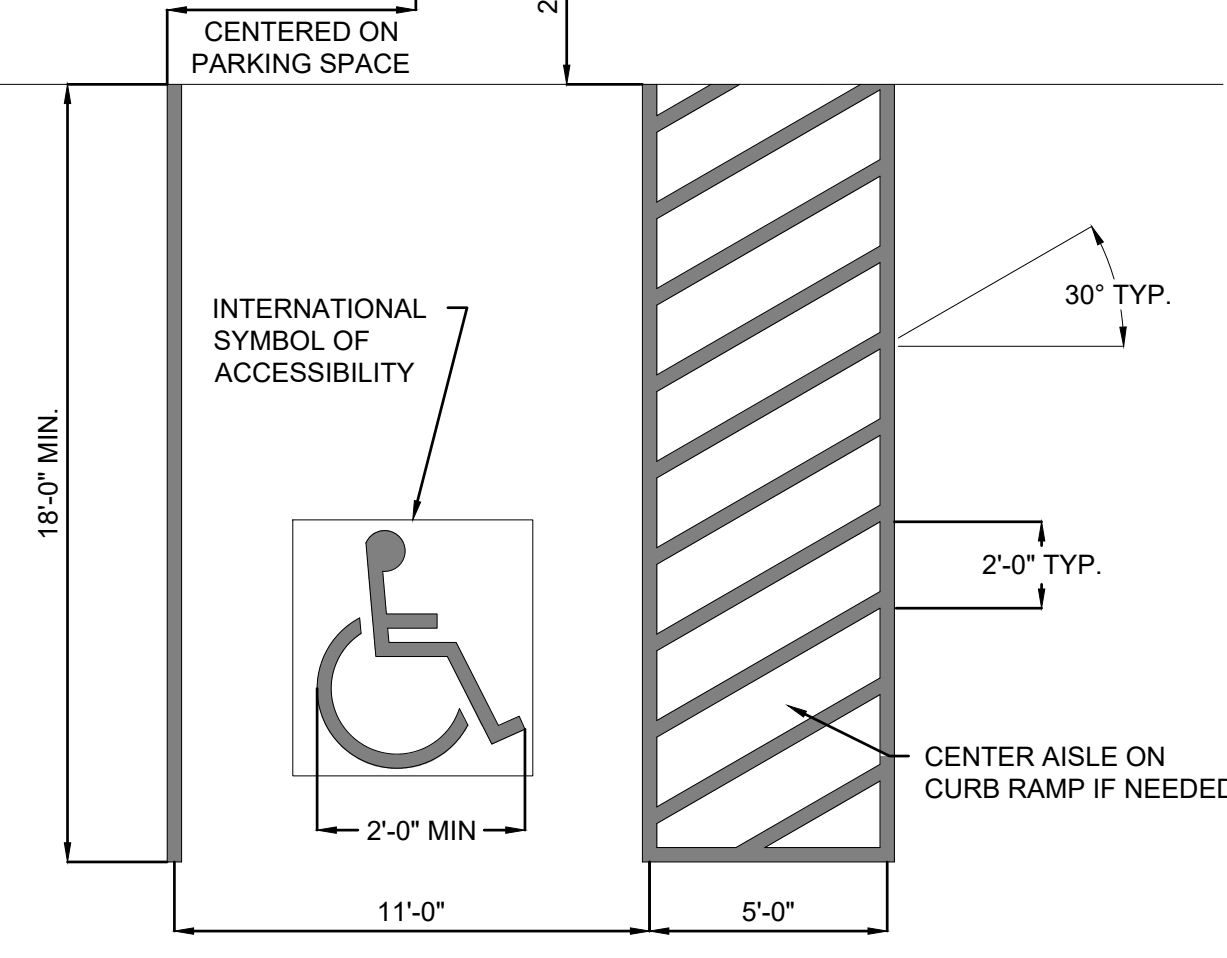

12 PAVEMENT MARKINGS - ACCESSIBLE PARKING SPACE AND AISLE
NTS

ACCESSIBLE PARKING SIGN(S) PER LOCAL CODE FASTENED WITH NON-CORROSIVE 3/8" MACHINE BOLTS W/ WASHERS, 2 PER SIGN MIN.
1.66" O.D., 14 GA. METAL SIGN W/ PLASTIC CAP POST EMBEDDED IN BOLLARD CONCRETE. PAINT POST POSTAL BLUE.

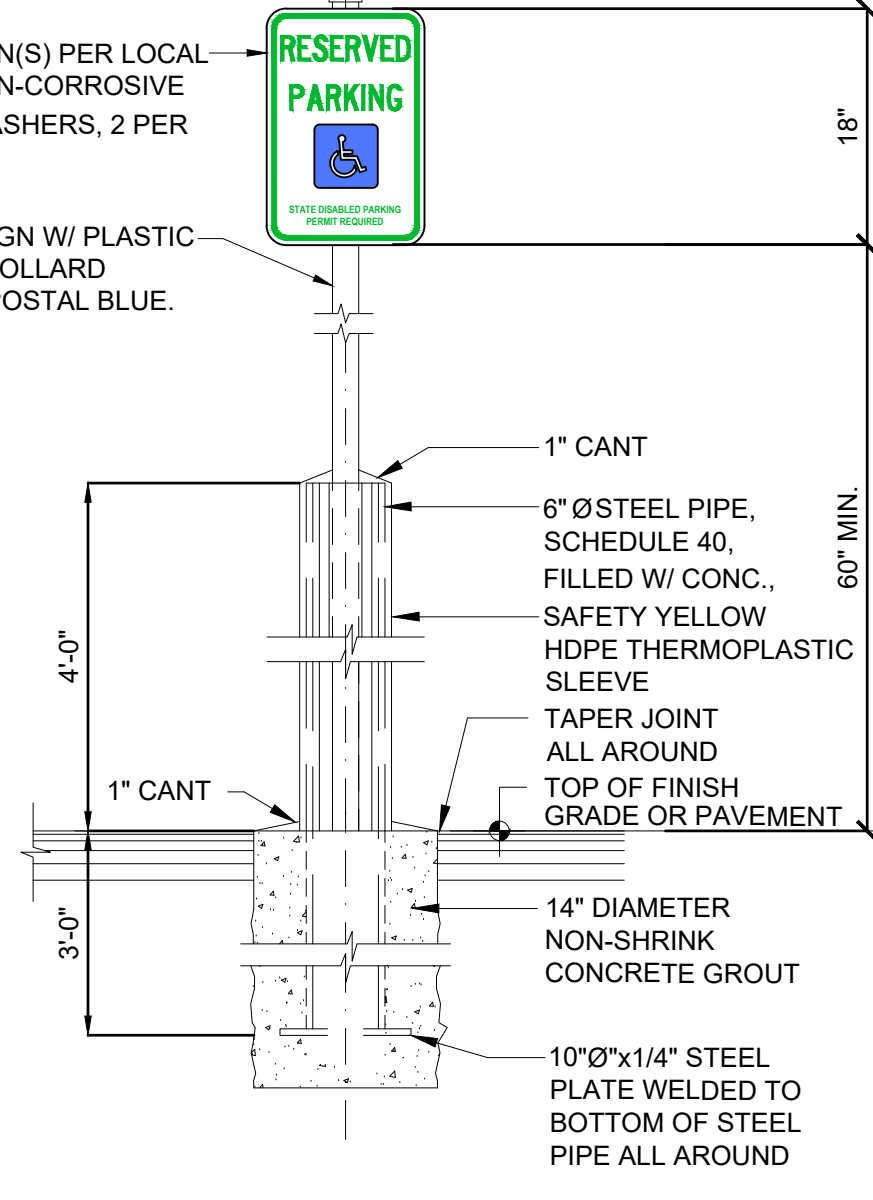

13 ACCESSIBLE PARKING SIGN/BOLLARD
NTS

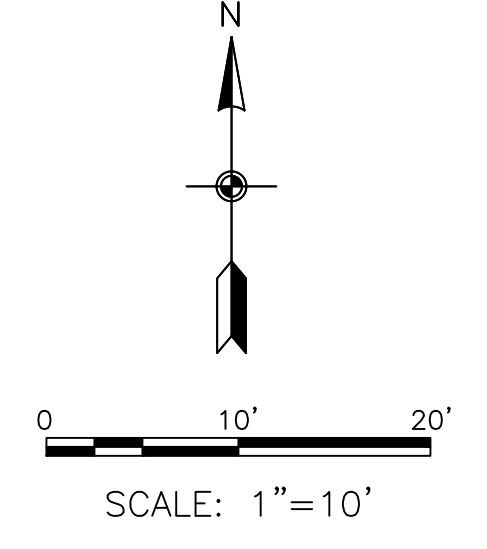
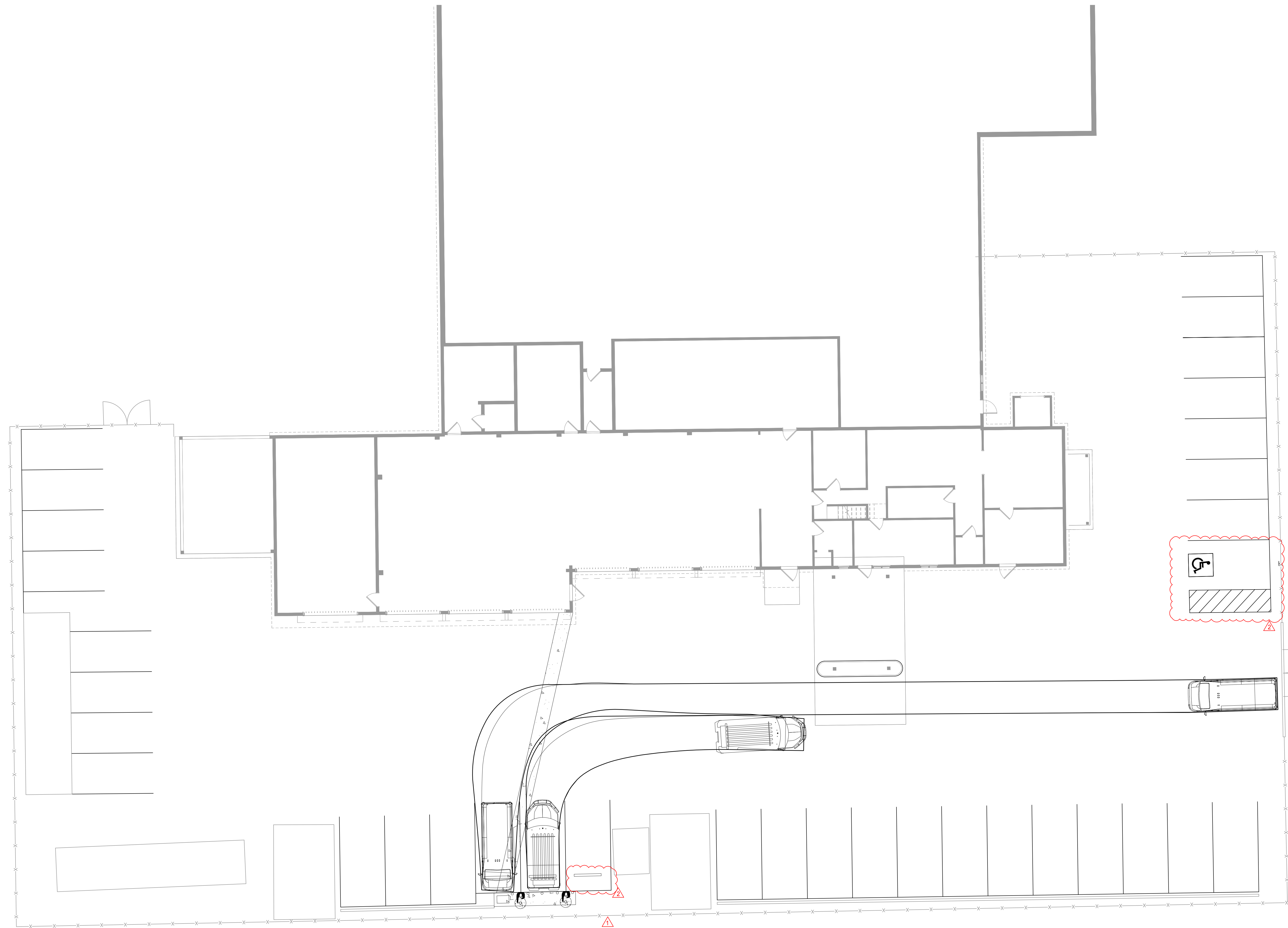

LEGEND

- EXISTING GRASS AREA
- EXISTING BUILDING
- EXISTING PAINT STRIPING
- EXISTING FENCE
- EXISTING GATE
- PROPOSED PAINT STRIPING
- PROPOSED PAVEMENT RESTORATION
- PROPOSED ACCESSIBLE PARKING
- NGDV PATH
- COTS PATH

NOTES:

1. NO TITLE SEARCH OR PROPERTY BOUNDARY SURVEY WAS COMPLETED FOR THIS PROJECT. NO BOUNDARY LINES ARE DEPICTED ON THIS DATABASE.
2. A SUBSURFACE UTILITY INVESTIGATION HAS NOT BEEN PERFORMED BY WSP. WA 811 SHOULD BE CONTACTED PRIOR TO COMMENCING ANY EXCAVATION. (800-424-5555). STORM AND SEWER CONNECTIONS WERE EXCLUDED FROM THIS SCOPE OF SERVICE AND ARE NOT SHOWN HEREON.
3. COORDINATES SHOWN BASED ON PUBLICLY AVAILABLE DATA. CONTRACTOR TO ESTABLISH BEARINGS AND COORDINATES SHOWN HEREON. IF ANY, ARE BASED ON THE WASHINGTON STATE PLANE COORDINATE SYSTEM, SOUTH ZONE, NORTH AMERICAN DATUM OF 1983.
4. ELEVATIONS SHOWN HEREON ARE BASED ON THE NORTH AMERICAN VERTICAL DATUM OF 1988 (NAVD 88) (GEOID 12B).
5. NOT FOR CONSTRUCTION. FOR TRAFFIC FLOW SUPPORT ONLY.

VEHICLE PROFILE

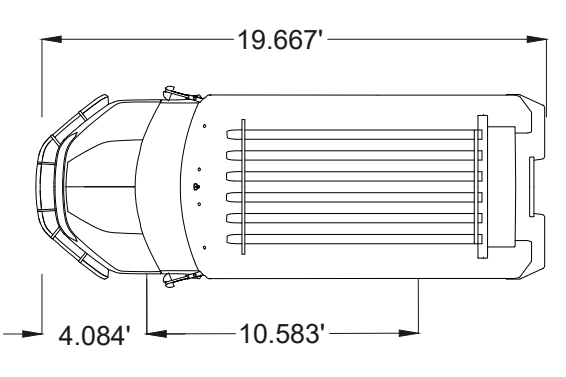

NGDV

OVERALL LENGTH	19.667 FT
OVERALL WIDTH	7.083 FT
OVERALL BODY HEIGHT	8.633 FT
CURB TO CURB TURNING RADIUS	22.000 FT

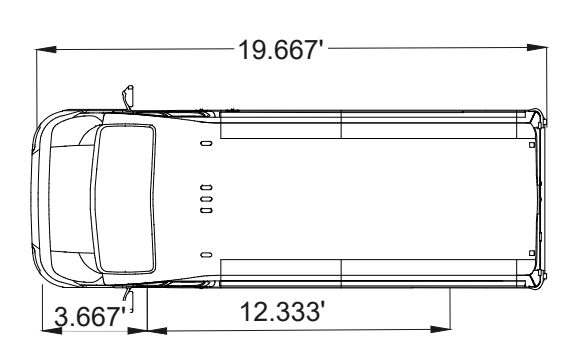

COTS

OVERALL LENGTH	19.667 FT
OVERALL WIDTH	6.833 FT
OVERALL BODY HEIGHT	8.500 FT
CURB TO CURB TURNING RADIUS	20.000 FT

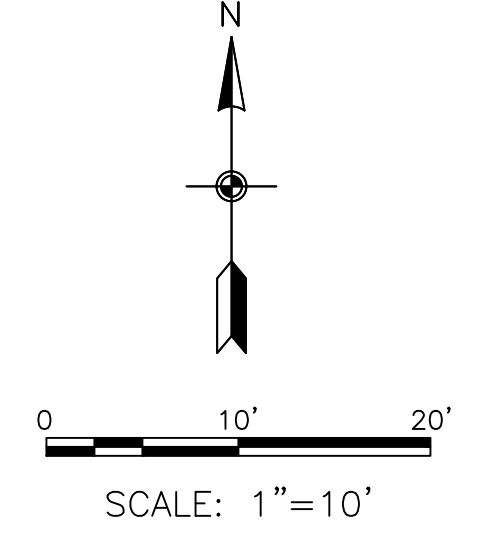
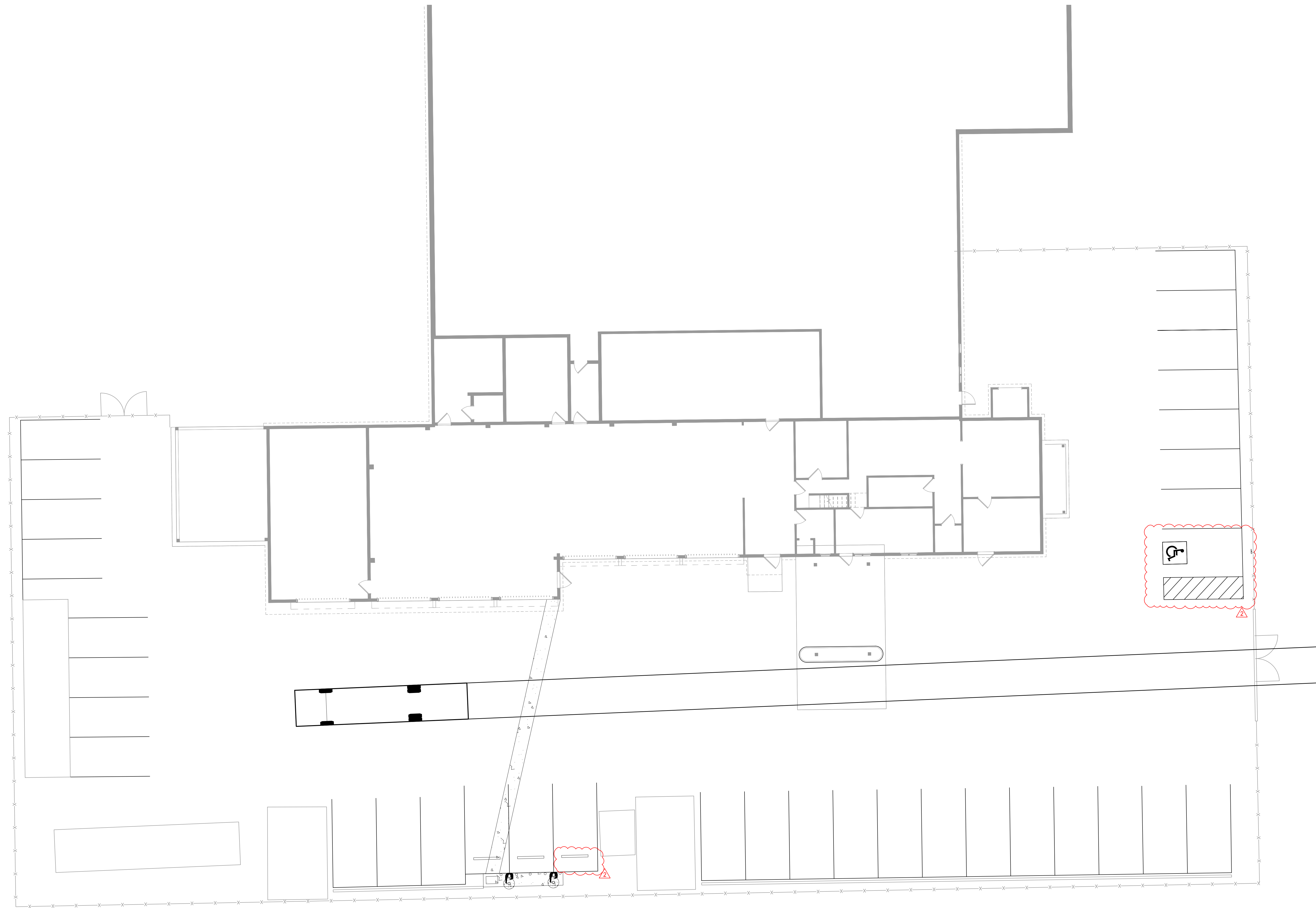

LEGEND

- EXISTING GRASS AREA
- EXISTING BUILDING
- EXISTING PAINT STRIPING
- EXISTING FENCE
- EXISTING GATE
- PROPOSED PAINT STRIPING
- PROPOSED PAVEMENT RESTORATION
- PROPOSED ACCESSIBLE PARKING
- FIRE TRUCK PATH

NOTES:

1. NO TITLE SEARCH OR PROPERTY BOUNDARY SURVEY WAS COMPLETED FOR THIS PROJECT. NO BOUNDARY LINES ARE DEPICTED ON THIS DATABASE.
2. A SUBSURFACE UTILITY INVESTIGATION HAS NOT BEEN PERFORMED BY WSP. WA 811 SHOULD BE CONTACTED PRIOR TO COMMENCING ANY EXCAVATION. (800-424-5555). STORM AND SEWER CONNECTIONS WERE EXCLUDED FROM THIS SCOPE OF SERVICE AND ARE NOT SHOWN HEREON.
3. COORDINATES SHOWN BASED ON PUBLICLY AVAILABLE DATA. CONTRACTOR TO ESTABLISH BEARINGS AND COORDINATES SHOWN HEREON, IF ANY, ARE BASED ON THE WASHINGTON STATE PLANE COORDINATE SYSTEM, SOUTH ZONE, NORTH AMERICAN DATUM OF 1983.
4. ELEVATIONS SHOWN HEREON ARE BASED ON THE NORTH AMERICAN VERTICAL DATUM OF 1988 (NAVD 88) (GEOID 12B).
5. NOT FOR CONSTRUCTION. FOR TRAFFIC FLOW SUPPORT ONLY.

VEHICLE PROFILE

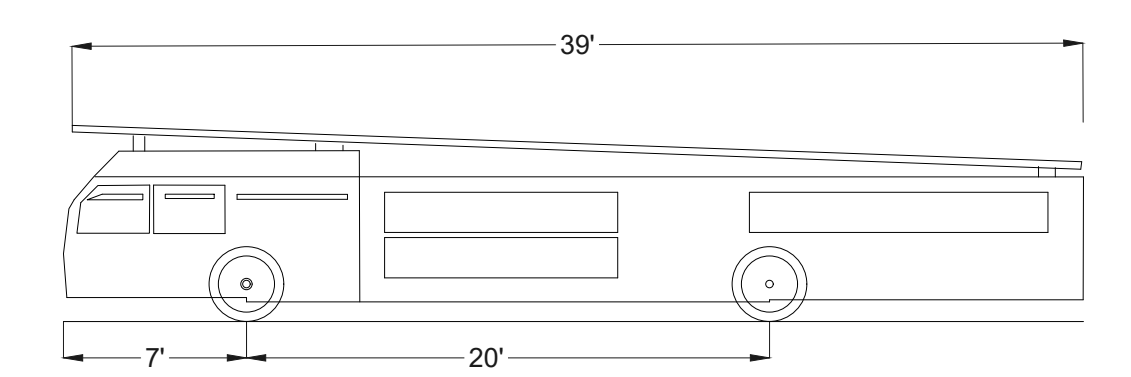

AERIAL FIRE TRUCK

OVERALL LENGTH	39.000 FT
OVERALL WIDTH	8.167 FT
OVERALL BODY HEIGHT	7.500 FT
MINIMUM BODY GROUND CLEARANCE	0.750 FT
TRACK WIDTH	8.167 FT
LOCK-TO-LOAD TIME	5.00 S
MAXIMUM WHEEL ANGLE	45.00°

ABBREVIATIONS

Table of abbreviations for construction terms, including A.C.T. (Acoustic Ceiling Tile), B.F.F. (Below Finish Floor), and C.B. (Catch Basin).

ARCHITECTURAL GRAPHIC SYMBOLS

Diagram showing architectural symbols for room names, view names, match lines, partition types, lift tags, furniture, glazed openings, and floor material references.

MATERIALS LEGEND

Diagram showing material symbols for earth, concrete, sand, brick, insulation, gravel, rough lumber, and wood blocking.

GENERAL NOTES

- List of 27 general notes detailing construction requirements, including existing conditions, dimensions, finishes, and safety protocols.

SHEET INDEX table with columns for SHEET NUMBER and SHEET NAME.

GENERAL table listing sheet numbers and names for general information and details.

ARCHITECTURAL table listing sheet numbers and names for architectural plans and details.

ELECTRICAL table listing sheet numbers and names for electrical general information and details.

DATE & TIME: 5/6/2024 1:02:41 PM

Vertical sidebar containing logos for KORTE, WSP, and UNITED STATES POSTAL SERVICE, along with project information and contact details.

DATE & TIME: 5/8/2024 1:02:34 PM

ROOM FINISH SCHEDULE- 1ST FLOOR														
NO.	ROOM NAME	FLOOR MATERIAL	FLOOR FINISH	WALLS								CEILING		REMARKS
				NORTH		EAST		SOUTH		WEST		MATERIAL	FINISH	
101	SERVICE BAY	CONC.	EPOXY	EXIST. CONC.	P - 1	EXIST. CONC./CMU	P - 1	EXIST. CONC.	P - 1	EXIST. CONC.	P - 1	EXIST.	EXIST. TO REMAIN	1
102	WASH BAY	CONC.	EPOXY	EXIST. CMU	P - 1	EXIST. CONC./CMU	P - 1	EXIST. CONC.	P - 1	EXIST. CONC.	P - 1	EXIST.	EXIST. TO REMAIN	1

LIFT SCHEDULE							
SERVICE BAY NUMBER	EXISTING LIFT			NEW LIFT			REMARKS
	LIFT TYPES	CAPACITY LB	LIFT NUMBER	LIFT TYPES	CAPACITY LB	LIFT NUMBER	

ROOM FINISH GENERAL NOTES

- REFER TO SPECIFICATIONS FOR ADDITIONAL INFORMATION.

ROOM FINISH SCHEDULE REMARKS

- PRESSURE CLEAN/GRIND EXISTING FLOOR AND WALL SURFACE. PATCH & REPAIR CHIPPED & CRACKED SURFACE. PREP FLOOR TO RECEIVE FLOOR FINISH AS REQUIRED PER MANUFACTURER.

DOOR SCHEDULE REMARKS

- CONTRACTOR TO FIELD VERIFY EXISTING OPENING DIMENSIONS.
- REFER TO SPECIFICATION FOR ADDITIONAL INFORMATION.
- CONTRACTOR TO FIELD VERIFY SURROUNDING AREAS OF DOOR OPENING, RETROFIT/RELOCATE EXISTING UTILITIES/DEVICE ASSEMBLIES AS REQUIRED FOR PROPER INSTALLATION & OPERATION OF NEW DOOR.
- PAINT BOTH SIDES AND EDGES OF ALL EXISTING HOLLOW METAL DOORS WITH P-6 PER USPS STANDARDS.

LIFT SCHEDULE REMARKS

- REFER TO SPECIFICATION FOR LIFT MODEL INFORMATION.
- REFER TO SHEET A500 FOR LIFT DETAILS.

REFINISHED DOOR SCHEDULE										
NO.	DOOR		FRAME		REMARKS					
	MATERIAL	FINISH	MATERIAL	FINISH						
101	EXIST.	P - 6	EXIST.	P - 6	1, 2, 3, & 4					
102	EXIST.	P - 6	EXIST.	P - 6	1, 2, 3, & 4					
103	EXIST.	P - 6	EXIST.	P - 6	1, 2, 3, & 4					
104	EXIST.	P - 6	EXIST.	P - 6	1, 2, 3, & 4					
105	EXIST.	P - 6	EXIST.	P - 6	1, 2, 3, & 4					
106	EXIST.	P - 6	EXIST.	P - 6	1, 2, 3, & 4					
107	EXIST.	P - 6	EXIST.	P - 6	1, 2, 3, & 4					
108	EXIST.	P - 6	EXIST.	P - 6	1, 2, 3, & 4					
109	EXIST.	P - 6	EXIST.	P - 6	1, 2, 3, & 4					
110	EXIST.	P - 6	EXIST.	P - 6	1, 2, 3, & 4					
111	EXIST.	P - 6	EXIST.	P - 6	1, 2, 3, & 4					

NEW OVERHEAD DOOR SCHEDULE										
NO.	SIZE			TYPE	DOOR		FRAME		REMARKS	
	WIDTH	HEIGHT	THICKNESS		MATERIAL	FINISH	MATERIAL	FINISH		
N101	12' - 0"	12' - 0"	3/4"	COILING	STL.	FACTORY POWDER COAT TO MATCH EXIST.	STL.	FACTORY POWDER COAT TO MATCH EXIST.	1, 2, & 3	
N102	12' - 0"	12' - 0"	3/4"	COILING	STL.	FACTORY POWDER COAT TO MATCH EXIST.	STL.	FACTORY POWDER COAT TO MATCH EXIST.	1, 2, & 3	
N103	12' - 0"	12' - 0"	3/4"	COILING	STL.	FACTORY POWDER COAT TO MATCH EXIST.	STL.	FACTORY POWDER COAT TO MATCH EXIST.	1, 2, & 3	
N104	12' - 0"	14' - 0"	3/4"	COILING	STL.	FACTORY POWDER COAT TO MATCH EXIST.	STL.	FACTORY POWDER COAT TO MATCH EXIST.	1, 2, & 3	
N105	12' - 0"	14' - 0"	3/4"	COILING	STL.	FACTORY POWDER COAT TO MATCH EXIST.	STL.	FACTORY POWDER COAT TO MATCH EXIST.	1, 2, & 3	
N106	12' - 0"	14' - 0"	3/4"	COILING	STL.	FACTORY POWDER COAT TO MATCH EXIST.	STL.	FACTORY POWDER COAT TO MATCH EXIST.	1, 2, & 3	
N107	12' - 0"	14' - 0"	3/4"	COILING	STL.	FACTORY POWDER COAT TO MATCH EXIST.	STL.	FACTORY POWDER COAT TO MATCH EXIST.	1, 2, & 3	

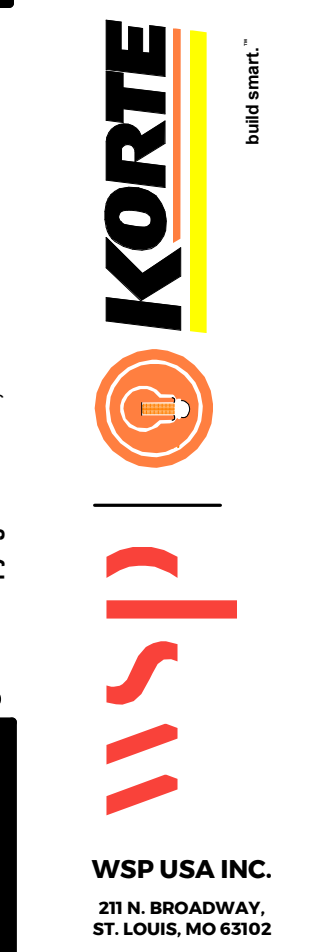

WSP USA INC.
20 N. BROADWAY
ST. LOUIS, MO 63102

TACOMA
3825 S WARNER ST
TACOMA, WA 98409



90% DESIGN SUBMITTAL
SCHEDULES
Scale: AS NOTED
Date: Jun 26, 2024
Project: TACOMA
USPS File Number: E10234
Revisions:
2, Revision 2
05/02/2024

DEMO GENERAL NOTES

ITEMS BELOW APPLY TO DASHED LINES AS INDICATED ON THE DEMOLITION PLAN UNLESS OTHERWISE NOTED.

- THE BUILDING AREAS ADJACENT TO THE AREA OF CONSTRUCTION WILL REMAIN OCCUPIED THROUGHOUT CONSTRUCTION. THE CONTRACTOR SHALL TAKE EVERY PRECAUTION FOR THE SAFETY AND PROTECTION OF ALL PERSONS IN THE BUILDING UNDER CONSTRUCTION FOR THE DURATION OF THE PROJECT.
- EXISTING CONDITIONS ARE BASED ON INFORMATION OBTAINED FROM EXISTING DRAWINGS AND FIELD SURVEY AND SHALL NOT BE CONSTRUED AS "AS-BUILT." THE CONTRACTOR SHALL FIELD VERIFY ALL EXISTING CONDITIONS PRIOR TO CONSTRUCTION.
- IN THE EVENT THAT QUESTIONABLE ENVIRONMENTAL MATERIALS ARE SUSPECTED OR IDENTIFIED BY THE CONTRACTOR, THE OWNER'S REPRESENTATIVE SHALL BE NOTIFIED IMMEDIATELY TO DETERMINE THE EXTENT OF MATERIAL AND THE COURSE OF ACTION.
- ALL MECHANICAL, ELECTRICAL, PLUMBING, AND FIRE PROTECTION ELEMENTS WITHIN THE AREA OF DEMOLITION THAT ARE TO BE REMOVED, SHALL BE CUT AND CAPPED AND MADE SAFE BY A SUBCONTRACTOR TRADESMAN APPROPRIATE TO THE SCOPE PRIOR TO DEMOLITION AND REMOVAL WORK OCCURRING BY THE DEMOLITION SUBCONTRACTOR.
- ALL DASHED PARTITIONS, WALL FURRING, SURFACE APPLIED MATERIALS OR FINISHES (I.E. WALL COVERINGS, WOOD PANELING, ETC.) PIPE AND CHASE FURRING IN INTERIOR SPACES AND AT PERIMETER WALLS SHALL BE REMOVED FULL HEIGHT INCLUDING DOORS AND FRAMES, ETC. WITHIN THE PARTITIONS.
- REQUIREMENTS OF STRUCTURAL WORK: DO NOT CUT STRUCTURAL WORK IN A MANNER RESULTING IN A REDUCTION OF LOAD-CARRYING CAPACITY OF LOAD/DEFLECTION RATIO.
- OPERATIONAL AND SAFETY LIMITATIONS: DO NOT CUT OPERATIONAL ELEMENTS AND SAFETY-RELATED COMPONENTS IN A MANNER RESULTING IN A REDUCTION OF CAPACITIES TO PERFORM IN A MANNER INTENDED OR RESULTING IN A DECREASED OPERATIONAL LIFE, INCREASED MAINTENANCE, OR DECREASED SAFETY.
- VISUAL REQUIREMENTS: DO NOT CUT WORK WHICH IS EXPOSED ON THE EXTERIOR OR EXPOSED IN OCCUPIED SPACES OF THE BUILDING IN A MANNER RESULTING IN A REDUCTION OF VISUAL QUALITIES OR RESULTING IN SUBSTANTIAL EVIDENCE OF THE DEMOLITION WORK JUDGED BY THE ARCHITECT TO BE CUT AND PATCHED IN A VISUALLY UNSATISFACTORY MANNER.
- LOADING: DO NOT SUPERIMPOSE LOADS AT ANY POINT UPON EXISTING STRUCTURE BEYOND DESIGN CAPACITY INCLUDING LOADS ATTRIBUTABLE TO MATERIALS, CONSTRUCTION EQUIPMENT, DEMOLITION OPERATIONS AND SHORING AND BRACING.
- VIBRATION: DO NOT USE MEANS, METHODS, TECHNIQUES, OR PROCEDURES WHICH WOULD INDUCE VIBRATION INTO ANY ELEMENT OF THE STRUCTURE.
- FIRE: DO NOT USE MEANS, METHODS, TECHNIQUES, OR PROCEDURES WHICH WOULD PRODUCE ANY FIRE HAZARD UNLESS OTHERWISE APPROVED BY CONTRACTING OFFICER.
- WATER: DO NOT USE MEANS, METHODS, TECHNIQUES, OR PROCEDURES WHICH WOULD PRODUCE EXCESSIVE WATER RUN-OFF, AND WATER POLLUTION.
- AIR POLLUTION: DO NOT USE MEANS, METHODS, TECHNIQUES, OR PROCEDURES WHICH WOULD PRODUCE UNCONTROLLED DUST, FUMES, OR OTHER DAMAGING AIR POLLUTION.

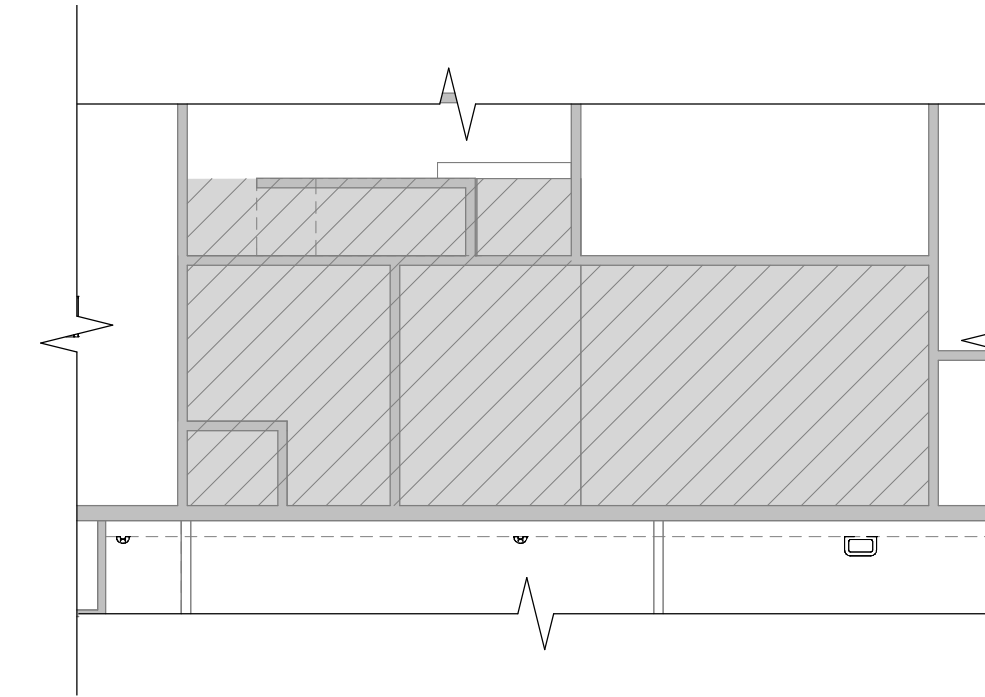

2 OVERALL MEZZANINE DEMOLITION REFLECTED CEILING PLAN

AD150 SCALE: 1/8" = 1'-0"

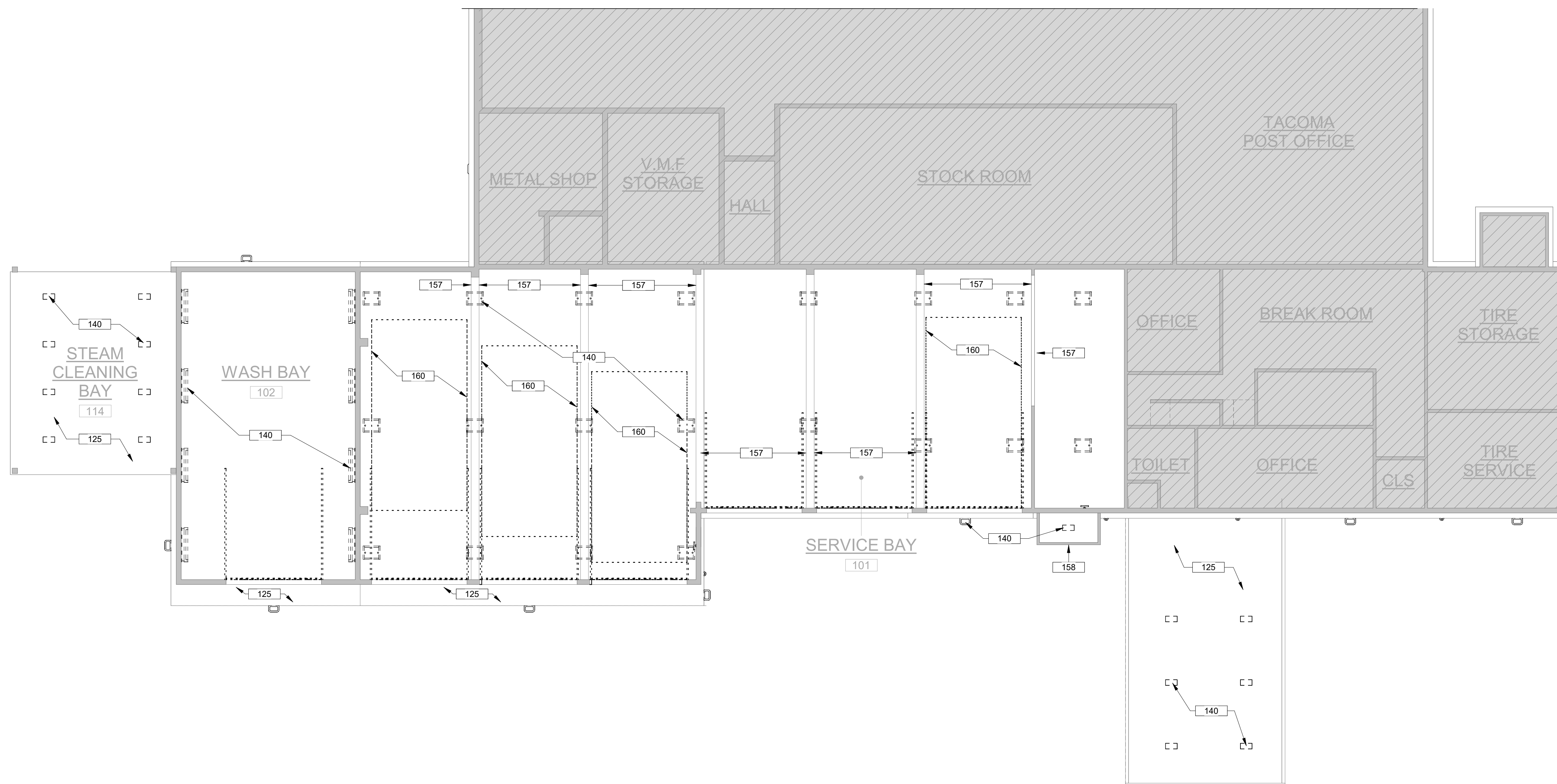

KEYNOTES LEGEND - DEMO

MARK	DESCRIPTION
125	PRESSURE WASH/CLEAN EXISTING CANOPY STRUCTURE; PATCH/REPAIR SURFACE AS REQUIRED.
140	EXISTING LIGHT FIXTURES/ELECTRICAL EQUIPMENT AND ALL RELATED HARDWARE TO BE REMOVED. CONTRACTOR TO VERIFY EXISTING FIXTURE QUANTITY. REFER TO ELECTRICAL DRAWINGS FOR ADDITIONAL INFORMATION.
157	PREPARE EXISTING BEAM TO RECEIVE NEW FINISH; CLEAN, PREP AND PATCH/REPAIR AS REQUIRED; TYP.
158	PRESSURE WASH/CLEAN EXISTING AWNING.
160	ALL UTILITIES, FIXTURES, MECHANICAL SYSTEMS OR ANY OBSTRUCTIONS WITHIN LIFT SERVICE AREAS SHALL BE RELOCATED ABOVE 16' - 3" A.F.F.

LEGEND

NOT IN SCOPE

INDICATES ELEMENTS TO BE DEMO'D.
SEE KEYNOTES FOR DETAILS

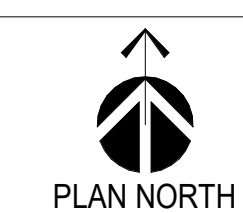

0' 4' 8' 16'
1/8" = 1'-0"

1 OVERALL FIRST FLOOR DEMOLITION REFLECTED CEILING PLAN

AD150 SCALE: 1/8" = 1'-0"

DATE & TIME: 5/8/2024 1:02:40 PM

GENERAL NOTES

REFER TO G.002 FOR GENERAL NOTES

KEYNOTES LEGEND	
MARK	DESCRIPTION
225	PRESSURE WASH/CLEAN EXISTING CANOPY STRUCTURE; PATCH/REPAIR SURFACE AS REQUIRED.
240	NEW LIGHT FIXTURE ASSEMBLY/ELECTRICAL EQUIPMENT; TYP. REFER TO ELECTRICAL DRAWINGS FOR ADDITIONAL INFORMATION.
257	PAINT EXISTING BEAM UNTIL CEILING; CLEAN, PREP AND PRIME AS REQUIRED FOR NEW FINISH; COLOR TO BE P-1; TYP.
258	PRESSURE WASH/CLEAN EXISTING AWNING.
260	ALL UTILITIES, FIXTURES, MECHANICAL SYSTEMS OR ANY OBSTRUCTIONS WITHIN LIFT SERVICE AREAS SHALL BE RELOCATED ABOVE 16'-3" A.F.F.

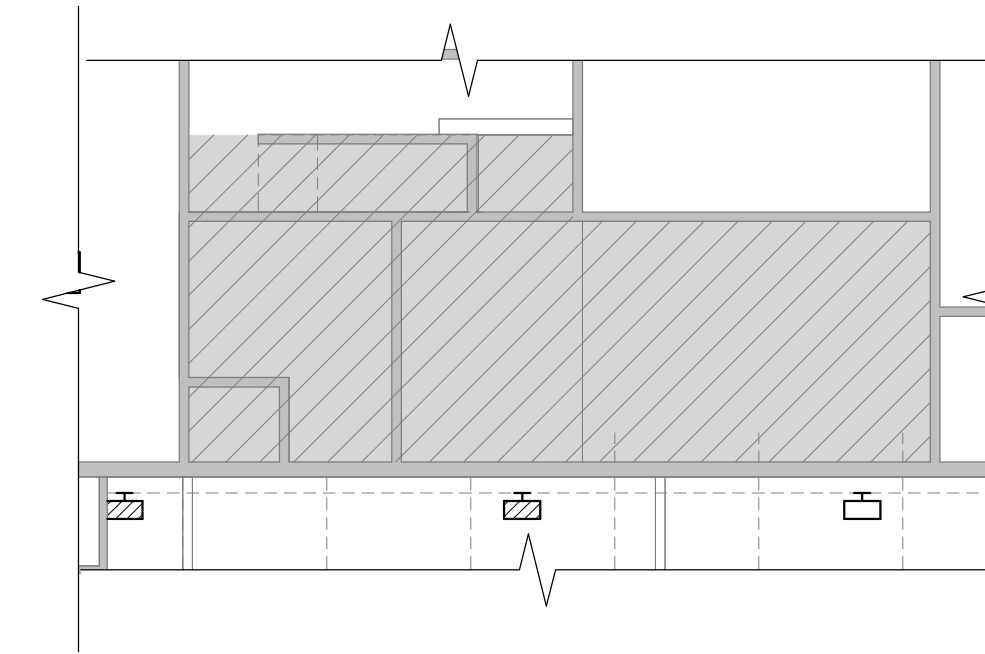

2 OVERALL PROPOSED MEZZANINE REFLECTED CEILING PLAN

A150 SCALE: 1/8" = 1'-0"

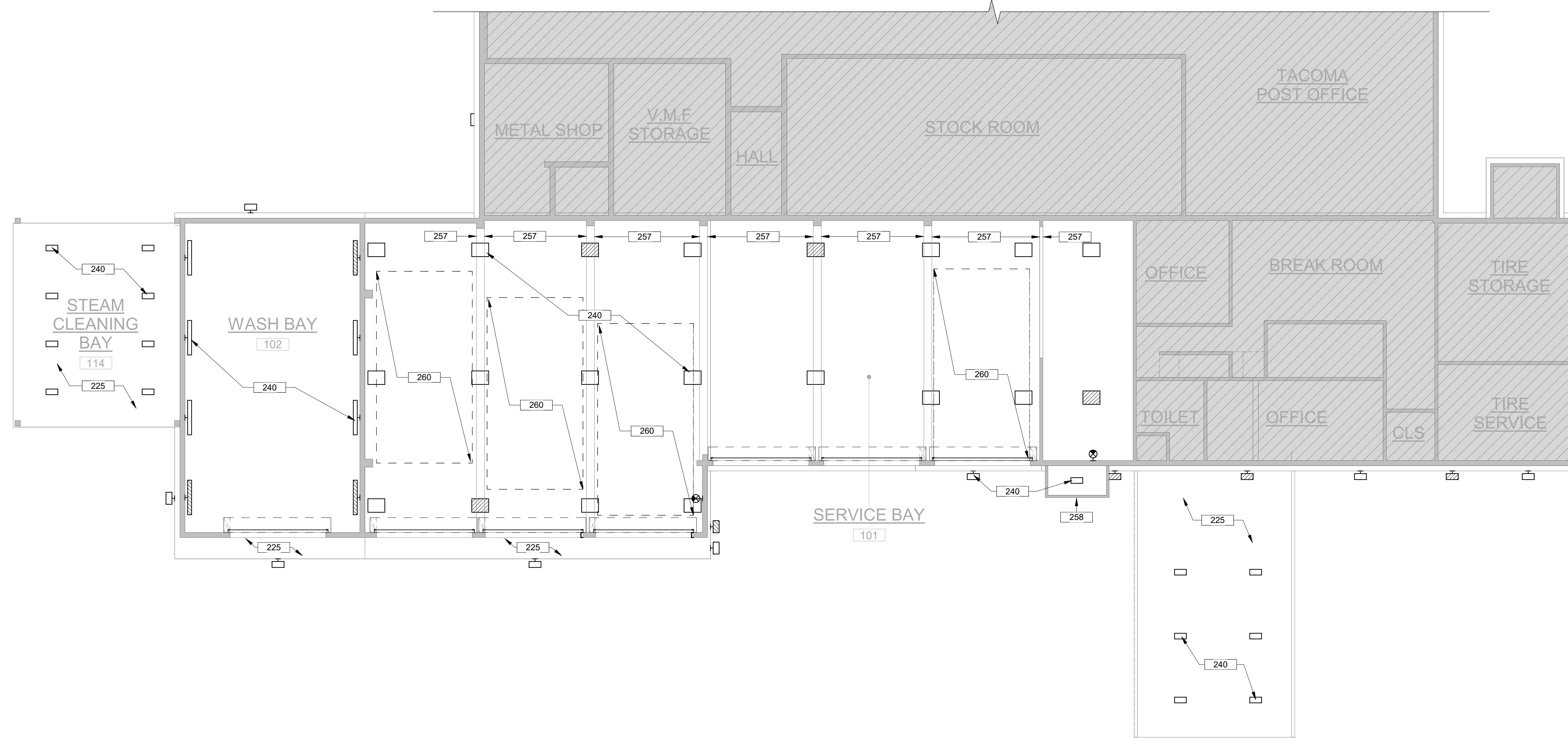

1 OVERALL PROPOSED FIRST FLOOR REFLECTED CEILING PLAN

A150 SCALE: 1/8" = 1'-0"

LEGEND
 NOT IN SCOPE

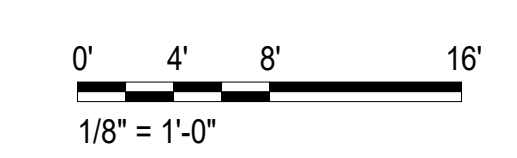
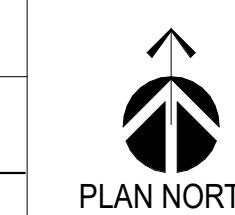

A150
 Scale: AS NOTED
 Project: TACOMA
 USPS File Number: E10234

OVERALL PROPOSED FIRST FLOOR & MEZZANINE REFLECTED CEILING PLAN
 Date: Jan 26, 2024
 Revisions:
 2, Revision 2
 06/03/2024

UNITED STATES POSTAL SERVICE

TACOMA
 3825 S WARNER ST
 TACOMA, WA 98409

KORTE
 WSP
 WSP USA INC.
 201 N. BROADWAY
 ST. LOUIS, MO 63102

DATE & TIME: 5/6/2024 1:02:35 PM

A. SUPPLEMENTAL GENERAL CONDITIONS

- 1. THE DRAWINGS ARE GENERALLY DIAGRAMMATIC AND IT IS THE INTENT AND MEANING OF THE CONTRACT DOCUMENTS THAT THE CONTRACTOR SHALL PROVIDE AN ELECTRICAL INSTALLATION THAT IS COMPLETE WITH ALL ITEMS AND APPURTENANCES NECESSARY, REASONABLE INCIDENTAL, OR CUSTOMARILY INCLUDED, EVEN THOUGH EACH AND EVERY ITEM IS NOT SPECIFICALLY CALLED OUT OR SHOWN. THE CONTRACTOR SHALL PROVIDE ALL EQUIPMENT, MATERIALS, LABOR, SUPERVISION AND SERVICE NECESSARY SO AS TO PROVIDE A COMPLETE, FUNCTIONING ELECTRICAL SYSTEM IN SAFE WORKING ORDER.
2. SYMBOLS FOR VARIOUS ELEMENTS AND SYSTEMS ARE SHOWN ON THE DRAWINGS. SHOULD THERE BE ANY DOUBT REGARDING THE MEANING OR INTENT OF THE SYMBOLS USED, AN INTERPRETATION SHALL BE OBTAINED FROM THE ARCHITECT IN WRITING. THE DECISION OF THE ARCHITECT SHALL BE FINAL.
3. IT SHALL BE THE RESPONSIBILITY OF EACH CONTRACTOR TO EXAMINE THE CONTRACT DOCUMENTS CAREFULLY BEFORE SUBMITTING THEIR BID, WITH PARTICULAR ATTENTION TO ERRORS, OMISSIONS, CONFLICTS WITH PROVISIONS OF LAWS AND CODES HAVING JURISDICTION, CONFLICTS BETWEEN DRAWINGS OR DRAWINGS AND SPECIFICATIONS, AND AMBIGUOUS DEFINITION OF THE EXTENT OF COVERAGE BETWEEN CONTRACTS. ANY DISCREPANCY SHALL BE BROUGHT IMMEDIATELY TO THE ATTENTION OF THE ARCHITECT FOR CORRECTION. SHOULD ANY OF THESE ERRORS, OMISSIONS, CONFLICTS, OR AMBIGUITIES EXIST, THE CONTRACTOR SHALL HAVE THEM EXPLAINED AND ADJUSTED IN WRITING BEFORE SIGNING THE CONTRACT OR PROCEEDING WITH THE WORK. OTHERWISE, THE CONTRACTOR SHALL, AT THEIR OWN EXPENSE, SUPPORT THE PROPER MATERIALS AND LABOR TO MAKE GOOD ANY DAMAGE OR DEFECTS IN THEIR WORK OR THE RESULTS OBTAINED THEREFROM, CAUSED BY SUCH DISCREPANCY.
4. WHEREVER CONFLICTS OCCUR BETWEEN DIFFERENT PARTS OF THE CONTRACT DOCUMENTS, THE GREATER QUANTITY, THE BETTER QUALITY, OR LARGER SIZE SHALL PREVAIL UNLESS THE ARCHITECT INFORMS THE CONTRACTOR OTHERWISE IN WRITING.
5. THE SCALE OF EACH DRAWING IS RELATIVELY ACCURATE; ANY DIMENSIONS THAT ARE APPROPRIATE TO CENTERLINE FROM ASSUMED BUILDING PERIMETER, THE CONTRACTOR SHALL OBTAIN THE NECESSARY DIMENSIONS FOR ANY EXACT TAKEOFFS FROM THE ARCHITECT. NO ADDITIONAL COST TO THE OWNER WILL BE CONSIDERED FOR FAILURE TO OBTAIN EXACT DIMENSIONS WHERE NOT CLEAR OR IN ERROR ON THE DRAWINGS. ANY DEVICE OR FIXTURE ROUGHED IN IMPROPERLY AND NOT POSITIONED ON IMPLIED CENTERLINES OR AS REQUIRED BY GOOD PRACTICE MUST BE REPOSITIONED AT NO COST TO THE OWNER.
6. ONLY EXPERIENCED CRAFTSMEN KNOWLEDGEABLE IN THEIR RESPECTIVE TRADE SHALL PERFORM THE WORK DESCRIBED IN THE CONSTRUCTION DOCUMENTS.
7. ALL WORK SHALL BE DONE IN ACCORDANCE WITH THE LATEST ADOPTED EDITION OF NFPA STANDARD 70 (NATIONAL ELECTRICAL CODE). CONTRACTOR SHALL ALSO CONFORM TO ALL APPLICABLE LOCAL CODES AND AMENDMENTS.
8. UNLESS OTHERWISE INDICATED, ALL EQUIPMENT AND MATERIALS SHALL BE NEW AND SHALL MEET NEMA AND ANSI STANDARDS. THEY SHALL ALSO BE LISTED/LABELED BY A NATIONALLY RECOGNIZED LABORATORY IN ACCORDANCE WITH NFPA 70. EQUIPMENT AND MATERIALS SHALL BE INSTALLED IN ACCORDANCE WITH MANUFACTURER'S RECOMMENDATIONS, AND WITHIN THEIR LISTING/LABELING REQUIREMENTS AND RESTRICTIONS.
9. PROVIDE SHOP DRAWINGS FOR ENGINEER'S REVIEW FOR ALL ELECTRICAL EQUIPMENT, DEVICES, AND MATERIALS PROPOSED TO BE PROVIDED UNDER THIS CONTRACT. ANY DEVIATIONS FROM ITEMS SPECIFIED SHALL BE CLEARLY IDENTIFIED AND SEPARATELY SUBMITTED WITH A FORMAL SUBSTITUTION REQUEST. REFER TO SPECIFICATIONS (PROJECT MANUAL) FOR REQUIREMENTS.
10. PROVIDE MINIMUM 2-HOUR RATED FIRESTOPPING AT ALL ELECTRICAL PENETRATIONS THROUGH WALLS. REFER TO SPECIFICATION SECTION 078400 FIRESTOPPING. REFER TO 078400 SECTION 3.6 SCHEDULES FOR LIST OF ACCEPTABLE FIRESTOPPING ASSEMBLIES

B. ELECTRICAL EQUIPMENT

- 1. PROVIDE AN IDENTIFICATION NAMEPLATE FOR EACH ELECTRICAL EQUIPMENT SPECIFYING THE DESIGNATION INDICATED ON THE DRAWINGS. REFER TO SPECIFICATIONS FOR FURTHER REQUIREMENTS.
2. WEATHERPROOF ENCLOSURES SHALL BE PROVIDED FOR ALL ELECTRICAL EQUIPMENT, DEVICES AND APPURTENANCES (ALL SYSTEMS) INSTALLED OUTDOORS.
3. COORDINATE AND SCHEDULE ALL POWER OUTAGES WITH OWNER. REFER TO SPECIFICATIONS FOR FURTHER REQUIREMENTS.
4. SPACE ALLOCATIONS FOR MATERIALS, EQUIPMENT AND DEVICES HAVE BEEN MADE ON THE BASIS OF PRESENT AND KNOWN FUTURE REQUIREMENTS AND THE DIMENSIONS OF ITEMS OF EQUIPMENT OR DEVICES OF A PARTICULAR MANUFACTURER. THE CONTRACTOR SHALL VERIFY THAT ALL MATERIALS, EQUIPMENT AND DEVICES PROPOSED FOR USE ON THIS PROJECT ARE WITHIN THE CONSTRAINTS OF THE ALLOCATED SPACE.
5. DO NOT USE PERMANENT INK WHEN MAKING FIELD MARKINGS OR TEMPORARY CIRCUIT LABELS ON PANELS. CONTRACTOR SHALL USE REMOVABLE TAPE/TAGS FOR ALL TEMPORARY MARKINGS AND SHALL REMOVE THESE TEMPORARY MARKINGS AT THE CONCLUSION OF THIS PROJECT.
6. GENERAL ELECTRICAL EQUIPMENT AND DEVICES SHALL BE RATED AT MINIMUM 60°C.

C. SITE WORK

- 1. COORDINATE WITH THE SITE WORK FOR THE LOCATION, DIMENSIONS AND ELEVATION OF ALL DUCTBANKS/SERVICE CONDUITS EXTERNAL TO THE BUILDING PRIOR TO INSTALLATION OF ALL DUCTBANKS/SERVICE CONDUITS INTERNAL TO THE BUILDING.
2. COORDINATE ALL ELECTRICAL UTILITY SERVICE REQUIREMENTS WITH UTILITIES REPRESENTATIVE PRIOR TO COMMENCING ANY ELECTRICAL SITE WORK. CONTRACTOR SHALL SCHEDULE ALL NECESSARY MEETINGS BETWEEN UTILITY COMPANIES CONSTRUCTION FOREMAN, ELECTRICAL SUBCONTRACTORS, AND VARIOUS SUBCONTRACTORS RESPONSIBLE FOR SITE CONSTRUCTION PRIOR TO ELECTRICAL ROUGH-IN.
3. PENETRATIONS OF WALLS, FLOORS, AND ROOFS FOR THE PASSAGE OF ELECTRICAL RACEWAYS SHALL BE APPROVED BY THE STRUCTURAL ENGINEER OF RECORD PRIOR TO THE COMMENCEMENT OF WORK. ALL SUCH PENETRATIONS SHALL BE PROPERLY SEALED OFF AFTER INSTALLATION OF RACEWAY SO AS TO MAINTAIN THE STRUCTURAL, WATER PROOF, AND FIRE PROOF INTEGRITY OF THE WALL, FLOOR, OR ROOF SYSTEM PENETRATED.
4. SEAL ALL CONDUITS THAT PENETRATE THE FLOOR SLAB TO MAKE THEM WATER TIGHT. THE CONDUITS SHALL BE DRIED PRIOR TO INSTALLATION OF WIRE/CABLE AND SHALL BE SEALED AT TERMINATIONS.
5. ALL PENETRATIONS THROUGH FIRE RATED WALLS OR PARTITIONS SHALL BE MADE IN ACCORDANCE WITH U.L. "FIRE RESISTANCE DIRECTORY". PENETRATIONS SHALL BE SLEEVED AND SEALED WITH A UL APPROVED FIRE RATED SEALANT. REFER TO ARCHITECTURAL PLANS FOR FIRE RATED WALLS.
6. ALL EMPTY CONDUIT SYSTEMS SHALL CONTAIN A PULL WIRE FOR FUTURE PULLING OF CONDUITS.
7. OR FROM BUILDING CONTROL POWER DISTRIBUTION SYSTEM.

D. CONDUIT & RACEWAY

- 1. ALL WORK SHALL BE COORDINATED SO THAT INTERFERENCES ARE AVOIDED. PROVIDE ALL NECESSARY OFFSETS IN CONDUITS, RACEWAYS, ETC., REQUIRED TO PROPERLY INSTALL THE WORK. EXPOSED WORK MUST BE KEPT AS CLOSE AS POSSIBLE TO WALLS, CEILING, COLUMNS, ETC., SO AS TO TAKE UP MINIMUM AMOUNT OF SPACE; ALL OFFSETS, FITTINGS, ETC., REQUIRED SHALL BE PROVIDED WITHOUT ADDITIONAL EXPENSE TO THE OWNER. WORK SHALL BE COORDINATED WITH OTHER TRADES.
2. CONDUIT RUNS ARE DIAGRAMMATIC IN NATURE. CONTRACTOR IS RESPONSIBLE FOR SIZING AND LOCATING PULL BOXES PER NFPA 70 AND FOR COORDINATION WITH OTHER DISCIPLINES.
3. PENETRATIONS OF WALLS, FLOORS, AND ROOFS FOR THE PASSAGE OF ELECTRICAL RACEWAYS SHALL BE APPROVED BY THE STRUCTURAL ENGINEER OF RECORD PRIOR TO THE COMMENCEMENT OF WORK. ALL SUCH PENETRATIONS SHALL BE PROPERLY SEALED OFF AFTER INSTALLATION OF RACEWAY SO AS TO MAINTAIN THE STRUCTURAL, WATER PROOF, AND FIRE PROOF INTEGRITY OF THE WALL, FLOOR, OR ROOF SYSTEM PENETRATED.
4. SEAL ALL CONDUITS THAT PENETRATE THE FLOOR SLAB TO MAKE THEM WATER TIGHT. THE CONDUITS SHALL BE DRIED PRIOR TO INSTALLATION OF WIRE/CABLE AND SHALL BE SEALED AT TERMINATIONS.
5. ALL PENETRATIONS THROUGH FIRE RATED WALLS OR PARTITIONS SHALL BE MADE IN ACCORDANCE WITH U.L. "FIRE RESISTANCE DIRECTORY". PENETRATIONS SHALL BE SLEEVED AND SEALED WITH A UL APPROVED FIRE RATED SEALANT. REFER TO ARCHITECTURAL PLANS FOR FIRE RATED WALLS.
6. ALL EMPTY CONDUIT SYSTEMS SHALL CONTAIN A PULL WIRE FOR FUTURE PULLING OF CONDUITS.
7. OR FROM BUILDING CONTROL POWER DISTRIBUTION SYSTEM.

E. BRANCH CIRCUITS AND FEEDERS

- 1. CIRCUIT IS SHOWN DIAGRAMMATICALLY.
2. UNLESS OTHERWISE INDICATED, ALL CIRCUITS 100' OR LESS SHALL BE MINIMUM #12 AWG WIRE SIZE. CIRCUITS OVER 100' BUT LESS THAN 200' SHALL BE MINIMUM #10 AWG WIRE SIZE. CIRCUITS OVER 200' BUT LESS THAN 300' SHALL BE MINIMUM #8 AWG WIRE SIZE.
3. UNLESS OTHERWISE INDICATED, ALL CONDUCTORS SHALL BE COPPER, 98% CONDUCTIVITY CONTINUOUS FROM OUTLET TO OUTLET.
4. UNLESS OTHERWISE INDICATED, CONDUCTOR SIZES #12 AWG AND #10 AWG SHALL BE SOLID. CONDUCTOR SIZES #8 AWG AND LARGER MAY BE STRANDED.
5. A SEPARATE INSULATED EQUIPMENT GROUNDING CONDUCTOR SHALL BE PULLED WITH THE CIRCUIT CONDUCTORS FOR GROUNDING WHETHER OR NOT INDICATED ON THE DRAWINGS. METAL RACEWAY, OR A CABLE ARMOR OR SHEATH SHALL NOT BE USED AS THE ONLY EQUIPMENT GROUNDING CONDUCTOR.
6. HOMERUN CIRCUITS FOR ISOLATED GROUND RECEPTACLES SHALL BE SEPARATED FROM OTHER CIRCUITS. EACH CIRCUIT SHALL HAVE ITS OWN NEUTRAL CONDUCTOR AND EACH HOMERUN SHALL CONTAIN AN ISOLATED AND EQUIPMENT GROUND CONDUCTOR.

F. WIRING DEVICES

- 1. REFER TO ARCHITECTURAL DRAWINGS AND SPECIFICATIONS FOR LOCATION AND MOUNTING HEIGHT OF ALL WALL AND FLOOR MOUNTED ELEMENTS (OUTLETS, LIGHT SWITCHES, CONTROLLERS, POKE-THRU, ETC.). ALL WALL/FLOOR MOUNTED ITEMS SHALL BE INSTALLED IN ACCORDANCE WITH THE ARCHITECTURAL DIMENSIONED DRAWINGS. IF LOCATION FOR AN ITEM IS NOT SHOWN ON THE ARCHITECTURAL DRAWINGS, VERIFY THE EXACT LOCATION OF THE ITEM WITH THE ARCHITECT PRIOR TO INSTALLATION. THESE REQUIREMENTS APPLY TO ALL WALL/FLOOR TYPES IN ALL AREAS. DO NOT SCALE OR DIMENSION LOCATIONS FROM THESE DRAWINGS.
2. COORDINATE THE LOCATION AND INSTALLATION DETAIL OF OUTLETS IN MILLWORK WITH ARCHITECTURAL DRAWINGS (WALL ELEVATIONS, MILLWORK DETAILS, ETC.) AND WITH MILLWORK MANUFACTURER PRIOR TO ELECTRICAL ROUGH-IN.
3. WALL AND FLOOR MOUNTED POWER RECEPTACLES SHOWN NEAR DATA OUTLETS SHALL BE LOCATED WITHIN SIX (6) INCHES OF THE DATA OUTLET. LOCATE AT SAME MOUNTING HEIGHT UNLESS NOTED OTHERWISE.
4. VERIFY THE EXACT POWER CONNECTION TYPE AND NEMA CONFIGURATION OF RECEPTACLES FOR EQUIPMENT FURNISHED BY THE OWNER, OTHER TRADES, OR UNDER A SEPARATE SECTION OF THIS CONTRACT PRIOR TO ELECTRICAL ROUGH-IN.
5. ALL RECEPTACLES LOCATED OUTSIDE THE BUILDING ENVELOPE SHALL BE HOUSED IN ENCLOSURES THAT ARE RATED WEATHER-PROOF-WHILE-IN-USE AND SHALL BE EQUIPPED WITH GFCI FOR PERSONNEL PROTECTION.
6. ALL GFCI RECEPTACLES SHALL BE CONNECTED SO THAT ALL DEVICES ON THE SAME CIRCUIT AS THE GFCI RECEPTACLE DO NOT DE-ENERGIZE UPON TRIPPING. ALL GFCI RECEPTACLES SHALL INCLUDE A LOCK-OUT FUNCTION TO PROTECT THE USER OF MISWIRING DEVICES OR DEVICES THAT HAVE BEEN DAMAGED DUE TO DISABLING SURGES.

G. LIGHTING SYSTEM

- 1. REFER TO ARCHITECTURAL DRAWINGS AND SPECIFICATIONS FOR LOCATION OF ALL CEILING ELEMENTS (LIGHTS, SPRINKLERS, DIFFUSERS, ETC.). ALL CEILING MOUNTED ITEMS SHALL BE INSTALLED IN ACCORDANCE WITH THE ARCHITECTURAL DIMENSIONED DRAWINGS. IF LOCATION FOR AN ITEM IS NOT SHOWN ON THE ARCHITECTURAL DRAWINGS, VERIFY THE EXACT LOCATION OF THE ITEM WITH THE ARCHITECT PRIOR TO INSTALLATION. THESE REQUIREMENTS APPLY TO ALL CEILING TYPES IN ALL AREAS. DO NOT SCALE OR DIMENSION LOCATIONS FROM THESE DRAWINGS.
2. PROVIDE AND INSTALL ALL SUPPORTS FOR LIGHT FIXTURES, SUPPORTS SHALL BE INDEPENDENT OF THE SUPPORT DEVICES.
3. LIGHT SWITCHES / OCCUPANCY SENSORS LOCATED IN A ROOM SHALL CONTROL ALL THE LIGHT FIXTURES IN THAT ROOM UNLESS NOTED OTHERWISE. CONTRACTOR SHALL GANG TOGETHER ALL SWITCHES/DIMMERS UNDER A SINGLE COVER PLATE IN ALL AREAS THAT REQUIRE MORE THAN ONE SWITCH TO CONTROL ELECTRICAL DEVICES.
4. IN INSTANCES WHERE A TRACK LIGHTING SYSTEM, DIMMING SYSTEM, AND/OR LIGHTING CONTROL SYSTEM IS PROVIDED, THE CONTRACTOR SHALL COORDINATE ALL NECESSARY COMPONENTS OF SUCH SYSTEM(S) WITH THE MANUFACTURER PRIOR TO BID AND INCLUDE ALL NECESSARY ACCESSORIES TO INSTALL A COMPLETE AND FUNCTIONING SYSTEM.

H. 2-POST LIFT COORDINATION

- 1. LIFTS MAY BE PROVIDED AS PART OF PROJECT SCOPE OR BY USPS. REVIEW DRAWINGS AND LIFT SCHEDULE FOR SITE SPECIFIC INFORMATION.
2. MINIMUM VERTICAL CLEARANCE ABOVE ALL LIFTS IS 16'-3".
3. COORDINATE WITH GENERAL CONTRACTOR TO PROVIDE MINIMUM 16'-3" CLEARANCE ABOVE ALL NEW LIFTS, WHETHER LIFT(S) ARE PROVIDED AS PART OF SCOPE OF WORK FOR THE PROJECT OR PROVIDED BY OWNER. MAKE SAFE AND DISCONNECT ANY EQUIPMENT, DEVICES, LIGHTS, AND/OR CONDUIT WITH POWER RUNNING ALONG LIFT VEHICLE CLEARANCE AREA THAT INTERFERES WITH 16'-3" MINIMUM VERTICAL CLEARANCE REQUIREMENT. COORDINATE WITH GENERAL CONTRACTOR TO SHIFT/ADJUST ANY ELECTRICAL DEVICE/EQUIPMENT/RACEWAY/WIRING ELEMENT RUNNING ALONG VERTICAL CLEAR AREA BEYOND 16'-3".
4. ANY NEW LIGHTING, CONTROLS, CONDUIT AND APPURTENANCES ROUTED AS PART OF THE PROJECT SHALL NOT INTERFERE WITH VEHICLE LIFT CLEARANCE AREA.
5. REFER TO A500 FOR LIFT CLEARANCE DETAIL.
6. THIS SCOPE OF WORK DOES NOT APPLY TO ALIGNMENT LIFTS.

J. DEMO GENERAL NOTES

- 1. PROVIDE UPDATED, TYPE WRITTEN DIRECTORY OF ALL CORRECT CIRCUITS WITH LOAD DEFINITIONS FOR EACH PANEL BOARD. DIRECTORY SHALL BE LOCATED INSIDE PANEL DOOR.
2. INFORMATION PROVIDED ON THESE DRAWINGS HAVE BEEN TAKEN FROM DESIGN DRAWING AND FIELD OBSERVATIONS CONTRACTOR SHALL VERIFY ALL EXISTING CONDITIONS PRIOR TO PRICING AND COMMENCEMENT OF WORK.
3. WHERE EXISTING WALLS ARE DEMOLISHED, REMOVE ALL EXISTING ELECTRICAL DEVICES AND THEIR ASSOCIATED CONDUITS AND WIRING BACK TO THE POINT OF ORIGIN. ENERGIZE ALL EXISTING DEVICES THAT WERE INTERRUPTED DURING DEMOLITION. WHERE ENTIRE CIRCUITS ARE REMOVED, TURN THE CIRCUIT BREAKER OFF AND LABEL AS "SPARE".
4. PROVIDE FOR ANY AND ALL DEMOLITION WORK NECESSARY TO ACCOMMODATE ALL NEW CONSTRUCTION, INCLUDING ARCHITECTURAL, MECHANICAL, PLUMBING OR ELECTRICAL WORK.
5. IF DEMOLITION IS REQUIRED TO INSTALL AN ITEM, THE CONTRACTOR SHALL RESTORE THE AREA TO PREVIOUS CONDITION, OR REPLACE DAMAGED ITEMS WITH NEW ITEMS TO MATCH EXISTING.
6. DESIGNATION 'EX' REPRESENTS EXISTING DEVICE OR LIGHT FIXTURE TO REMAIN AS CIRCUITED AND SWITCHED UNLESS NOTED OTHERWISE. EXISTING LIGHT FIXTURES SHALL BE CLEANED AND REPAIRED AS REQUIRED.
7. A DEVICE WITH AN 'X' INDICATES EXISTING DEVICE TO BE REMOVED INCLUDING ALL ASSOCIATED CONDUIT AND WIRING.
8. A DEVICE WITH AN 'R' INDICATES EXISTING DEVICE TO BE RELOCATED INCLUDING ALL ASSOCIATED CONDUIT AND WIRING.
9. CONTRACTOR SHALL REMOVE ALL CONDUIT AND WIRING ASSOCIATED WITH DEVICES AND EQUIPMENT TO BE REMOVED AND/OR RELOCATED UNLESS NOTED OTHERWISE. PROVIDE AND INSTALL ALL NECESSARY DEVICES, EQUIPMENT AND ACCESSORIES REQUIRED TO MAINTAIN SERVICE TO ALL "EXISTING TO REMAIN" DEVICES AND EQUIPMENT THAT MAY BE INTERRUPTED DURING DEMOLITION.
10. WHERE EXISTING MECHANICAL/PLUMBING EQUIPMENT IS DEMOLISHED, REMOVE ALL RELATED ELECTRICAL FEEDS TO THE EQUIPMENT AND THEIR ASSOCIATED CONDUITS BACK TO THE POINT OF ORIGIN.
11. REFER TO ARCHITECTURAL PLANS FOR AREAS WHERE CEILING IS DEMOLISHED. REMOVE ALL LIGHTING FIXTURES AND ASSOCIATED CONDUIT AND WIRING FROM THESE LOCATIONS.

ELECTRICAL ABBREVIATIONS

Table with 2 columns: Symbol and Description. Includes abbreviations for AFC, AFF, AHJ, BFC, BOF, C, CB, C/B OR CKT BKR, CKT, C/CVT, CLG, CR, CUH, EC, ELEC, EMS, EVSE, EP, EWVC, EX, FA, FACP, FAP, FIX, FJU, FLR, FLUOR, FTP, FTS OR FTU, G, GND, GEN, GFCI, GFI, HP, HWAT, ICAND, IG, IGF, JB, KEF, LTG, LTS, LV, MATV, MCB, MCC, MDP, MH, MLO, MTD, MW, N, NC (N.C.), NEC, NEMA, NF, NIC, NO (N.O.), OH, PLUGMLD, PNL, PWR, RCPT(S) OR RECEPT, RF, SEF, SF, SO (S.O.), SP, ST (S.T.), SW, TEL, TF, TP, TVSS, UH, UG, UNO (U.N.O.), U.N.K, V, VFD, VP, VV, W, W/G, W/P, WP, WT, XFMR, X, XCR.

POWER SYMBOLS LEGEND

Table with 3 columns: Symbol, Description, and MNTG. HT. (U.N.O.). Includes symbols for SINGLE RECEPTACLE, DUPLEX RECEPTACLE, DUPLEX RECEPTACLE ON EMERGENCY CIRCUIT, DUPLEX RECEPTACLE GFCI, DUPLEX RECEPTACLE, GFCI, TAMPER RESISTANT, WEATHER RESISTANT, HOUSED IN A WEATHERPROOF-WHILE-IN-USE ENCLOSURE, QUADRUPLEX RECEPTACLE, QUADRUPLEX RECEPTACLE ON EMERGENCY CIRCUIT, SPECIAL PURPOSE RECEPTACLE, FLOOR MOUNTED RECEPTACLE, CEILING MOUNTED RECEPTACLE, JUNCTION BOX, MOTOR, WALL MOUNTED JUNCTION BOX, POWER POLE, PLUG/MOLD, DISCONNECT SWITCH, DISCONNECT SWITCH NON-FUSED, MANUAL MOTOR STARTER SWITCH, EMERGENCY POWER OFF BUTTON, 208Y/120V PANELBOARD, 480Y/277V PANELBOARD, 208Y/120V DISTRIBUTION PANELBOARD, 480Y/277V DISTRIBUTION PANELBOARD, SWITCHBOARD, STEP-DOWN TRANSFORMER, AUTOMATIC TRANSFER SWITCH, GROUND BAR, AUTOMATIC TRANSFER SWITCH ANNUNCIATOR PANEL.

GENERAL NOTATIONS AND MOUNTING HEIGHTS

NOTE 1: ALL MOUNTING HEIGHTS REFER TO BOTTOM OF DEVICE, UNLESS OTHERWISE INDICATED.
A) 24" AFF INDICATES TO BOTTOM OF DEVICE;
B) 42" AFF INDICATES TO CENTER OF DEVICE;
C) 60" AFF INDICATES TO BOTTOM OF DEVICE;
D) 80" AFF INDICATES TO BOTTOM OF DEVICE;
NOTE 2: CONFIRM ALL BACKBOX SIZE WITH VENDOR SHOP DRAWINGS PRIOR TO ELECTRICAL ROUGH-IN.
LEGEND NOTES: DENOTES "SEE LEGEND NOTE NO. 2"
DENOTES: REFERENCE DETAIL 02 ON DRAWING (SHEET) E100
DENOTES: REFERENCE ENLARGED DETAIL PLAN 02 ON DRAWING (SHEET) E100
EQUIPMENT (ID) NUMBER FOR OWNER PROVIDED EQUIPMENT. REFER TO OWNER'S EQUIPMENT BOOK / FFE DOCUMENTS FOR DEFINITION AND REQUIREMENTS.

CODES AND STANDARDS

Table with 2 columns: Year and Code Name. Includes Washington State Building Code, Washington State Existing Building Code, ICC/ANSI A117.1 Accessible and Usable Buildings and Facilities Design Standard, International Energy Conservation Code (IECC) with State Amendments, Washington State Mechanical Code, Fuel Gas Code of Washington, Washington State Plumbing Code, National Electric Code (NEC / NFPA 70), International Fire Code (IFC), USPS Standards for Facility Accessibility (RE-4), USPS Standards Design Criteria, USPS Building and Site Security Requirements Handbook RE-5.

LIGHTING SYMBOLS LEGEND

Table with 3 columns: Symbol, Description, and MNTG. HT. (U.N.O.). Includes symbols for 2'x4' LIGHT FIXTURE, 2'x4' LIGHT FIXTURE (EMERGENCY), 2'x2' LIGHT FIXTURE, 2'x2' LIGHT FIXTURE (EMERGENCY), WALL MOUNTED LINEAR FIXTURE, WALL MOUNTED LINEAR FIXTURE (EMERGENCY), RECESSED/SURFACE MOUNTED LINEAR FIXTURE, RECESSED/SURFACE MOUNTED LINEAR FIXTURE (EMERGENCY), RECESSED/SURFACE DOWNLIGHT FIXTURE, RECESSED/SURFACE DOWNLIGHT FIXTURE (EMERGENCY), WALL MOUNTED FIXTURE, WALL MOUNTED FIXTURE (EMERGENCY), RECESSED DOWNLIGHT FIXTURE WITH WALL WASH, RECESSED DOWNLIGHT FIXTURE WITH WALL WASH (EMERGENCY), HANGING RECTANGULAR PENDANT FIXTURE, HANGING RECTANGULAR PENDANT FIXTURE (EMERGENCY), HANGING CIRCULAR PENDANT FIXTURE, HANGING CIRCULAR PENDANT FIXTURE (EMERGENCY), EMERGENCY LIGHTING UNIT, END MOUNTED EXIT SIGN, END MOUNTED EXIT SIGN, WALL MOUNTED EXIT SIGN, WALL PACK LIGHT FIXTURE, WALL PACK LIGHT FIXTURE (EMERGENCY), EXTERIOR LIGHT POLE FIXTURE, SPOT/FLOOD LIGHT FIXTURE, WALL SWITCH SPST, WALL DIMMER SWITCH, KEY OPERATED WALL SWITCH, LOW VOLTAGE WALL SWITCH, WALL SWITCH WITH PILOT LIGHT, WALL SWITCH WITH ADJUSTABLE COUNTDOWN TIMER.

LIGHTING NOTES:
1. ALL SYMBOLS SHOWN MAY NOT APPEAR IN ALL DRAWINGS. SYMBOLS ARE SHOWN SCHEMATIC AND MAY NOT BE TO SCALE.
2. REFER TO LIGHT FIXTURE SCHEDULE FOR SPECIFIC FIXTURE INFORMATION.
3. REFER TO ARCHITECTURAL REFLECTED CEILING PLANS FOR MOUNTING HEIGHTS. IT IS THE INTENT, UNLESS NOTED OTHERWISE, THAT SURFACE AND RECESSED FIXTURES ARE TO BE MOUNTED AT ARCHITECTS CEILING PLANE.
4. REFER TO ARCHITECTURAL REFLECTED CEILING PLANS AND ELEVATIONS FOR MOUNTING HEIGHTS OF PENDANT FIXTURES. REFER TO LIGHTING FIXTURE SCHEDULE FOR PENDANT MATERIAL.
5. REFER TO ARCHITECTURAL DRAWINGS FOR TYPICAL MOUNTING HEIGHTS. WHERE MOUNTING HEIGHT IS NOT INDICATED BY ARCHITECT, PROVIDE AT 42" AFF TO CENTER.

OCCUPANCY SENSOR/CONTROLS SYMBOLS LEGEND

Table with 3 columns: Symbol, Description, and MNTG. HT. (U.N.O.). Includes symbols for OCCUPANCY SENSOR, DUAL TECHNOLOGY, OCCUPANCY SENSOR, ULTRASONIC, VACANCY SENSOR, DUAL TECHNOLOGY, WALL SWITCH OCCUPANCY SENSOR CONTROL, WALL TIMER SWITCH OCCUPANCY SENSOR CONTROL, WALL SWITCH VACANCY SENSOR CONTROL.

OCCUPANCY SENSOR/CONTROLS NOTES:
1. REFER TO ARCHITECTURAL ELEVATIONS FOR EXACT MOUNTING HEIGHTS OF ALL DEVICES.

SHEET INDEX

Table with 2 columns: Sheet Number and Sheet Name. Lists sheets E001 through E501 and their corresponding descriptions.

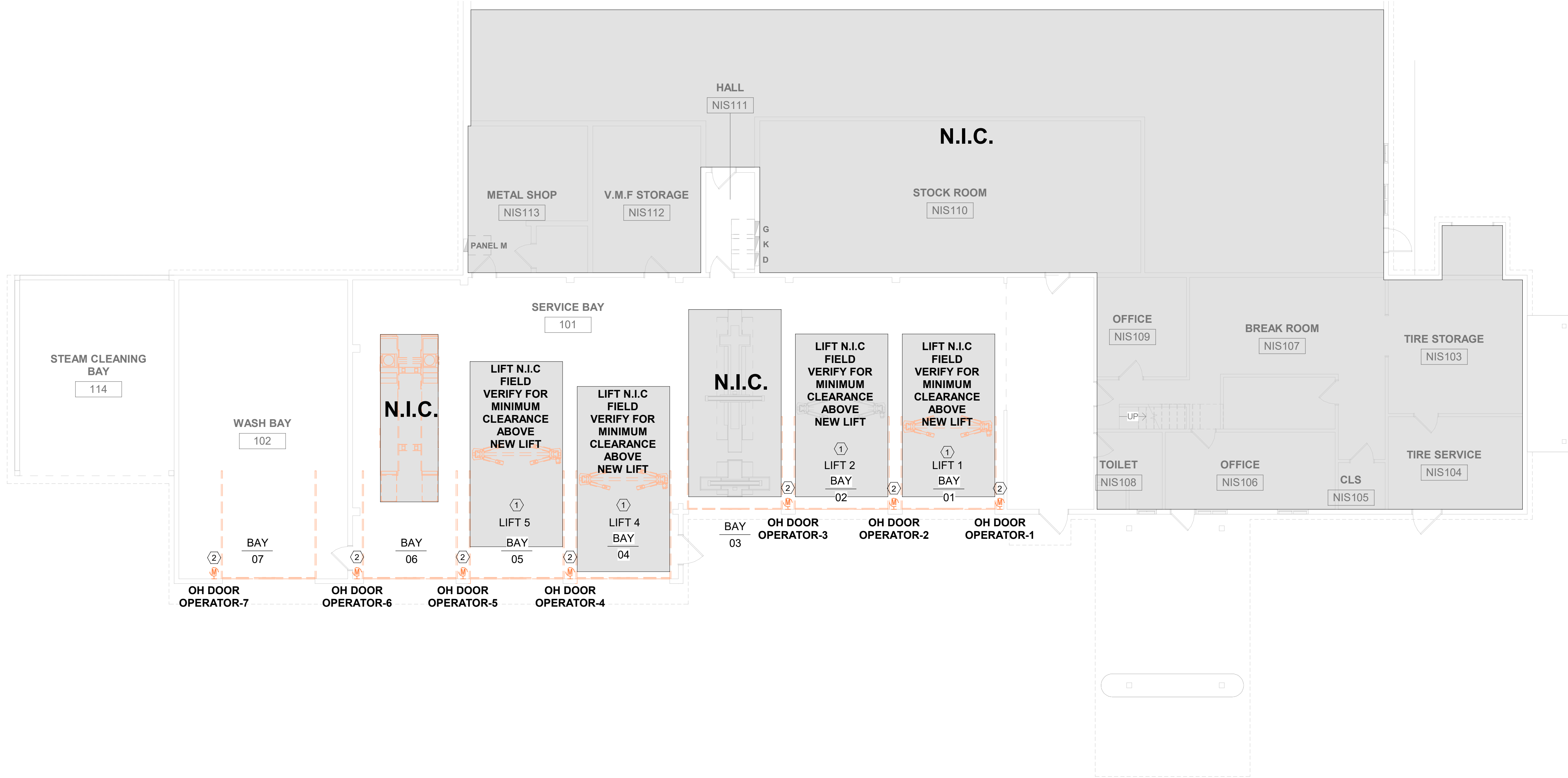

DEMO NOTES - POWER

- A. DEMOLITION DRAWINGS ARE BASED ON EXISTING PLANS AND LIMITED FIELD INVESTIGATION.
- B. PROVIDE DEMOLITION WORK SHOWN ON THE DRAWINGS AND RELATED AND INCIDENTAL DEMOLITION WORK REQUIRED TO COMPLETE NEW CONSTRUCTION WORK.
- C. FIELD VERIFY EXISTING CONDITIONS PRIOR TO THE START OF DEMOLITION OPERATIONS. BRING ANY DISCREPANCIES WHICH MAY SIGNIFICANTLY AFFECT DEMOLITION OR NEW CONSTRUCTION WORK TO THE ATTENTION OF THE ENGINEER FOR REVIEW.
- D. PROTECT EXISTING CONSTRUCTION TO REMAIN FROM DAMAGE DURING DEMOLITION AND/OR NEW CONSTRUCTION OPERATIONS.

LEGEND NOTES

- 1. COORDINATE WITH GENERAL CONTRACTOR TO DISCONNECT AND MAKE SAFE ANY EQUIPMENT ABOVE THIS LIFT. EQUIPMENT AND UTILITY ROUTING SHALL BE ADJUSTED TO INCREASE CLEARANCE ABOVE LIFT AREA TO 18'-3" A.F.F. MINIMUM. FIELD VERIFY EXTENT OF WORK (CONDUITS, ETC.) THAT SHALL BE MODIFIED TO ACCOMMODATE MIN. CLEARANCE HEIGHT DURING PREPROPOSAL MEETING.
- 2. DISCONNECT, DEMO EXISTING OVERHEAD DOOR CONNECTIONS AND ASSOCIATED CONDUITS. CONNECT NEW OVERHEAD DOOR TO EXISTING PANEL AND CIRCUIT BREAKERS SAVED FROM DEMOLITION. EC HAS TO FIELD VERIFY THAT THE EXISTING CIRCUIT BREAKER ARE PROPER WORKING CONDITION, IF NOT REPLACE WITH NEW CIRCUIT BREAKER.

DEMO NOTES - LIGHTING

- A. LIGHT FIXTURES AND ASSOCIATED LIGHTING CIRCUITRY & CONTROLS WITHIN THE INDICATED LIGHTING DEMOLITION AREAS TO BE REMOVED. CONTRACTOR SHALL REMOVE CONDUCTORS BACK TO SOURCE. REFER TO NEW WORK LIGHTING PLANS PRIOR TO START OF DEMOLITION. TRACE LIGHTING BACK TO PANEL AND VERIFY CIRCUIT NUMBER. ONLY VERTICAL CONDUIT HIDDEN IN BLOCK OR FINISHED WALLS MAY BE RE-USED TO MINIMIZE PATCHWORK. DISCONNECT AND REMOVE EXISTING LIGHT FIXTURE AND PREPARE PANELS FOR NEW CIRCUIT.
- B. DISCONNECT AND REMOVE LIGHT SWITCHES AND ASSOCIATED WIRING AND CONDUIT ON EXISTING WALLS THAT ARE TO REMAIN WITHIN INDICATED LIGHTING DEMOLITION AREAS. REMOVE BRANCH CIRCUITS BACK TO EXISTING PANELS AND MARK AS "SPARE." LIGHTING CONTROLS TO BE REPLACED IN NEW WORK PHASE. PLACE NEW LIGHTING CONTROLS DEVICES IN LOCATION TO MINIMIZE PATCH WORK.
- C. DISCONNECT EXTERIOR BUILDING MOUNTED LIGHTS. COORDINATE WITH GC TO PATCH AFTER DEMOLITION.

1 ELECTRICAL DEMOLITION PLAN - POWER
ED100 SCALE: 1/8" = 1'-0"

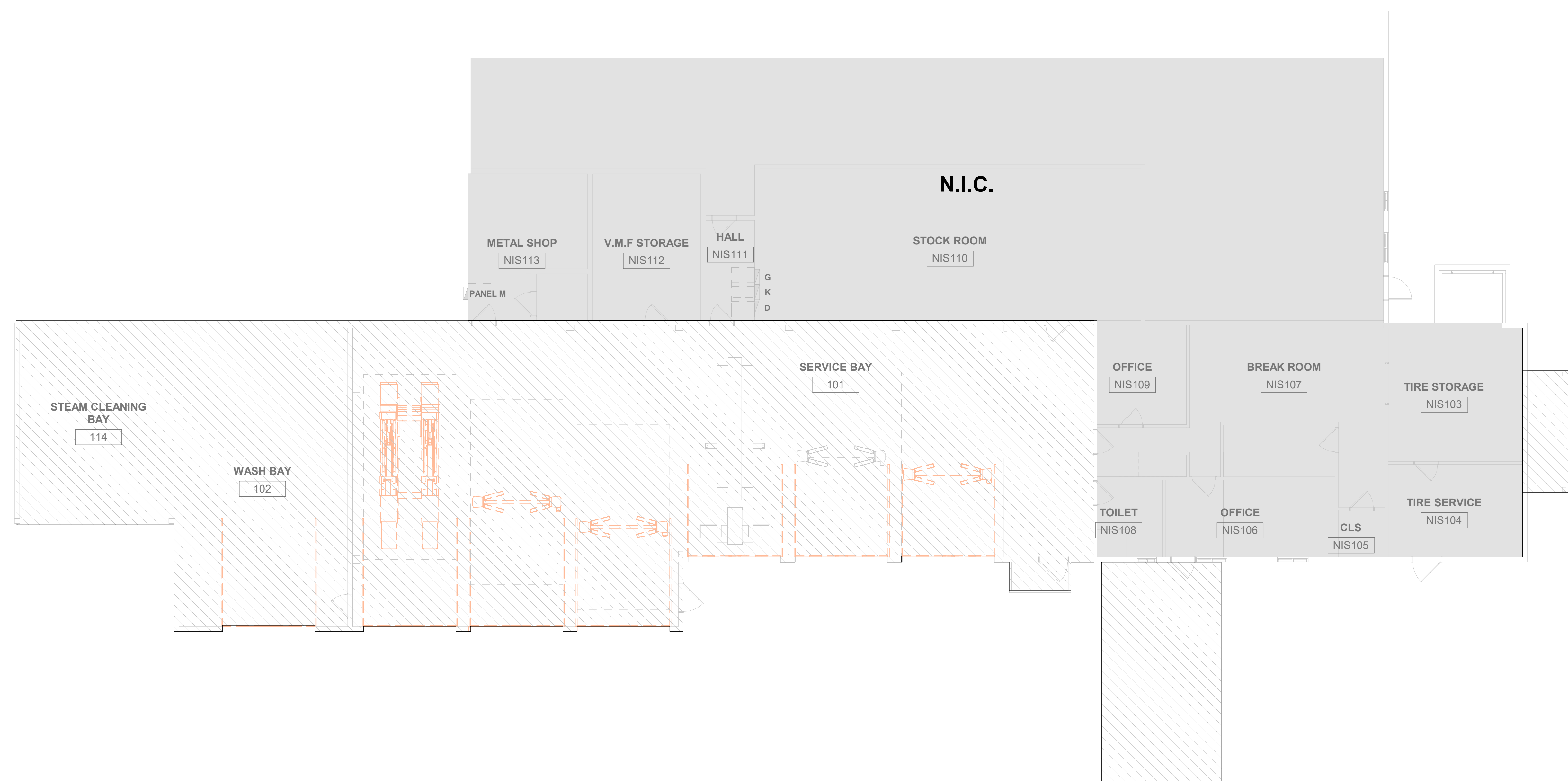

2 ELECTRICAL DEMOLITION PLAN - LIGHTING
ED100 SCALE: 1/8" = 1'-0"

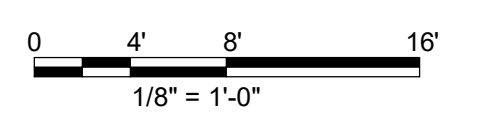

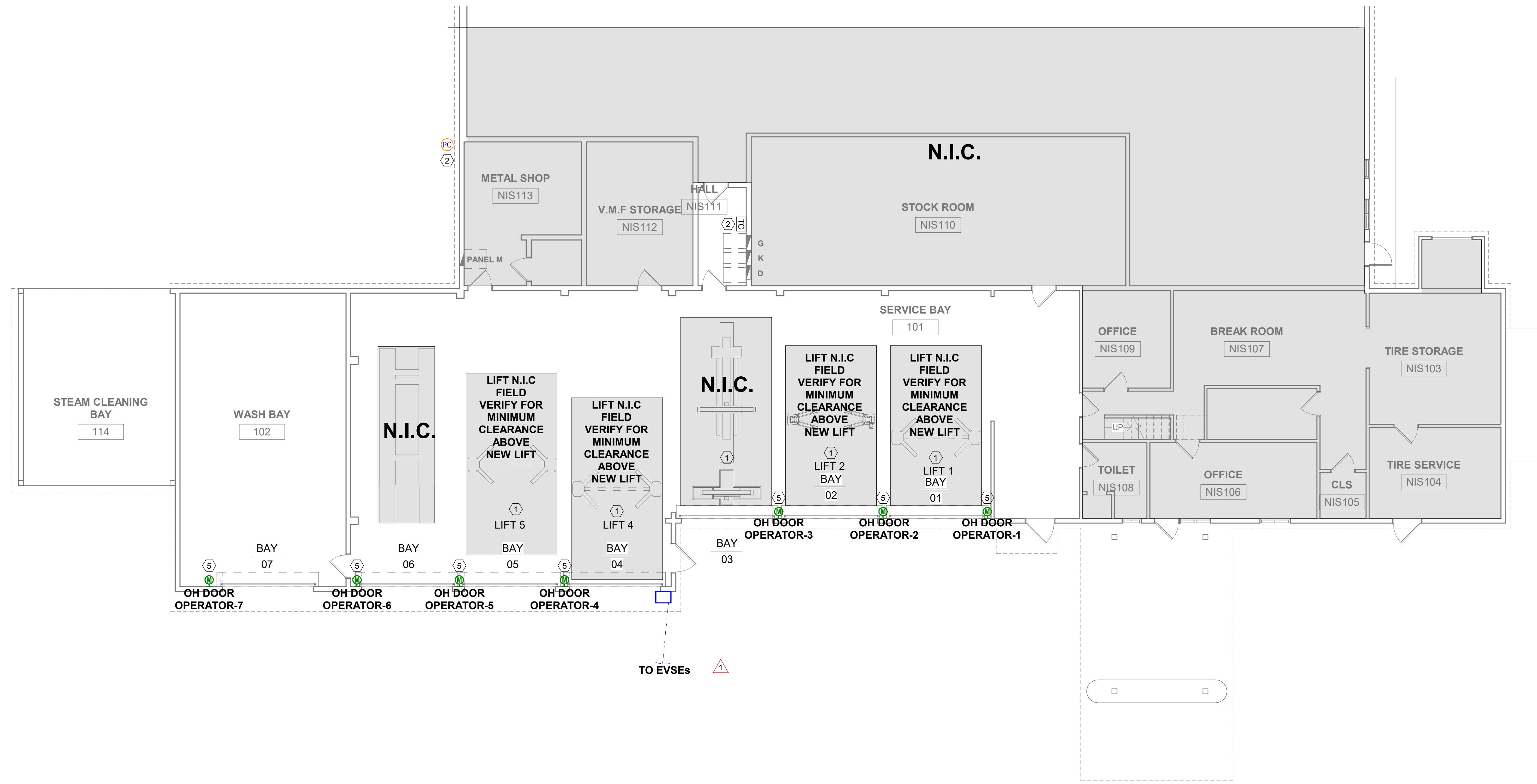

GENERAL NOTES

- A. REFER TO E001 FOR SYMBOL LEGEND, ABBREVIATIONS, AND NOTES.
- B. REFER TO E400 FOR ONE-LINE DIAGRAMS, AND PANEL SCHEDULES.
- C. REFER TO E401 FOR LIGHTING FIXTURE SCHEDULE AND LIGHTING CONTROLS SCHEDULE.
- D. REFER TO E500s SECTION FOR DETAILS.
- E. COORDINATE WITH GENERAL CONTRACTOR FOR FINAL LIGHT LOCATIONS WITH VERIFIED EXISTING BUILDING DIMENSIONS AND FINAL LIFT LOCATIONS TO MAINTAIN CLEARANCES AROUND AND ABOVE LIFT FOR VEHICLES.

LEGEND NOTES

- 1. COORDINATE WITH GENERAL CONTRACTOR TO DISCONNECT AND MAKE SAFE ANY EQUIPMENT ABOVE THIS LIFT. EQUIPMENT AND UTILITY ROUTING SHALL BE ADJUSTED TO INCREASE CLEARANCE ABOVE LIFT AREA TO 16'-3" A.F.F. MINIMUM. FIELD VERIFY EXTENT OF WORK (CONDUITS, ETC.) THAT SHALL BE MODIFIED TO ACCOMMODATE MIN. CLEARANCE HEIGHT DURING PREPROPOSAL MEETING.
- 2. CANOPY AND EXTERIOR WALL MOUNTED LIGHTS ARE CONTROLLED BY PHOTOCELL AND TIME SWITCH. REFER TO E500s SECTION FOR SITE LIGHTING CONTROL DETAILS.
- 3. PROVIDE NEMA 6P ENCLOSURES FOR LIGHTING CONTROL DEVICES IN WASH BAY.
- 4. TIME SWITCH FOR HIGH OUTPUT PROGRAMMED FOR MAXIMUM OF 4 HRS. REFER TO LIGHTING CONTROL SCHEDULE ON E500s SECTION FOR MORE INFORMATION.
- 5. DISCONNECT, DEMO EXISTING DOOR OPERATOR AND MOTOR UNITS. INSTALL NEW DOOR OPERATOR AND MOTOR UNITS IN SAME LOCATIONS AS EXISTING UNITS AND CONNECT TO EXISTING PANEL AND CIRCUITBREAKERS. REFER TO SHEET E500s SECTION FOR MOTOR DETAILS.
- 6. CIRCUIT NEW BATTERY-BACKED EMERGENCY LIGHT FIXTURE TO EXISTING INTERIOR LIGHTING CIRCUIT. PROVIDE UNSWITCHED HOT CONDUCTOR TO SENSE NORMAL POWER LOSS.

1 ELECTRICAL POWER PLAN
SCALE: 1/8" = 1'-0"

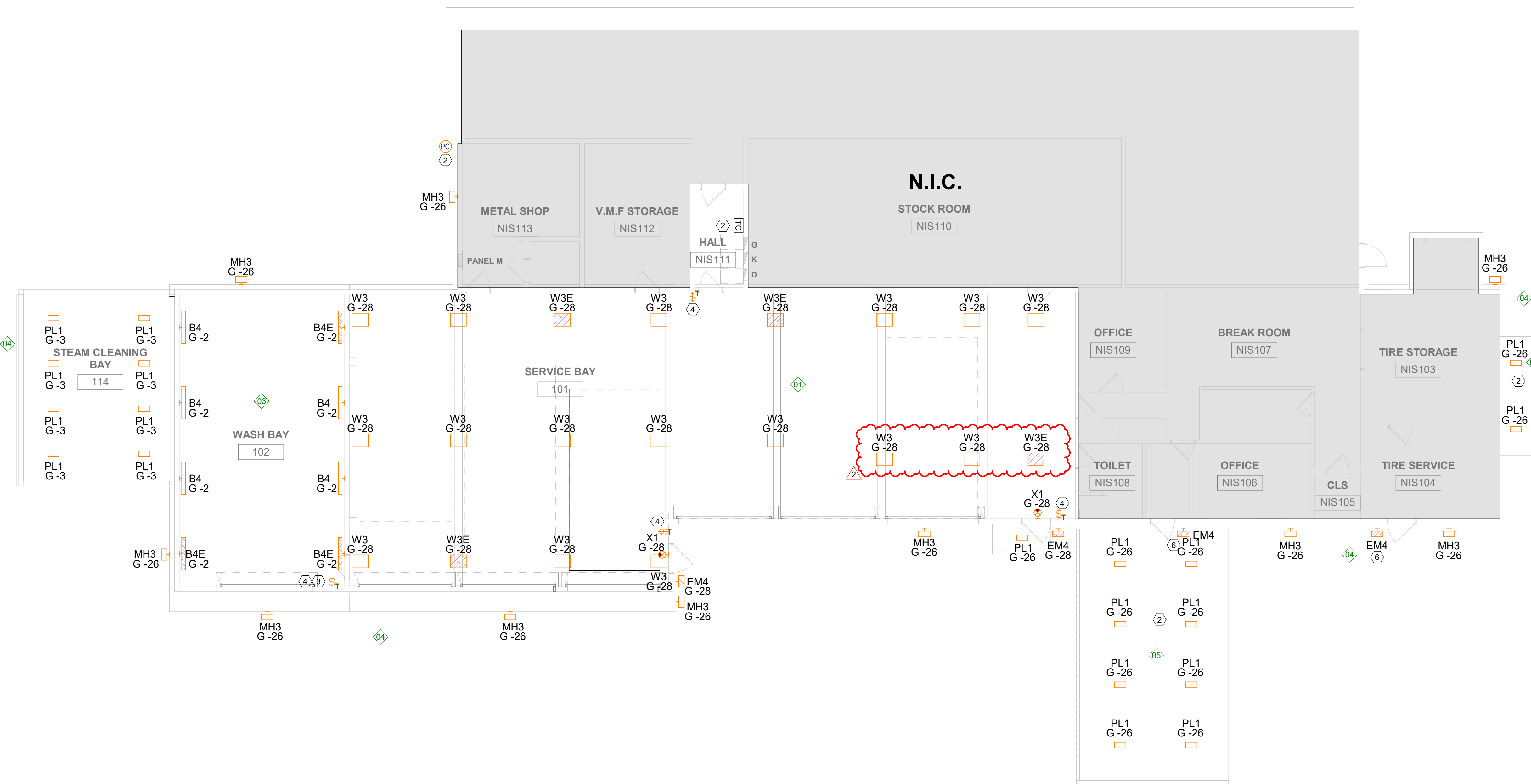

2 ELECTRICAL LIGHTING PLAN
SCALE: 1/8" = 1'-0"

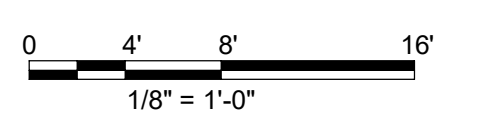

DATE & TIME: 2024-05-03 10:56:57 AM

COPPER WIRE & CONDUIT SCHEDULE									
TAG	AMPACITY	PHASE		NEUTRAL		GROUND		CONDUIT	
		NO. WIRES	SIZE (AWG OR KCML)	NO. WIRES	SIZE (AWG/KCML)	NO. WIRES	SIZE (AWG/KCML)	QTY.	SIZE
100	100	3	#3	-	-	1	#8	1	1 1/4"
100/2	100	2	#1	-	-	1	#6	1	1 1/4"
100N	100	3	#3	1	#3	1	#8	1	1 1/4"

NOTES:

- SIZES BASED ON THHN/THWN/THWN-2 CONDUCTORS AND PVC/EMT CONDUIT SIZES IN NEC TABLE 9. EXTERIOR CONDUCTORS SHALL BE 90° XHHW
- AMPACITY BASED ON 80°C RATING
- FEEDERS SERVING TRANSFORMERS DO NOT REQUIRE A GROUND. FOR TRANSFORMERS GEC, MATCH SIZE OF EGC SHOWN ON FEEDER SCHEDULE.
- COMPACT STRANDED ALUMINUM CONDUCTORS MAY BE USED FOR CONDUCTORS #1/0 AND LARGER IF EQUIPPED WITH COMPRESSION LUGS AND INSTALLED PER MANUFACTURER'S INSTRUCTIONS.

ELECTRICAL LOAD ANALYSIS (984- TACOMA VMF)	
UTILITY PROVIDER	TACOMA POWER
UTILITY CONTACT	Jordan Whiteley jwhiteley@cityoftacoma.org 253-244-8057
VMF FED BY MAIN BUILDING	YES
EXISTING MAIN BUILDING TRANSFORMER SIZE (IF APPLICABLE)	225kVA
VMF DISTRIBUTION VOLTAGE	208/120 V
EXISTING VMF TRANSFORMER SIZE	N/A
EXISTING VMF DISTRIBUTION SIZE (MCB)	1200 A
VMF BUILDING CAPACITY (80% OF MCB)	960 A
MAX KW AVAILABLE	225 KW
EXISTING PEAK LOAD MONTH	85 KW
NEC EXISTING LOAD FACTOR OF 25% PEAK	21.25 KW
REMAINING CAPACITY	118.75 KW
ADDED CHARGER LOAD	(2) CHARGERS AT 16,640 W EACH =33.3KW (208V 1Ø)
UTILITY UPGRADE NEEDED	NO
FEEDER FROM MAIN BUILDING UPGRADE NEEDED (IF APPLICABLE)	NO
NOTES	PEAK CONSUMPTION INFORMATION OBTAINED FROM BILLS

NOTES: SCOPE OF WORK IS RENOVATION OF EXISTING BUILDING. ONLY NEW/ADDED LOADS ARE SHOWN ON PANEL SCHEDULES.

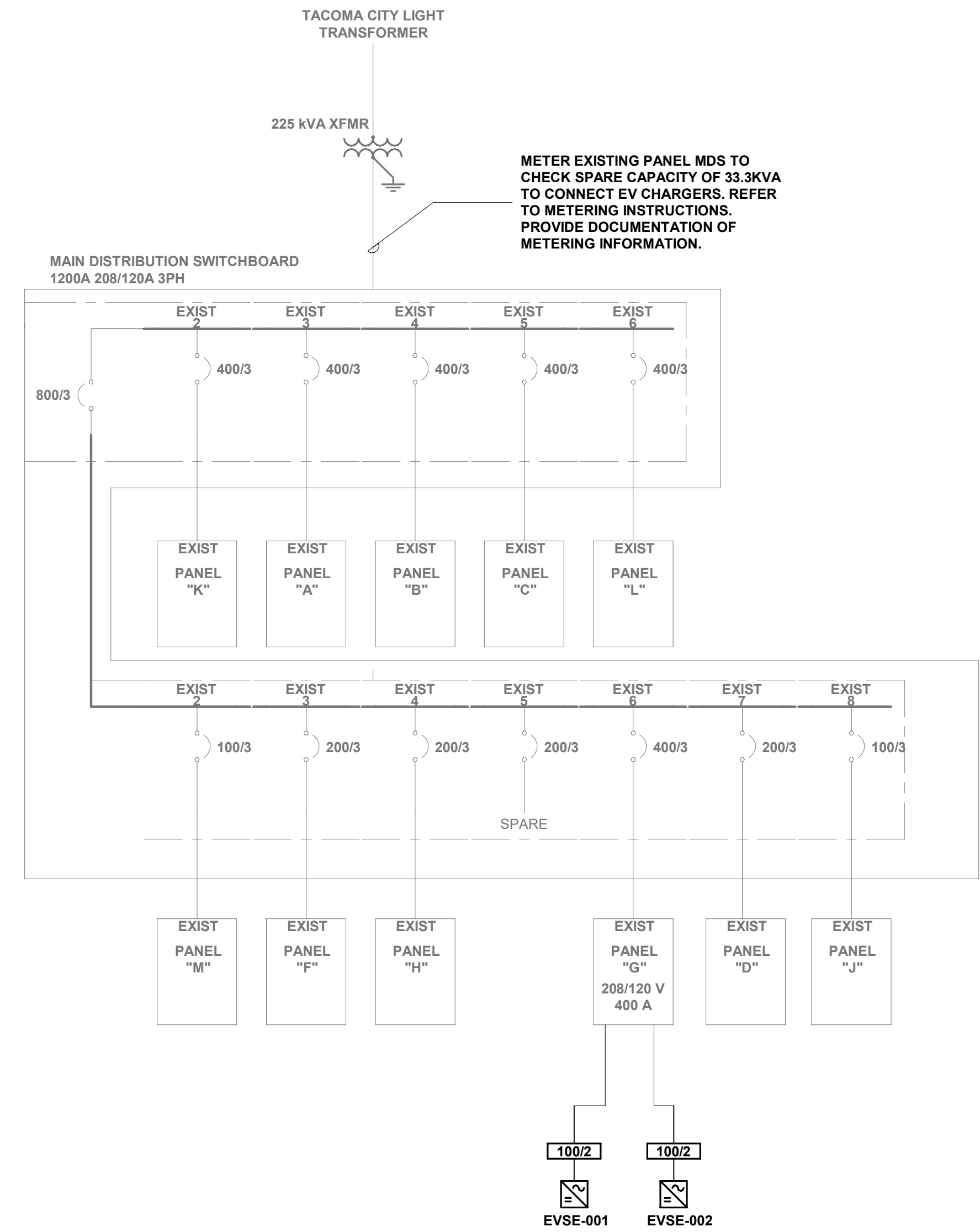
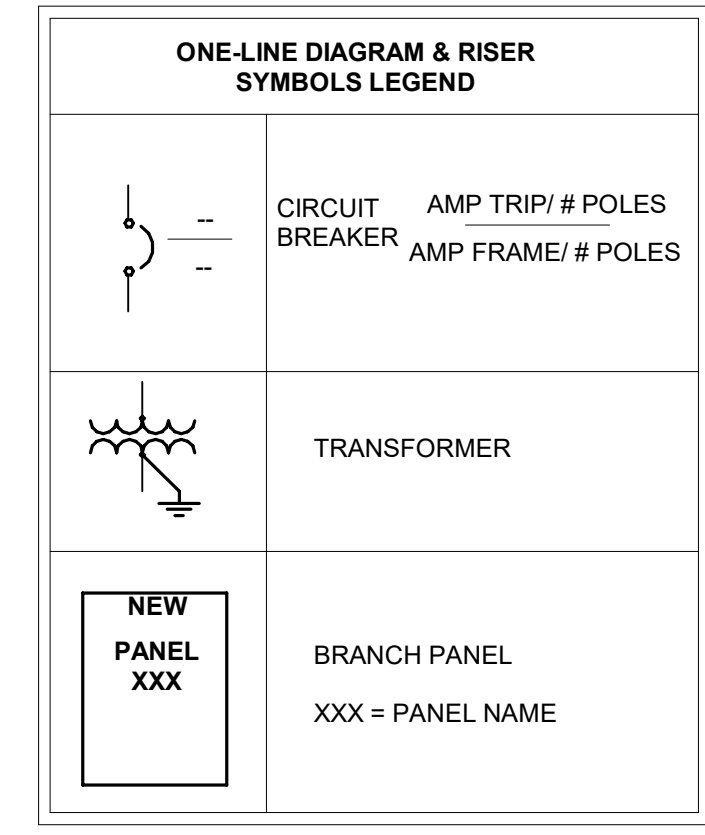

1 ELECTRICAL ONE-LINE DIAGRAM
SCALE: NTS

TRANSFORMER SCHEDULE											
IDENTIFICATION	KVA	PRIMARY VOLTAGE	SECONDARY VOLTAGE	PHASE	ENCLOSURE TYPE	MOUNTING STYLE	LOCATION	K-RATING	WINDINGS	TEMPERATURE RATING	NOTES

LIFTS ELECTRICAL REQUIREMENTS SCHEDULE																						
NAME	DESCRIPTION	LOCATION	HP	VOLTAGE	PHASE	MCA	MOCP	ENCLOSURE TYPE	FURNISHED BY	INSTALLED BY	DISCONNECT			CONTROL DEVICE			FEEDER INFORMATION					REMARKS
											TYPE	SWITCH/ FUSE SIZE	LOCATION	FURNISHED BY	WIRED BY	TYPE	PANEL	CIRCUIT	(L.C.) QTY	LINE	(GND) QTY	

OVERHEAD DOOR ELECTRICAL REQUIREMENT SCHEDULE																								
NAME	DESCRIPTION	LOCATION	HP	VOLTAGE	PHASE	MCA	MOCP	ENCLOSURE TYPE	FURNISHED BY	INSTALLED BY	DISCONNECT			CONTROL DEVICE			FEEDER INFORMATION					REMARKS		
											TYPE	SWITCH/ FUSE SIZE	LOCATION	FURNISHED BY	WIRED BY	TYPE	PANEL	CIRCUIT	(L.C.) QTY	LINE	(GND) QTY		GROUND	(CNDT) QTY
OH DOOR OPERATOR-1	MODEL RHX	SERVICE BAY	0.5	120 V	1	4 A	15 A	NEMA 1	E.C	E.C	E.C	15A/1P	OPERATOR CONTROLS	E.M	E.M	C.B	G	1	2	#6 COPPER	1	#8 COPPER	1	1"
OH DOOR OPERATOR-2	MODEL RHX	SERVICE BAY	0.5	120 V	1	4 A	15 A	NEMA 1	E.C	E.C	E.C	15A/1P	OPERATOR CONTROLS	E.M	E.M	C.B	G	50	2	#6 COPPER	1	#8 COPPER	1	1"
OH DOOR OPERATOR-3	MODEL RHX	SERVICE BAY	0.5	120 V	1	4 A	15 A	NEMA 1	E.C	E.C	E.C	15A/1P	OPERATOR CONTROLS	E.M	E.M	C.B	G	52	2	#6 COPPER	1	#8 COPPER	1	1"
OH DOOR OPERATOR-4	MODEL RHX	SERVICE BAY	0.5	120 V	1	4 A	15 A	NEMA 1	E.C	E.C	E.C	15A/1P	OPERATOR CONTROLS	E.M	E.M	C.B	G	48	2	#6 COPPER	1	#8 COPPER	1	1"
OH DOOR OPERATOR-5	MODEL RHX	SERVICE BAY	0.5	120 V	1	4 A	15 A	NEMA 1	E.C	E.C	E.C	15A/1P	OPERATOR CONTROLS	E.M	E.M	C.B	G	44	2	#6 COPPER	1	#8 COPPER	1	1"
OH DOOR OPERATOR-6	MODEL RHX	SERVICE BAY	0.5	120 V	1	4 A	15 A	NEMA 1	E.C	E.C	E.C	15A/1P	OPERATOR CONTROLS	E.M	E.M	C.B	G	46	2	#6 COPPER	1	#8 COPPER	1	1"
OH DOOR OPERATOR-7	MODEL RHX	WASH BAY	0.5	120 V	1	4 A	15 A	NEMA 4	E.C	E.C	E.C	15A/1P	OPERATOR CONTROLS	E.M	E.M	C.B	G	5	2	#6 COPPER	1	#8 COPPER	1	1"

NOTES:
1. IF EXISTING CB HAS RATING EQUAL TO OR GREATER THAN 15A, USE EXISTING CB

EVSE SCHEDULE											
EVSE #	EV KIT #	DESCRIPTION	LOCATION	PHASE	VOLTS	MAX CURRENT	ELECTRICAL OUTPUT (W)	CB RATING	POLES	FEEDER INFORMATION	REMARKS
EVSE-001	CP001	208V 1Ø - 80A (100A BREAKER)	EXTERIOR	1	208 V	80 A	16,640	100 A	2	G	30.32
EVSE-002	CP001	208V 1Ø - 80A (100A BREAKER)	EXTERIOR	1	208 V	80 A	16,640	100 A	2	G	34.36

DATE & TIME: 2024-05-03 10:56:59 AM

Copyright 2006-2013, United States Postal Service
 WSP USA INC. 2711 BROADWAY ST. LOUIS, MO 63102
 UNITED STATES POSTAL SERVICE
 TACOMA VMF 3825 S WARNER ST TACOMA, WA 98409
 90% DESIGN SUBMITTAL
 Date: Jan 26, 2024
 Revision 2
 E400 ELECTRICAL ONE-LINE DIAGRAM
 Project: TACOMA VMF
 USPS File Number: E10234



Tacoma, WA
VMF NGDV-EV Upgrade
Specification

January 26, 2024

DOCUMENT 000010

TABLE OF CONTENTS

INTRODUCTORY INFORMATION

Document 000001 Project Title Page
Document 000010 Table of Contents

SCHEDULE, CLAUSES AND ATTACHMENTS, AND SOLICITATION REQUIREMENTS**SPECIFICATIONS**

DIVISION 1 - GENERAL REQUIREMENTS

Section	011000	Summary of Work
Section	011104	Contract Documents
Section	013200	Construction Progress Documentation
Section	013300	Submittal Procedures
Section	013300A	Submittal Procedures Attachment A - Schedule of Values
Section	013543	Environmental Procedures
Section	013543A	Environmental Procedures Attachment A - Safety and Health Guide for Contractors
Section	013543B	Environmental Procedures Attachment B – Certificate of Asbestos and Lead-Based Paint
Section	014000	Quality Requirements
Section	015000	Temporary Facilities and Controls
Section	015600	Temporary Barriers and Enclosures
Section	016000	Product Requirements
Section	017300	Execution
Section	017419	Construction Waste Management and Disposal
Section	017419A	Construction Waste Management and Disposal Attachment A – Summary of Solid Waste Disposal and Diversion
Section	017419B	Construction Waste Management and Disposal Attachment B – Resource Conservation and Recovery Act - Project Summary
Section	017704	Closeout Procedures and Training

DIVISION 2 – EXISTING CONDITIONS

Section 024113 Selective Site Demolition

DIVISION 3 - CONCRETE

Section 031000 Concrete Forming and Accessories
 Section 032000 Concrete Reinforcement
 Section 033000 Cast-In-Place Concrete

DIVISION 4 - MASONRY

Not Used

DIVISION 5 - METALS

Section 055000 Metal Fabrications

DIVISION 6 – WOOD, PLASTICS AND COMPOSITES

Not Used

DIVISION 7 - THERMAL AND MOISTURE PROTECTION

000010 - 1

Section 078400 Firestopping
Section 079200 Joint Sealants

DIVISION 8 - OPENINGS

Section 083323 Overhead Coiling Doors

DIVISION 9 – FINISHES

Section 096723 Resinous Flooring
Section 099100 Painting

DIVISION 10 - SPECIALTIES

Section 101404 Postal Signage

DIVISION 11 - EQUIPMENT

Not Used

DIVISION 12 - FURNISHINGS

Not Used

DIVISION 13 - SPECIAL CONSTRUCTION

Not Used

DIVISION 14 - CONVEYING EQUIPMENT

Not Used

DIVISION 21 - FIRE SUPPRESSION

Not Used

DIVISION 22 - PLUMBING

Not Used

DIVISION 23 – HEATING, VENTILATING AND AIR CONDITIONING

Not Used

DIVISION 25 - INTEGRATED AUTOMATION

Not Used

DIVISION 26 - ELECTRICAL

Section 260500 Common Work Results for Electrical
Section 260519 Low-Voltage Electrical Power Conductors and Cables
Section 260533 Raceway and Boxes for Electrical Systems
Section 260623 Lighting Control Devices
Section 262200 Secondary Dry-Type Transformers
Section 262416 Panelboards
Section 262726 Wiring Devices
Section 262816 Enclosed Switches and Circuit Breakers
Section 265100 Interior Lighting (LED – Solid State)
Section 265600 Exterior Lighting

DIVISION 27 – COMMUNICATIONS

Not Used

DIVISION 28 – ELECTRONIC SAFETY AND SECURITY

Not Used

DIVISION 31 – EARTHWORK

Section 311000 Site Clearing

Tacoma, WA

90% Design Submittal

Section 312000 Earth Moving
Section 312300 Excavation and Fill
Section 312500 Erosion and Sediment Controls

DIVISION 32 – EXTERIOR IMPROVEMENTS

Section 321216 Asphalt Paving
Section 321313 Concrete Paving
Section 321723 Pavement Markings

DIVISION 33 - UTILITIES

Not Used

END OF SECTION

USPS MPF Specification Last Revised: 10/1/2022

SECTION 011000

SUMMARY OF WORK

PART 1 - GENERAL

1.1 SCOPE

- A. The Contractor must provide all material, labor, tools, plant, supplies, equipment, transportation, superintendence, temporary construction of every nature, and all other services and facilities necessary to complete the construction of a postal facility for the United States Postal Service (USPS), including all incidental work described in the contract documents.
- B. Scope Includes:
1. Electrical Upgrades for Charger Installation
 - a. Facility electrical will be upgraded to accommodate two (2) Rexel USA Inc/Chargepoint CP6011B-80A-L7 single port, pedestal, 16.6kW chargers with a 23' cable length. Electrical Vehicle Supply Equipment (EVSE) USPS Kit Number CP001.
 - b. To support the facilities electrical requirements, no new transformers or electric panels will be installed.
 - c. Chargers will be placed as shown on the C200 Proposed Conditions drawing. Each charger will be protected by bollards and a concrete wheel stop per the plans.
 2. Lift Replacement/Installation
 - a. No vehicle lifts will be installed through this project scope of work.
 3. Door Replacement/Installation
 - a. Seven (7) overhead doors (Bays 1-7) will be replaced with coiling doors through this project scope of work. Refer to drawings for additional overhead door details.
 - b. No new egress doors will be installed through this project scope of work.
 4. Light Emitting Diode (LED) Lighting
 - a. Interior and exterior lighting will be updated to LED fixtures through this project scope of work. See drawing E100 Electrical Power & Lighting and the Electrical Schedule E401 for details.
 5. Interior Finish Renovation
 - a. The vehicle service area walls will be painted (P-1) white, ceiling paint will remain and interior doors will be painted (P-6) medium gray as noted per plans. See Sheets A001 and A100 for additional room finish details. Ducting, lighting, and/or mechanical will be adjusted to accommodate the required **16'-3" 45'-3"** lift clearance. The service bay flooring will be addressed through application of new epoxy surface coating.
 6. Exterior finish renovation
 - a. The exterior walls will be power washed. Trim and doors will be painted as noted in plans.
 7. Lot Upgrades
 - a. Updates in the parking lot will include filling sizable cracks and the Vehicle Maintenance Facility (VMF) lot will be restriped to accommodate parking for **47 16** employee vehicles and 18 Next Generation Delivery Vehicles (NGDV's). Striping will include repainting bollards, curbs, and road markings.

- C. All work shall be in accordance with applicable codes and local regulations that may apply. In case of conflict in or between the Contract Documents and a governing code or ordinance, the more stringent standard shall apply.

1.2 POSTAL SERVICE FURNISHED – CONTRACTOR INSTALLED EQUIPMENT

- A. The Postal Service will furnish to the Contractor the equipment to be incorporated or installed in the work as identified in the Scope, Specifications, and/or drawings.
- B. The Contractor will complete the Postal Service Furnished – Contractor Installed Equipment form found in Attachment A., identifying quantities and desired delivery dates.
- C. Scheduling and installation must be in accordance with the terms and conditions of the contract provisions and clauses, including those concerning *Postal Service Property*.

1.3 MISCELLANEOUS CONTRACT EXPENSES

- A. In accordance with the terms and conditions of the contract provisions and clauses, including those concerning *Permits and Responsibilities* and, *Building Codes, Fees and Charges*, the Contractor must include in its price proposal a separate line item for the cost each of the of the following fees or charges payable to State, local, or special community development agencies:

Water service connection and meter fee	
Electrical company required fees	
Telephone company required fees	
Off-site inspection fees	
Sanitary sewer connection fee	
Environmental Permits/Registrations	
Other permits or fees	

- B. If the actual cost of any item identified above is more or less than the amount listed, the contract price will be adjusted accordingly by a contract modification. The adjustment will not include overhead and profit. The Contractor must, within 30 days after incurring the expenses, inform the Contracting Officer that the payment has been made. Evidence of the actual amount paid must be provided. The contract amount will be adjusted upward or downward as necessary to accommodate actual charges from the utilities. The Contractor must provide all coordination with the utilities in accomplishing their work and must make all payments to the utilities for their work.
- C. The Contractor must include all additional fees, as required, in the price proposal.

1.4 USPS DIRECT VENDOR EQUIPMENT OR SUPPLIES

- A. In accordance with the terms and conditions of the contract provisions and clauses, including those concerning, *Direct Vendor / Pre-selected Sources*, the Contractor is solely responsible for contracting with the Direct Vendor and ordering, payment, receiving, accepting, storage and installation of United States Postal Service Direct Vendor equipment or supplies. Ordering instructions are included in each specification section.
- B. The Contractor will off-load, inspect the delivered equipment or supplies to make sure they are in good condition, acknowledge receipt, and accept the delivered goods.
- C. Direct Vendor items in this contract are limited to specific items, as shown in the drawings and listed below:
 - 1. Section 083614 - Sectional Knockout Doors
 - 2. Section 083800 - Traffic Doors
 - 3. Section 101404 - Postal Signage

1.5 USPS PRE-APPROVED VENDOR EQUIPMENT OR SUPPLIES

- A. The Contractor is solely responsible for contracting with the Pre-Approved Vendor and ordering, payment, receiving, accepting, storage and installation of United States Postal Service Pre-Approved Vendor equipment or supplies. Ordering instructions are included in each specification section.
- B. The Contractor will off-load, inspect the delivered equipment or supplies to make sure they are in good condition, acknowledge receipt, and accept the delivered goods.

1.6 MISCELLANEOUS EQUIPMENT CROSS-REFERENCE LIST

- A. The following table is a cross-reference for equipment that may be shown in the drawings. The Contractor is responsible for coordinating required delivery date with WSP for Owner Furnished Contractor Installed chargers one month prior to required site delivery date. Contractor is solely responsible for receiving, accepting, storage and installation of the equipment or supplies as specified in each specification section. Contractor is required to coordinate with USPS commissioning agent. USPS Standards for Facility Accessibility Handbook RE-4 supersedes standards in question of conflict.

Postal Service Furnished – Contractor Installed Equipment					
Equipment Number	Postal Stock Number (PSN)/eBuy2 Mfr Part No.	Description	Quantity	Desired Delivery Dates	
				After	Before
		Chargepoint CP6011B Single Port Charger			

The Contractor is responsible for assembling and installing this equipment. Note that certain equipment not listed above, such as security containers, carrier cases and mail processing equipment, may be furnished and installed by USPS. Guidance may be requested from the contracting officer.

PART 2 – PRODUCTS

NOT USED

PART 3 – EXECUTION

NOT USED

END OF SECTION

USPS Specification Last Revised: 10/1/2022

SECTION 011104

CONTRACT DOCUMENTS

PART 1 – GENERAL

1.1 SUMMARY

- A. The contract documents consist of the items included, or attached and incorporated by reference, in Section B, The Contract, B. 1500, *Attachments*.

1.2 DRAWING LIST

- A. The contract drawings consist of the items included, or attached and incorporated by reference, in Section B, The Contract, B. 1500, *Attachments*.

PART 2 – PRODUCTS

NOT USED

PART 3 – EXECUTION

NOT USED

END OF SECTION

USPS Specification Last Revised: 10/1/2022

SECTION 013200

CONSTRUCTION PROGRESS DOCUMENTATION

PART 1 – GENERAL

1.1 SCHEDULING WORK

- A. Before any of the work is started, the Contractor must confer with the COR and agree on a sequence of procedures: means of access to premises and building; delivery of materials and use of approaches; use of corridors, stairways, elevators, and similar means of communication; and the location of partitions, eating spaces for Contractor's employees, and the like.
- B. No work can be done during the holiday mailing season between November 15 and January 5 without written permission from the COR.

1.2 CONSTRUCTION PROGRESS CHART

- A. In accordance with the terms and conditions of the contract provisions and clauses, including those concerning *Construction Progress Chart*, prepare and submit a progress chart within five (5) days after receipt of the Notice to Proceed to show the principal categories of work corresponding with those used in the Schedule of Values:
 - 1. The order in which the Contractor proposes to carry on the work.
 - 2. The date on which it will start each category of work.
 - 3. The contemplated dates for completion.
- B. The chart must be in suitable scale to indicate graphically the total percentage of work scheduled to be in place at any time. At intervals as directed by the COR the Contractor must:
 - 1. Adjust the chart to reflect any changes in the contract work.
 - 2. Enter on the chart the total percentage of work actually in place.
 - 3. Submit six (6) copies of the chart to the Contracting Officer or their designated representative.

1.3 CONTRACTOR-PREPARED NETWORK ANALYSIS SYSTEM

- A. Prepare a Network Analysis System in accordance with the terms and conditions of the contract provisions and clauses concerning *Network Analysis System and Update*, to include, at a minimum, the elements described below. In preparation of this system, the scheduling of construction is the responsibility of the Contractor. The requirement for the system is included to ensure adequate planning and execution of the work and to assist the COR in appraising the reasonableness of the proposed schedule and evaluating progress of the work. The system must consist of diagrams and accompanying mathematical analyses.
- B. Diagrams must show the order and interdependence of activities and the sequence in which the work is to be done as planned by the Contractor. The basic concept of a network analysis diagram must be followed to show how the start of a given activity is dependent on the completion of preceding activities and its completion restricts the start of the following activities. In all cases, the project completion date must be shown on the diagrams as the latest completion date of all activities.
- C. The detailed network activities must include, in addition to construction activities, the submittal and approval of samples of materials and shop drawings, the procurement of critical materials and equipment, and the fabrication of special materials and equipment and their installation and testing. All activities of the Postal Service that affect progress and dates required by the contract for completion of all or parts of the work must be shown. The activities that compose the following separate buildings and features must be separately identifiable by coding or use of sub-networks or both.

<u>Building or Feature</u>	<u>Minimum Number of Activities</u>
Mail Processing Facility	250
Customer Service Facility	100
Site Work	70
Mechanization.....	50
Vehicle Maintenance Facility	40

- D. The selection and number of activities are subject to the COR's approval. Detailed networks must be drafted to show a continuous flow from left to right, with no arrows from right to left. The following information must be shown on the diagram for each activity, preceding the following event numbers: description of the activity, cost, activity duration, and workforce requirements in workdays.

- E. A summary bar chart must be provided on a 30-inch x 42-inch sheet, consisting of a minimum of 30 activities and based on and supported by detailed diagrams. The summary bar chart must be time-scaled, using units of approximately one-half inch to equal 1 week, or other suitable scale approved by the COR. Weekends and holidays must be indicated.

- F. **Mathematical Analysis**
 - 1. The mathematical analysis of the network diagram must include a tabulation of each activity. The following information must be furnished as a minimum for each activity:
 - a. Numbers of preceding and following events.
 - b. Activity description.
 - c. Estimated duration of activities in days.
 - d. Earliest finish date.
 - e. Actual start date.
 - f. Actual finish date.
 - g. Latest start date.
 - h. Latest finish date.
 - i. Slack or float.
 - j. Monetary value of activity, with a labor and material cost breakdown.
 - k. Percentage of activity completed.
 - l. Contractor's earnings based on the portion of activity completed.
 - m. Workforce requirements in workdays.

 - 2. The program or means used in making the mathematical computation must be capable of compiling the total value of completed and partially completed activities and subtotals from separate buildings or features.

 - 3. The analysis must list the activities in sorts or groups as follows:
 - a. By the preceding event number, from lowest to highest, then in the order of the following event number.
 - b. By the amount of slack, then in order of preceding event number.
 - c. By responsibility in order of earliest allowance start date.
 - d. In order of latest allowable start dates, then in order of preceding event numbers, then in order of succeeding even numbers.

- G. **Submission and approval of the system must be as follows:**
 - 1. A preliminary network defining the Contractor's planned operations during the first 90 days after receipt of a Notice to Proceed must be submitted at the preconstruction conference after receipt of a Notice to Proceed.
 - 2. The complete network analysis, consisting of the detailed network mathematical analysis, schedule of anticipated earnings as of the last day of each month, and network diagrams, must be submitted within 30 days after receipt of Notice to Proceed.

- H. **Submission and approval of the system must be as follows:**
 - 1. A preliminary network defining the Contractor's planned operations must be submitted at the preconstruction conference after receipt of a Notice to Proceed.

2. The complete network analysis must be submitted within 30 days after receipt of Notice to Proceed.
 - I. The Contractor must participate in a review and evaluation of the proposed network diagrams and analysis by the COR. Any revisions necessary as a result of this review must be resubmitted for approval of the COR within ten calendar days after the conference. The approved schedule must then be the schedule to be used by the Contractor for planning, organizing, and directing the work, reporting progress, and requesting payment for work accomplished. Thereafter, if the Contractor desires to make changes in its method of operating and scheduling, the Contractor must notify the COR in writing stating the reasons for the change. If the COR considers these changes to be major, the COR may require the Contractor to revise and submit for approval, without additional cost to the Postal Service, all of the affected portions of the detailed diagrams and mathematical analysis to show the effect on the entire project. A change may be considered major if the time estimated to be required or actually used for an activity, or the logic of the sequence of activities varies from the original plan to a degree that there is a reasonable doubt as to its effect on contract completion dates. Changes that affect activities with adequate slack time must be considered minor, except that an accumulation of minor changes may be considered a major change when their cumulative effect might affect the contract completion date.
 - J. The Contractor must submit at monthly intervals a report of actual construction progress by updating the mathematical analysis. Entering updated information into the mathematical analysis is subject to the approval of the COR.
 - K. The report must show the activities or portion of activities completed during the reporting period and their total value as a basis for the Contractor's periodic request for payment. Payments made under the terms and conditions of the contract provisions and clauses, including those concerning *Payment (Construction)*, must be based on the total value of the activities or of partially completed activities after verification by the COR. The report must state the percentage of the work actually completed and scheduled on the report date and the progress along the critical path in terms of days ahead or behind the allowable dates. If the project is behind schedule, progress along other paths with negative slack must also be reported. The Contractor must also submit a narrative report with the updated analysis, which must include, but is not limited to, a description of the problem areas, current and anticipated delaying factors and their impact, and an explanation of corrective actions taken or proposed.
 - L. The sheet size of diagrams must be 30 inches x 42 inches. Each updated copy must show the date of the latest revision.
 - M. Initial submittal and complete revisions must be submitted in three copies.
 - N. Periodic reports must be submitted in two copies.
 - O. Network analysis system revisions occurring as a result of modifications or changes in the work must be in accordance with the terms and conditions of the contract provisions and clauses, including those concerning *Network Analysis Systems and Update*.
 - P. Float or slack is defined as the amount of time between the early start date and the late start date of any of the activities in the network analysis system schedule. Float or slack time is not time for the exclusive use or benefit of either the Postal Service or the Contractor. Extensions of time for performance required under the terms and conditions of the contract provisions and clauses, including those concerning *Changes; Differing Site Conditions; Termination for Convenience or Default; Excusable Delays; or Suspensions and Delays* may be granted only to the extent that equitable time adjustments for the activity or activities affected exceed the total float or slack along the channels involved at the time that Notice to Proceed was issued for the change.

PART 2 – PRODUCTS

NOT USED

PART 3 – EXECUTION

NOT USED

END OF SECTION

USPS Specification Last Revised: 10/1/2022

SECTION 013300
SUBMITTAL PROCEDURES

PART 1 – GENERAL

1.1 SCHEDULE OF SUBMITTALS

- A. In accordance with the terms and conditions of the contract provisions and clauses, including those concerning Shop Drawings, Coordination Drawings, *Record "As Built" Drawings, and Schedules*; within 30 days after receiving a Notice to Proceed, the Contractor must complete the Schedule of Submittals, in the format indicated below, in duplicate, listing all items that must be furnished for review and approval by the Postal Service. The schedule must indicate the type of items (such as sample, shop drawings, catalog cut, and so forth) and include the scheduled dates of submittal. In preparing the schedule, adequate time (10 business days or more, exclusive of time in the mails) must be allowed for review and approval and possible resubmittal. Also, the schedule must be coordinated with the approved construction progress chart. The Contractor must revise and/or update the schedule as directed. Such revised schedules must be made available to the COR for monitoring.
- B. Within 30 days after receiving a Notice to Proceed, the Contractor must complete and submit to the COR a listing of all subcontractors, including subcontractor name, address, telephone number, fax number and email address. Include an updated list with each progress payment request.
- C. Schedule of Submittals Format

Project _____

Contract No. _____

Project Description _____

Spec. Section	Spec. Description	Paragraph Number	*Submittal Type	Date		Action Taken	Assigned Number
				Submittal	Returned		

*Submittal Type:

C – Certificate	CD – Catalog Data
S – Sample	PL – Spare Parts List
SD – Shop Drawing	MM – Maintenance Manual

1.2 SHOP DRAWINGS AND RELATED DATA

- A. Submittal of shop drawings, samples and related data must conform to the requirements of the terms and conditions of the contract provisions and clauses, including those concerning, *Record "As Built" Drawings, and Samples*. Prior to submittal, the Contractor must stamp the submittal to indicate that it has been reviewed and approved. The Contractor must make any corrections required by the COR. If the Contractor considers any correction indicated on the drawings to constitute a change to the contract drawings or specifications, notice, as required under the terms and conditions of the contract provisions and clauses, including those concerning Changes must be given to the COR. [Four] [] prints of all

approved shop drawings must be given to the COR. The approval of the drawings by the COR must not be construed as a complete check but indicates only that the general method of construction and detailing is satisfactory. Approval of the shop drawings does not relieve the Contractor of responsibility for any error that may exist because the Contractor is responsible for the dimensions and design of adequate connections and details and for satisfactory construction of all work. The submission by the Contractor must be accompanied by a transmittal letter of a type approved by the COR.

1. Each shop drawing must have a blank area of 5 by 5 inches, located adjacent to the title block. The title block must display:
 - a. Number and title of drawing;
 - b. Date of drawing or revision;
 - c. Name of project building or facility;
 - d. Name of Contractor and (if appropriate) of subcontractor submitting drawing;
 - e. Clear identity of contents and location on the work; and
 - f. Project title and contract number.
2. All drawings to be provided shall be clear and fully representative of the facility and fixed mechanization work.
3. Drawing files to be in .dwg and .pdf formats. .dwg files to be generated from Autocad revision 12 or other revision level concurred by USPS.
4. Documents other than drawings shall be provided in MicroSoft Word format.
5. Interim project documentation may provide to USPS electronically
6. All final project documentation shall be provided to the USPS on a single CD or DVD media

1.3 EQUIPMENT ROOM LAYOUT DRAWINGS

- A. The Contractor must prepare and submit equipment room layout drawings as required by the technical provisions as well as for areas where equipment proposed for use could present interface or space difficulties. Room layout drawings must be submitted within 40 days after receiving a Notice to Proceed and must conform to the specified requirements for shop drawings. Submittals describing the various mechanical and electrical equipment items that are to be installed in the areas represented by the layout drawings must be assembled and submitted concurrently and must be accompanied by the room layout drawings. Room layout drawings must be consolidated for all trades, to scale, and must show all pertinent structural and fenestration features and other items, such as cabinets, that are required for installation and that affect the available space. All mechanical and electrical equipment and accessories must be shown to scale in the plan and also in elevation or section in their installation positions. Ductwork and piping must be shown.

1.4 MATERIAL, EQUIPMENT, AND FIXTURE LISTS

- A. When required by the technical provisions, lists of materials, equipment, and fixtures must be submitted by the Contractor in accordance with the requirements specified for shop drawings. The lists must be supported by sufficient descriptive material, such as catalogs, cuts, diagrams, and other data published by the manufacturer, as well as by evidence of compliance with safety and performance standards, to demonstrate conformance to the specification requirements. Catalog numbers alone are not acceptable. The data must include the name and address of the nearest service and maintenance organization that regularly stocks repair parts. No consideration will be given to partial lists submitted from time to time. Approval of materials and equipment is tentative, subject to submission of complete shop drawings indicating compliance with the contract documents.

1.5 CERTIFICATES OF COMPLIANCE

- A. Any certificates required for demonstrating proof of compliance of materials with specification requirements, including mail certificates, statements of application, and extended guarantees, must be signed and submitted 4 copies to the COR at least 10 days before delivery. The Contractor must review all certificates before submissions are made to the COR, to ensure compliance with the contract

specification requirements and to ensure that the affidavit is properly signed. Each certificate must be signed by an official authorized to certify on behalf of the manufacturing company and must contain the name and address of the Contractor, the project name and location, and the quantity and date or dates of shipment or delivery to which the certificates apply. Copies of laboratory test reports submitted with certificates must contain the name and address of the testing laboratory and the dates of tests to which the report applies. Certification must not be construed as relieving the Contractor from furnishing satisfactory material if, after tests are performed on selected samples, the material is found not to meet the specific requirements.

1.6 A-E'S REVIEW OF SUBMITTALS

- A. When submittals are reviewed by the A-E on behalf of the COR, each submittal must be returned to the Contractor stamped or marked by the A-E in one of the following ways:
 - 1. A Action: The Contractor is advised that "A Action" means that fabrication, manufacture, or construction may proceed, provided the work complies with the contract documents.
 - 2. B Action: The Contractor is advised that "B Action" means that fabrication, manufacture, or construction may proceed, provided the work complies with the A-E's notations and the contract documents.
 - 3. C Action: The Contractor is advised that "C Action" means that no work may be fabricated, manufactured, or constructed and that the Contractor must make a new submittal to the A-E. Any submission marked "C Action" is not permitted on the site.
- B. The A-E must return reproducibles stamped "A Action" or "B Action" to the Contractor, who is responsible for obtaining prints of them and for distributing them to the field and to subcontractors.
- C. In the case of shop drawings in the form of manufacturers' descriptive literature, catalog cuts, and brochures stamped "A Action" or "B Action," the A-E must return the stamped copies to the Contractor, who is responsible for distributing them to the field and to the subcontractors. If the shop drawings are stamped "C Action," the A-E will return stamped copies to the Contractor, who must submit new shop drawings to the A-E.
- D. In the case of samples stamped "A Action" or "B Action," the A-E must return one of the samples to the Contractor. In the case of samples stamped "C Action," the A-E must return all of the submitted samples.

1.7 SPARE PARTS DATA

- A. Spare parts data must be submitted in quadruplicate in accordance with the terms and conditions of the contract provisions and clauses, including those concerning *Spare Parts Data*.

1.8 SCHEDULE OF VALUES

- A. In accordance with the terms and conditions of the contract provisions and clauses concerning, *Construction Cost Breakdown*, the Contractor must submit a construction cost breakdown using the attached Schedule of Values.
- B. Submit the construction cost breakdown after contract award to the COR. A Sample Schedule of Values and Definitions is attached to this Section, as Attachment A.
- C. Do not delete items from the Schedule of Values form. The number of items provided on the Schedule of Values form are the minimum required; additional subdivision of these items may be provided by the Contractor.

- D. If the contract price changes, the Schedule of Values must be revised to reflect the change(s) and forwarded to the COR.
- E. A current Schedule of Values must accompany all Contractor Requests for Payment.

1.9 FIXED MECHANIZATION CONSTRUCTION COST ESTIMATE BREAKDOWN SUMMARY

- A. In accordance with the terms and conditions of the contract provisions and clauses concerning, *Construction Cost Breakdown*, the Contractor must submit a construction cost estimate using the Fixed Mechanization Construction Cost Estimate Breakdown Summary indicated below. When applicable, a separate cost estimate breakdown form must be submitted for each separate building. The number of items provided on the form are the minimum required. Additional subdivision of these items may be used by the Contractor.
- B. Submit the Fixed Mechanization Construction Cost Estimate Breakdown Summary after contract award to the COR.

PART 2 – PRODUCTS

NOT USED

PART 3 – EXECUTION

NOT USED

Fixed Mechanization Construction Cost Estimate Breakdown Summary

Project _____ Location _____
 General _____
 Contractor _____
 Mechanization _____
 Contractor _____
 Date _____ Prepared by _____ Checked by _____

1. Bulk Conveyors	Designation	Cost	Designation	Cost	
	_____	_____	_____	_____	
	_____	_____	_____	_____	
	_____	_____	_____	_____	
<i>Subtotal</i>					
			Quantity	Length (ft.)	
3. Extendable Conveyors (loading)			_____	_____	_____
4. Extendable Conveyors (unloading)			_____	_____	_____
5. Sack Sorting Machine (belt)			_____	_____	_____
6. Sack Sorting Machine (over and under)			_____	_____	_____
7. Sack Sorting Machine (carousel)			_____	_____	_____
8. Multi-Slide Sorter (sacks)			_____	_____	_____
9. Multi-Slide Sorter (parcels)			_____	_____	_____
11. Sawtooth Platforms	Designation	Cost	Designation	Cost	
	_____	_____	_____	_____	
	_____	_____	_____	_____	
	_____	_____	_____	_____	
Other					_____
<i>Subtotal</i>					_____

		Cost	Quantity (Total)	Length	
10. Tray Conveyors					
MPR (24VDC)		_____	_____	_____	
Spirals All, (Up/DWN)		_____	_____	_____	
Belt		_____	_____	_____	
Diverging and Converging		_____	_____	_____	
Gravity		_____	_____	_____	
LCTS		_____	_____	_____	
HSTS		_____	_____	_____	
Other		_____	_____	_____	
<i>Subtotal</i>					_____
12. Other		_____	_____	_____	
<i>Subtotal</i>					_____
<i>Total Fixed Mechanization Cost</i>					_____

END OF SECTION

013300 - 5

USPS Specification Last Revised: 10/1/2022



Schedule of Values

Facility:
Contractor:
Date:

Item	Description of Work	Scheduled Value	Work Completed					Work Remaining	
			Previous Application	This Application		Total Completed and Stored	%	Balance to Finish	Retainage
				Work In Place	Stored Materials				
Division 01	General Conditions	%							
	1.0 Overhead								
	1.1 Profit								
	1.2 Bonds & Insurance								
	1.3 Bldg. Permits								
	1.4 O. & M. manuals								
	1.5 Training								
	1.6 Subtotal, % only		-	-	-	-	-	-	-
Division 02	Existing Conditions								
	2.0 Demolition								
Division 03	Concrete								
	3.0 Site Concrete								
	3.1 Building Concrete								
Division 04	Masonry								
	4.0 Masonry								
Division 05	Metals								
	5.0 Structural Steel								
	5.1 Steel Joists								
	5.2 Steel Deck								
	5.3 Metal Studs								
	5.4 Handrails & Railings								
Division 06	Wood, Plastics and Composites								
	6.0 Rough Carpentry								
	6.1 Finish Carpentry								
Division 07	Thermal & Moisture Protection								
	7.0 Roofing System								
	7.1 Wall Insulation & V.B.								
Division 08	Openings								
	8.0 Doors & Frames								
	8.1 Specialty & Grilles								
	8.2 Impact Traffic Doors								
	8.3 Storefronts								
	8.4 Hardware								
	8.5 Other Glazing								
	8.6 Sectional Knockout Doors								
Division 09	Finishes								
	9.0 Gypsum Board								
	9.1 Tile								
	9.2 Acoustical Ceiling								
	9.3 Resilient & Carpet								
	9.4 Painting								
Division 10	Specialties								
	10.0 Toilet Accessories								
	10.1 Flagpoles								
	10.2 Exterior Signage								
	10.3 Interior Signage								
	10.4 Lockers								
	10.5 Wall and Door Protection								
	10.6 Toilet Compartment								
Division 11	Equipment								
	11.0 Dock Equipment								
	11.1 Food Service Equipment								
Division 12	Furnishings								
	12.0 Casework								

Item	Description of Work	Scheduled Value	Work Completed					Work Remaining			
			Previous Application	This Application		Total Completed and Stored	%	Balance to Finish	Retainage		
				Work In Place	Stored Materials						
Division 13	Special Construction										
13.0	Metal Building Systems										
13.2	Vaults										
Division 14	Conveying Equipment										
Division 21	Fire Suppression										
21.0	Fire Sprinkler System										
Division 22	Plumbing										
22.0	Plumbing										
Division 23	Heating Ventilating and Air Conditioning										
23.0	Duct Cleaning										
23.1	Air Handling Units										
23.2	Heating & Ventilation Units										
23.3	HVAC Pumps										
23.4	VAV Terminal Units										
23.5	Rooftop Units										
23.6	VRV Systems										
23.7	Unit Heaters										
23.8	Chillers										
23.9	Cooling Towers										
23.10	Water Treatment										
23.11	Controls Systems										
23.12	Ductwork and Duct Insulation										
23.13	HVAC Piping & Insulation										
23.14	Testing & Balancing, & Commissioning Assistance										
Division 25	Integrated Automation										
25.0	Building Automation System										
25.1	EEMS Integration										
Division 26	Electrical										
26.0	Electrical Power										
26.1	Electrical Lighting										
Division 27	Communications										
27.0	Communications Systems										
Division 28	Electronic Safety and Security										
28.0	IDS System										
28.1	Robbery Countermeasure CCTV										
28.2	Investigative CCTV										
28.3	Physical Access Control System (PACS)										
28.4	Fire Alarm System										
28.5	Security CCTV										
Division 31	Earthwork										
31.0	Site Clearing										
31.1	Earthwork (develop.)										
31.2	Earthwork (finish)										
Division 32	Exterior Improvements										
32.0	Paving (off-site)										
32.1	Paving										
32.2	Chain Link Fence & Gates										
32.3	Landscaping										
Division 33	Utilities										
33.0	Utilities & Fees (off-site)										
33.1	Utilities (on-site)										
33.2	Electrical (site)										
	Subtotal		(without General Conditions)								
Subtotal	Site Development		(#2.0, #31.0, #31.1, #32.0 and #33.0) x (100% + #1.7 percentage)								
	Site Improvement		(#3.0, #10.2, #31.2, #32.1, #32.2, #32.3, #33.1 and #33.2) x (100% + #1.7 percentage)								
	Building		(Construction costs not including Sitework cost) x (100% + #1.6 percentage)								
	Total	\$	-	\$	-	\$	-	\$	-	\$	-

Facility:

FSM Project Number:

Contractor:

Date:

Item	Description of Work	Material	Labor	Total
Division 01	General Conditions			
1.1	Overhead			\$ -
1.2	Profit			\$ -
1.3	Bldg. Permits			\$ -
1.4	Testing			\$ -
1.5	Other			\$ -
Division 02	Existing Conditions			
2.1	Demolition			\$ -
Division 03	Concrete			
3.1	Site Concrete			\$ -
3.2	Building Concrete			\$ -
3.3	Other			\$ -
Division 04	Masonry			
4.1	Masonry			\$ -
Division 05	Metals			
5.1	Structural Steel			\$ -
5.1	Other			\$ -
Division 06	Wood, Plastics and Composites			
6.1	Carpentry			\$ -
6.2	Other			\$ -
Division 07	Thermal & Moisture Protection			
7.1	Roofing System			\$ -
7.2	Wall Insulation & V.B.			\$ -
7.3	Other			\$ -
Division 08	Openings			
8.1	Doors & Frames			\$ -
8.2	Specialty Doors			\$ -
8.3	Windows			\$ -
8.4	Other			\$ -
Division 09	Finishes			
9.1	Floors			\$ -
9.2	Walls			\$ -
9.3	Ceilings			\$ -
9.4	Painting			\$ -
Division 10	Specialties			
10.1	Signage			\$ -
10.2	Other			\$ -
Division 11	Equipment			
11.1	Dock Equipment			\$ -
11.2	Other			\$ -
Division 12	Furnishings			
12.1	Casework			\$ -
12.2	Other			\$ -
Division 13	Special Construction			
13.0	Metal Building Systems			\$ -
13.2	Vaults			\$ -
13.3	Other			\$ -
Division 21	Fire Suppression			
21.0	Fire Sprinkler System			\$ -
Division 22	Plumbing			
22.0	Plumbing			\$ -

Item	Description of Work	Material	Labor	Total
Division 23	Heating Ventilating and Air Conditioning			
23.0	Duct Cleaning			\$ -
23.1	Air Handling Units			\$ -
23.2	Heating & Ventilation Units			\$ -
23.3	HVAC Pumps			\$ -
23.4	VAV Terminal Units			\$ -
23.5	Rooftop Units			\$ -
23.6	VRV Systems			\$ -
23.7	Unit Heaters			\$ -
23.8	Chillers			\$ -
23.9	Cooling Towers			\$ -
23.10	Water Treatment			\$ -
23.11	Controls Systems			\$ -
23.12	Ductwork and Duct Insulation			\$ -
23.13	HVAC Piping & Insulation			\$ -
23.14	Testing & Balancing, & Commissioning Assistance			\$ -
Division 25	Integrated Automation			
25.0	Building Automation System			\$ -
25.1	EEMS Integration			\$ -
Division 26	Electrical			
16.0	Electrical Power			\$ -
16.1	Electrical Lighting			\$ -
16.2	Structured Wiring			\$ -
16.3	Other			\$ -
Division 27	Communications			
27.0	Communications Systems			\$ -
Division 28	Electronic Safety and Security			
28.0	IDS System			\$ -
28.1	Robbery Countermeasure CCTV			\$ -
28.2	Investigative CCTV			\$ -
28.3	EAS System			\$ -
28.4	Fire Alarm System			\$ -
Division 31	Earthwork			
31.0	Earthwork			\$ -
Division 32	Exterior Improvements			
32.0	Paving			\$ -
32.1	Landscaping			\$ -
	Total	\$ -	\$ -	\$ -

Schedule of Values

Facility:
 FSM Project Number:
 Contractor:
 Date:

Item	Description of Work	Material	Labor	Total
Division 01	General Requirements			
1.1	Mobilization and Demobilization			\$ -
1.2	Interior Protection			\$ -
1.3	Taxes, Permits, Misc. Fees			\$ -
1.4	Bonds			\$ -
1.5	Allowance			\$ -
1.6	Contractor 2-Year Guarantee			\$ -
1.7	[other]			\$ -
Division 02	Existing Conditions			
2.1	Existing Roof Removal and Disposal			\$ -
2.2	Substrate Preparation Work			\$ -
2.3	Steel and Wood Deck Re-securement			\$ -
2.4	Removal and Disposal of Non-Friable ACM			\$ -
2.5	[other]			\$ -
Division 03	Concrete			
3.1	[other]			\$ -
Division 04	Masonry			
4.1	Masonry Repair			\$ -
4.2	[other]			\$ -
Division 05	Metals			
5.1	[other]			\$ -
Division 06	Wood, Plastics, and Composites			
6.1	Wood Blocking, Nailers, and Plywood			\$ -
6.2	[other]			\$ -
Division 07	Thermal and Moisture Protection			
7.1	Roofing Repairs			\$ -
7.2	Underlayment			\$ -
7.3	Roof Insulation and Cover Board			\$ -
7.4	Roofing Membrane, Flashing & Accessories			\$ -
7.5	Sheet Metal Flashing			\$ -
7.6	Sealant			\$ -
7.7	[other]			\$ -
Division 09	Finishes			
9.1	Painting			\$ -
9.2	Interior Ceiling Tile Replacement			\$ -
9.3	[other]			\$ -
Division 22	Plumbing			
22.1	Miscellaneous Plumbing Work			\$ -
22.2	[other]			\$ -
Division 23	Heating, Ventilating, and Air Conditioning			
23.1	Misc. HVAC Equipment and Ductwork Work			\$ -
23.2	[other]			\$ -
Division 26	Electrical			
26.1	Miscellaneous Electrical Work			\$ -
26.2	LP Displacement, Re-installation & Re-certification			\$ -
26.3	[other]			\$ -
Division 28	Electronic Safety and Security			
28.1	Security System/Fire Alarm System Work			\$ -
28.2	[other]			\$ -
	Total	\$	- \$	\$ -



Schedule of Values Definitions

Facility:	Facility name and state.
Contractor:	General Contracting company name.
Paving (off-site) #32.0:	Off-site improvements such as streets.
Utilities (off-site) #33.0:	Off-site utility improvements, relocation of utilities and site fees.
Earthwork (develop.) #31.1:	Rough grading, removal of unsuitable material and importation of fill.
Earthwork (finish) #31.2:	Storm water systems, septic systems and finish grading.
Electrical (site) #33.3:	Site lighting and related electrical work.
Paving #32.1:	Asphalt and concrete paving and striping.
Exterior signage #10.2:	Exterior and building mounted signage.
Landscaping #32.3:	Soil treatment, landscaping and irrigation systems.
Site Concrete #3.0:	Curbs and gutters, sidewalks, site pilings and retaining walls.
Building Concrete #3.1:	Foundations, building pilings, slab-on-grade, cast-in-place and precast concrete.
Site Development:	Site construction costs that make the site usable and increase the value for the Postal Service and subsequent users. The prorated portion of General Conditions is included. This includes: Paving (off-site) #32.0, Utilities (off-site) #2.1, Site Clearing #31.0, Demolition #2.0 and Earthwork (development) #31.1
Site Improvement:	Site construction costs that are necessary for the construction of the project, but do not necessarily increase the value of the site for subsequent users. The prorated portion of General Conditions is included. This includes: Earthwork (finish) #31.2, Utilities (on-site) #33.1, Electrical (site) #33.2, Paving #32.1, Exterior signage #10.2, Fences & Gates #32.2, Landscaping #32.3 and Site Concrete #3.0
Building Cost:	Construction costs that do not include Sitework costs. The prorated portion of General Conditions is included.

SECTION 013543

ENVIRONMENTAL PROCEDURES

PART 1 – GENERAL

1.1 SCOPE

- A. This section is required in accordance with the terms and conditions of the contract provisions and clauses, including those concerning Safety & Health Standards, Accident Prevention, Protection of the Environment, Existing Vegetation, Structures, Utilities and Improvements, and Handling Asbestos and other Hazardous Materials. The work covered by this section consists of furnishing all labor, material, and equipment and performing all work required for compliance with environmental regulations and preventing pollution during, and as a result of, construction operations under this contract, in addition to those measures set forth in other technical provisions of these specifications.
- B. The Contractor and subcontractors must comply with all applicable federal, state and local laws and regulations related to the environment, health and safety.

1.2 NOTIFICATION

- A. The Contractor must, after receiving a notice of noncompliance with the foregoing provisions, immediately take corrective action. The notice, when delivered to its Contractor or its authorized representative at the site of the work, is deemed sufficient for this purpose. If the Contractor fails or refuses to comply promptly, the Contracting Officer may issue an order stopping all or part of the work until satisfactory corrective action has been taken. No part of the time lost because of any such stop orders may be made the subject of a claim for extension of time or for excess costs or damages by the Contractor unless it is subsequently determined that the Contractor was in compliance and the Contractor demonstrates that it is otherwise entitled to an extension of time, excess costs or damages, under the applicable terms and conditions of the contract provisions and clauses.

1.3 ENVIRONMENTAL REGULATORY COMPLIANCE

- A. Within 30 days after receiving the notice to proceed or not less than 15 days prior to commencing on-site work, the Contractor must submit any environmental documents that are required by federal, state or local environmental regulations. Plans must be approved by the COR prior to commencing on-site work and must describe and include, but is not limited to, the following
 1. Erosion Control and Stormwater Management Plan that describes erosion control methods, surface drainage, storm water permitting requirements, and if applicable, protection of site wetlands and/or compliance with wetland permits. This must ensure any federal, state or local permitting requirements for site preparation, erosion control or surface drainage are met.
 2. Landscape Management and Protection Plan that ensures any site-specific beneficial landscaping requirements are met. The plan shall describe the prevention and restoration of landscape damage, temporary roads and embankments, and post construction cleanup as prescribed in the terms and conditions of the contract provisions and clauses, including those concerning *Protection of the Environment, Existing Vegetation, Structures, Utilities and Improvements*.
 3. Waste Minimization and Management Plan must describe how natural resources potentially impacted by construction will be protected or managed; construction wastes will be stored and disposed of or recycled; and pollutants associated with building materials will be controlled. The waste minimization and management section of the plan must also list materials and construction debris to be recycled, and address the disposal of solid and hazardous wastes and materials, including asbestos and lead-based paint. It

must also include tables applicable to the reclamation of chlorofluorocarbons (CFCs) and hydrochlorofluorocarbons (HCFCs) in accordance with 1.4 (B) below.

4. Environmental Compliance Plan must document NEPA compliance by describing mitigation measures to address environmental concerns/sensitive receptors identified in the National Environmental Policy Act (NEPA) document(s) in Section B. 1500, *Attachments*, of the contract.
5. The construction specifications in this contract must include mitigation measures to avoid or minimize potential environmental impacts identified in the NEPA document(s).

1.4 ENVIRONMENTAL SITE CONTROLS

- A. Location of Hazardous Materials: The location of the Contractor's temporary storage of any hazardous materials and/or wastes must be appropriately marked and included in the health and Safety Plan (see Section 1.5 below).
- B. Refrigerant Recovery, Recycling, and Disposal: Any work involving the replacement or repair of equipment containing refrigerant shall meet the following requirements:
 1. Recover and recycle or dispose of refrigerant from equipment according to 40 CFR 82 and local regulations.
 2. The work shall be completed by a certified refrigerant recovery technician, per 40 CFR 82 and local regulations.
 3. Provide a statement signed by the certified refrigerant recovery technician that the work was completed per 40 CFR 82 and local regulations. Include the name and address of technician and date refrigerant was recovered.
- C. Post-construction Cleanup or Obliteration: The Contractor must remove and properly dispose of all signs of temporary construction facilities such as haul roads, work area, structures, foundations of temporary structures, excess or waste materials, or any other vestiges of construction as directed by the COR. No separate or direct payment may be made for post-construction cleanup and all associated costs must be considered included in the contract price.
- D. Historical and Archeological: Monuments, markers, and works of art must be protected. Items discovered that have potential historical or archeological interest must be preserved. The Contractor must leave the archeological find undisturbed and must immediately report the find to the COR so that the proper authority may be notified.
- E. Dust Control: The Contractor must keep the site free from dust in accordance with applicable federal, state and/or local regulations.
- F. Noise Minimization: The Contractor must perform demolition and construction operations to minimize noise including conducting work during less sensitive hours of the day in accordance with applicable noise control regulations.

1.5 HEALTH AND SAFETY

- A. Prior to commencing on-site work, the Contractor must submit an Occupational Safety and Health Administration (OSHA) Emergency Action Plan (EAP) to the Contracting Officer to demonstrate compliance by the Contractor and subcontractors with applicable OSHA regulations. If the Contractor is not required by OSHA to develop a written EAP, i.e. if 10 or fewer are employed for the construction project or any other specific regulations identified by OSHA, then the Contractor shall submit to the Contracting Officer a signed letter stating the Contractor shall meet OSHA's EAP requirements in a verbal communication to all employees.
- B. The Postal Service has provided a *Safety and Health Guide for Contractors*, as Attachment A to this section. Prior to commencing on-site work, Contractor must read the *Safety and Health Guide for Contractors* and must sign the attached Certificate of Understanding acknowledging and accepting the requirements stated therein.

- C. Prior to commencing on-site work, the Contractor must submit a project-specific Project Safety Plan to the Contracting Officer. The plan must include, but is not limited to, hazard communication, labeling, emergency response and preparedness and training.
- D. Copies of Material Safety Data Sheets (MSDSs) for any hazardous material(s), as defined by OSHA's Hazard Communications Standard, must be included whenever such materials arrive on-site. MSDSs must be kept together and maintained centrally on-site through to project completion. Provide a copy of each MSDS in the Operating and Maintenance Manual. The use of asbestos containing materials, in excess of one percent as defined by US Environmental Protection Agency regulations, is prohibited in the construction of this project. Provide an executed copy of the "Certificate of Asbestos and Lead-Based Paint (New Work)" in the Operating and Maintenance Manual and include a copy with the final payment request.
- E. The use of lead-based paint is prohibited in the construction of this project.
- F. The use of lead-containing solder for plumbing and plumbing fixtures is prohibited in the construction of this project.
- G. In accordance with the terms and conditions of the contract provisions and clauses, including those concerning *Asbestos Free and Lead-Based Paint Free Certification*, the Contractor must sign and submit to the Contracting Officer the attached "Certification of Asbestos and Lead-Based Paint" for this project. The signed certificate is required to be included in the final payment request.
- H. Do not use any of the USPS targeted chemicals (see regulated and prohibited materials identified under Safety and Health and related environmental requirements).

PART 2 - PRODUCTS

NOT USED

PART 3 - EXECUTION

NOT USED

END OF SECTION

USPS Specification Last Revised: 10/1/2022

013543-3

Safety and Health Guide for Contractors

Certificate of Understanding

This *Safety and Health Guide for Contractors* was developed by the Postal Service to provide guidance for contractors hired to perform repair, alteration, renovation, demolition, equipment installation, and other work requiring access to postal-owned or -leased property.

Distribution

A copy of this Certificate of Understanding should be signed by the Contractor's representative at the post award orientation conference or before the commencement of work. A copy of this guide should be readily accessible where the work is being performed. The contracting officer's representative (COR) should thoroughly brief the Contractor's representative on the Contract Safety and Health Requirements contained herein.

Contractor's Verification Statement

As a representative of _____ (Contractor's name), I have received the *Safety and Health Guide for Contractors* prepared by the Postal Service. As the Contractor's representative, I understand and accept the requirements contained herein, and I have reviewed each of the required sections of the guide with the COR and/or the designated Postal Service representative. I agree to review the contents of this guide with all subcontractors hired to perform work on postal property.

Contractor's Representative

Printed Name: _____ Contact Number: _____
Signature: _____ Date: _____

Designated Postal Service Representative

Printed Name: _____ Contact Number: _____
Signature: _____ Date: _____

Safety Representative (If Required by COR)

Printed Name: _____ Contact Number: _____
Signature: _____ Date: _____

Postal Service CO, COR, or Project Manager

Printed Name: _____ Contact Number: _____
Signature: _____ Date: _____

Maintain a copy of this signed form in the Postal Service and Contractor's project files.

Safety and Health and Related Environmental Requirements

The Contractor is required to meet all applicable OSHA, federal, state, and local safety, health, and related environmental requirements in addition to the US Postal Service requirement listed in this table.	
Issue	Postal Requirements
Asbestos	<p><i>Review of Facility Asbestos Survey:</i> Before any building maintenance, equipment installation, renovation, alteration, demolition, or other project begins, determine whether ACBM will be disturbed.</p> <p><i>Proper Work Practices:</i> If ACBM is present, follow proper control procedures and work practices.</p> <p><i>Consultation With Facility Asbestos Coordinator:</i> Consult with the facility manager or his or her designee before the start of any work likely to disturb ACBM. Disturbance means activities that crumble or pulverize ACBM or presumed asbestos-containing material (PACM) or generate visible debris. Operations may include drilling, abrading, cutting a hole, pulling cable, and crawling through tunnels or attics and spaces above the ceiling where asbestos is actively disturbed or asbestos-containing debris is actively disturbed.</p> <p><i>Asbestos Work Authorization:</i> You must have an approved Form 8210, <i>Work Authorization - Asbestos</i>, before work begins within any building containing asbestos.</p>
Barricades, Barriers, and Warnings	Your barricades must meet the OSHA requirements. In addition, you assume control of your work area during your activities unless otherwise specified in writing by the contracting officer (CO) or contracting officer's representative (COR).
Confined Spaces	<p>Confined space work must meet the OSHA requirements. You must have a comprehensive confined space program that includes a written program, employee training, entry and testing equipment, and rescue capabilities.</p> <p>If you require access to confined space requiring a permit, then the trained, designated Postal Service representative must review and approve the project and permit. Entry into other confined spaces must be in accordance with OSHA regulations.</p>
Electrical Work	Lock or rope off work areas involving exposed energized equipment or have an attendant present to prevent accidental contact by unqualified people. Refer to the Barricade section of this guideline for additional information.
Elevated Work and Fall Protection	Follow strictly the applicable OSHA fall protection requirements.
Excavation	<p>All excavations 4 feet or more in depth must be properly shored or sloped and meet all OSHA requirements.</p> <p>Before any digging or drilling commences, inform the Postal Service COR and call Dig Safe or its local equivalent to determine whether any underground utilities are located in the work area. Submit documentation that these notifications have been performed. You must not begin digging or drilling until you have verified that underground utilities have been identified and are properly marked so that work may be accomplished in a safe manner.</p>
Fire Protection	<p>Do not block, remove, or otherwise prevent Postal Service fire extinguishers from being immediately accessible and usable.</p> <p>If a system must be impaired by a scheduled shutdown, notify the appropriate Postal Service representative and do not proceed without Postal Service authorization.</p>
Hazard Communication	<p>Inform the Postal Service before any chemicals are used. Before materials are brought on site, provide material safety data sheets (MSDSs) and an inventory of materials. For projects that are anticipated to use substantial quantities of hazardous materials, you may be required to provide a routing, storage, and waste disposal plan.</p> <p>Upon request, the Postal Service will make available to you MSDSs for hazardous materials the Postal Service uses in the Contractor work area.</p>
Hazardous Materials	<p>Follow all OSHA requirements regarding hazardous materials. Hazardous materials include, but are not limited to, flammable and combustible liquids, gasoline, diesel fuel, motor oil, lubricating oil, hydraulic oil, corrosive cleaners, and battery acid.</p> <p>Provide secondary containment for all containers of liquids that are over 5 gallons in capacity.</p> <p>Immediately report all hazardous material releases ("spills"), regardless of how small or where they occur, to the designated Postal Service representative. Releases include solids, liquids, and gases.</p>
Hot Work	<p>Do not begin any hot work until a Postal Service qualified person has completed and signed a Postal Service Hot Work Permit. The permit will be valid for only a single work shift. You must display the permit at the work site.</p> <p>You are prohibited from performing hot work (a) when the Postal Service has not authorized it, (b) in locations in which fire protection systems have been impaired, (c) in the presence of</p>

	explosive or flammable atmospheres, or (d) in locations where large quantities of flammable and combustible materials are unprotected.
Powered Industrial Trucks	Powered industrial trucks and other mobile equipment must follow all traffic rules of the postal facility. The maximum speed limit for in-plant powered vehicles is 5 miles per hour. Many work areas have posted speed limits that you must strictly follow. Perform refueling only in authorized locations following safe procedures. As a general rule, the Postal Service does not allow gas- or diesel-powered industrial equipment inside postal facilities. Coordinate exceptions to the rule through the servicing safety office.
Ladders	Strictly follow all OSHA requirements regarding ladders. Barricade the ladder use area to prevent contact with mobile equipment and employees.
Lead-Based Paint	<i>Review of Facility Lead Survey:</i> Before any construction, alterations, and/or repair activities begin, determine whether LBP will be disturbed. If the painted surface has not been tested, you must have it tested before beginning any activities that could potentially disturb LBP. <i>Proper Work Practices:</i> If LBP is present, follow proper control procedures and work practices. <i>Consultation With Facility Manager:</i> Consult with the facility manager or his or her designee before the start of any work likely to disturb LBP. Examples of activities that may affect LBP include paint removal by scraping, sanding, power tools, or heat guns; alterations that include removing drywall, structural steel, or other building materials coated with LBP; welding, cutting, or other hot work on coated metal surfaces; abrasive blasting of mail boxes and other equipment; and moving or cleaning of abrasive blasting enclosures.
Lockout/Tagout	Provide a copy of your lockout/tagout procedures, which must meet or exceed the OSHA Lockout/Tagout standard. You will be given access to and must review the Postal Service lockout/tagout program. If you encounter a Postal Service lockout/tagout device that prevents the continuation of work, do not make any attempts to remove, tamper with, or bypass the devices. Contact a Postal Service Maintenance official and make arrangements to have the lockout device removed in accordance with Postal Service lockout removal policies.
Machinery and Equipment	Postal facilities use state-of-the-art mail handling machinery, some of which may operate automatically. Hazards may include, but are not limited to, moving parts and power transmission apparatus, pinch points, electrical contact, and hot surfaces. Do not use machine surfaces as work platforms. Contact the designated Postal Service representative concerning facility machinery.
Personal Protective Equipment	Before beginning work, evaluate the work area for hazards, determine whether contract employees will be required to use personal protective equipment (PPE) to protect themselves from these hazards, and document the hazard assessment. Wear the PPE required by the postal facility in which you are working, regardless of your perception of hazard potential.
Regulated And Prohibited Materials	<i>Pesticides.</i> The Postal Service has restricted the use of pesticides. Obtain prior approval of the district environmental compliance coordinator for special cases that may require the use of pesticide treatments. <i>Chemical Prohibition.</i> Adhere to the Postal Service Hazard Communication Program and chemical prohibition policies. Do not use on postal property any of the chemicals prohibited by EPA unless a Postal Service person authorizes its use (each of these chemicals must be authorized separately). The USPS Office of Sustainability can supply the list. <i>Asbestos-Free Products.</i> Install no asbestos-containing products or materials in postal facilities. <i>Lead.</i> Apply no lead-based paint in postal facilities.
Scaffolding	Follow strictly the applicable OSHA scaffolding requirements. Provide adequate barrier protection around the scaffolding to prevent hazards to postal workers.
Walking and Working Surfaces	If the project requires temporary modifications to the means of egress, inform the designated Postal Service representative before performing such actions, provide appropriate alternative means of egress, and communicate these to all employees.

Emergency Procedures

Preparations for Emergency	<p>Be prepared for emergency situations. Ensure that emergency telephone numbers are site specific, readily available, easily read, and communicated to all employees. Train and authorize employees to implement emergency procedures.</p>
Medical Emergencies	<p>Have procedures and medical supplies to provide emergency medical services for your own personnel. Determine how to contact emergency medical services before work begins, and have on-site capabilities to contact such services immediately.</p>
Fires	<p>See Fire Protection above. In the event of a fire, you must:</p> <ul style="list-style-type: none"> - Immediately remove personnel from the area or building following Postal Service evacuation procedures. - Immediately contact the nearest postal employee and inform him or her of the fire. You may also activate an emergency alarm in the area. If no postal employees are on-site, immediately contact the local fire department. <p>Personnel trained in the use and limitations of fire extinguishers may attempt to extinguish the fire if it is safe to do so.</p>
Chemical Releases	<p>See Hazardous Materials above. If the event of a hazardous material release, you must:</p> <ul style="list-style-type: none"> - Immediately remove personnel from the area or building following Postal Service evacuation procedures. - Immediately contact the designated Postal Service representative and inform him or her of the release. You may also activate an emergency alarm in the area. If no postal employees are on-site, immediately contact the local fire department. <p>Contractor personnel should not respond to the release unless specifically trained and protected to perform hazardous material response.</p>
Power Outages	<p>In the event of a power outage, you must:</p> <ul style="list-style-type: none"> - Immediately stop work and assemble for a head count and possible facility egress. - Inform all contract employees that equipment may automatically restart when power resumes. - Immediately contact the designated Postal Service representative and inform him or her of the status of contract work and personnel head count. Relay at this time all hazards created due to the power outage. <p>When power resumes evaluate the status of operations that were being performed relative to hazard potential. For example, the interruption of ventilation in confined spaces may generate atmospheric hazards.</p>
Accident Investigation and Reporting	<p>As soon as is practical after an accident, investigate and document an accident investigation. The documentation must describe the incident and identify the causes and the corrective actions that will prevent future incidents. Report all accidents, whether or not they result in injury. Give the written report to the Postal Service COR within 24 hours of the accident or incident.</p>

Certificate of Asbestos and Lead-Based Paint (New Work)

To: Contracting Officer, United States Postal Service

Subject: Certification for new construction

Postal facility name: _____

Postal facility address: _____

Certification for new construction:

This Contractor/Owner hereby certifies that no asbestos-containing material in excess of 1 percent as defined by applicable US Environmental Protection Agency regulations, and no lead-based paint has been furnished or installed at the referenced project.

Contractor/Owner name: _____

Signature: _____

Address: _____

Telephone: _____

Date executed: _____

The penalty for making a false statement is prescribed by 18 USC 1001.

SECTION 014000

QUALITY REQUIREMENTS

PART 1 – GENERAL

1.1 CONTRACTOR QUALITY CONTROL

- A. Contractor Quality Control: The Contractor is responsible for the overall quality of all its own work and the work performed by their subcontractors working under this contract. The quality of any part of the work installed must not be less than that required by the technical divisions of this specification. If the COR determines that the quality of work does not conform to the applicable specifications and drawings, the Contractor will be advised in writing of the areas of nonconformance, and within 7 days the Contractor must correct the deficiencies and advise the COR in writing of the corrective action taken.
- B. Noncompliance with Quality Control Requirements: Failure of the Contractor to comply with the above requirements may be cause for termination for default as defined in the terms and conditions of the contract provisions and clauses, including those concerning, *Termination for Convenience or Default*, of the general contract clauses.

1.2 SUBMITTALS

- A. Prior to the start of on-site work, the Contractor must submit to the Contracting Officer a Contractor Quality Control Plan that includes the following information:
 - 1. Quality Control Organization: In chart form, showing relationship of Quality Control organization to other elements of Contractor's organization.
 - 2. Names and qualifications of personnel in Quality Control organization, including Contractor Quality Control Representative, inspectors, Independent Testing and Inspection Laboratory, and Independent HVAC Test and Balance Agency.
 - 3. Procedures for reviewing coordination drawings, shop drawings, certificates, certifications, or other submittals.
 - 4. Testing and inspection schedule, keyed to Construction Schedule, indicating tests and inspections to be performed, names of persons responsible for inspection and testing for each segment of work including preparatory, initial, and follow-up.
 - 5. Proposed forms to be used including Contractor's Daily Report, Contractor Test and Inspection Report and Non-Compliance Check-Off List.
- B. For independent testing and inspection laboratories, submit the following:
 - 1. Name.
 - 2. Address.
 - 3. Telephone number.
 - 4. Names of full time registered engineer.
 - 5. Responsible officer.
 - 6. Copy of report of laboratory facilities inspection made by Materials Reference Laboratory of National Bureau of Standards during most recent inspection, with memorandum of remedies of any deficiencies reported by inspection.

1.3 QUALITY CONTROL PROCEDURES

- A. Monitor quality control over Contractor staff, subcontractors, suppliers, manufacturers, products, services, site conditions, and workmanship.

- B. Comply fully with manufacturer's published instructions, including each step in sequence of installation.
- C. Should manufacturer's published instructions conflict with Contract Documents, request clarification from COR before proceeding.
- D. Comply with specified standards as a minimum quality for work, except where more stringent tolerances, codes, or specified requirements indicate higher standards or more precise workmanship.
- E. Perform work by persons who are thoroughly qualified and trained in their respective trade, to produce workmanship of specified quality.
- F. Perform tests required by governing authorities having jurisdiction and utilities having jurisdiction.

1.4 TESTING AND INSPECTION LABORATORY SERVICES

- A. Selection and Payment:
 - 1. The Contractor shall pay for services of an Independent Testing and Inspection Laboratory to perform specified testing and inspection.
 - 2. Employment of Independent Testing and Inspection Laboratory in no way relieves Contractor of obligation to perform work in accordance with requirements of Contract Documents.
- B. Quality Assurance:
 - 1. Comply with requirements of all applicable ASTM standards.
 - 2. Laboratory: Authorized to operate in State in which Project is located.
 - 3. Laboratory Staff: Maintain a full time registered engineer on staff to review services.
 - 4. Testing Equipment: Calibrated at reasonable intervals with devices of and accuracy traceable to either National Bureau of Standards or accepted values of natural physical constraints.
- C. Laboratory Responsibilities. Contractor shall ensure the Laboratory has the following responsibilities and limits on authority:
 - 1. Test samples of mixes submitted by Contractor.
 - 2. Provide qualified personnel at Project site. Cooperate with COR and Contractor in performance of services.
 - 3. Perform specified sampling, testing, and inspection of Products in accordance with specified standards.
 - 4. Determine compliance of materials and mixes with requirements of Contract Documents.
 - 5. Promptly notify Contractor Quality Control Representative and COR of observed irregularities or non-conformance of work or Products.
 - 6. Submit one copy of all test results directly to the COR.
 - 7. Perform additional tests as required by COR.
 - 8. Attend appropriate preconstruction meetings and progress meetings.
- D. Limits on Authority. Contractor shall ensure the Laboratory has the following limits on authority:
 - 1. Laboratory may not release, revoke, alter, or expand on requirements of Contract Documents.
 - 2. Laboratory may not approve or accept any portion of work.
 - 3. Laboratory may not assume any duties of Contractors.
 - 4. Laboratory has no authority to stop work.

1.5 CONTRACTOR FIELD INSPECTION AND TESTING

- A. Contractor: Test and Inspect work provided under this Contract to ensure work is in compliance with Contract requirements. Required tests and inspections are indicated in each individual Specification Section.

- B. Preparatory Inspection: Performed prior to beginning work and prior to beginning each segment of work and includes:
 - 1. Review of Contract requirements.
 - 2. Review of shop drawings and other submittal data after return and approval.
 - 3. Examination to assure materials and equipment conform to Contract requirements.
 - 4. Examination to assure required preliminary or preparatory work is complete.
- C. Initial Inspection: Performed when representative portion of each segment of work is completed and includes:
 - 1. Performance of required tests.
 - 2. Quality of workmanship.
 - 3. Review for omissions or dimensional errors.
 - 4. Examination of products used, connections and supports.
 - 5. Approval or rejection of inspected segment of work.
- D. Follow-Up Inspections: Performed daily, and more frequently as necessary, to assure non-complying work has been corrected.
- E. Testing and Inspection: Perform testing and inspection in accordance with requirements in individual Specification Sections.

1.6 CONTRACTOR'S DAILY REPORT

- A. In accordance with the terms and conditions of the contract provisions and clauses, including those concerning *Performance and Superintendence of Work by Contractor*, the Contractor shall submit daily report to COR, for days that work was performed. Include the following information:
 - 1. Date, weather, minimum and maximum temperatures, rainfall, and other pertinent weather occurrences.
 - 2. Daily workforce of Contractor and subcontractors, by trades.
 - 3. Description of work started, ongoing work, and work completed by each subcontractor.
 - 4. Coordination implemented between various trades.
 - 5. Approval of substrates received from various trades.
 - 6. Nonconforming and unsatisfactory items to be corrected.
 - 7. Remarks, to include at a minimum, any potential delays, schedule changes, workplace incidents or other items of note. However, nothing reported herein shall relieve the Contractor of the separate responsibility under other terms and conditions of the Contract provisions and clauses to provide specific notice to the Contracting Officer,

1.7 CONTRACTOR'S TEST AND INSPECTION REPORTS

- A. Prepare and submit, to COR, a written report of each test or inspection signed by Contractor Quality Control Representative performing inspection within 2 days following day inspection was made.
- B. Include the following on written reports of inspection:
 - 1. Cover sheet prominently identifying that inspection "CONFORMS" or "DOES NOT CONFORM" to Contract Documents.
 - 2. Date of inspection and date of report.
 - 3. Project name, location, solicitation number, and Contractor.
 - 4. Names and titles of individuals making inspection, if not Contractor's Project Field Superintendent.
 - 5. Description of Contract requirements for inspection by referencing Specification Section.
 - 6. Description of inspection made, interpretation of inspection results, and notification of significant conditions at time of inspection.
 - 7. Requirements for follow-up inspections.

1.8 NON-COMPLIANCE CHECK-OFF LIST

- A. Maintain check-off list of work that does not comply with Contract Documents, stating specifically what is non-complying, date faulty work was originally discovered, and date work was corrected. No requirement to report deficiencies corrected same day it was discovered. Submit copy of Non-Compliance Check-Off List of non-complying work items to COR on a weekly basis.

1.9 COMPLETION AND INSPECTION OF WORK

- A. Prior to final acceptance by Contracting Officer, submit a certification signed by Contractor to Contracting Officer stating that all work has been inspected and all work, except as specifically noted, is complete and in compliance with Contract Documents.

PART 2 – PRODUCTS

NOT USED

PART 3 – EXECUTION

NOT USED

END OF SECTION

USPS Specification Last Revised: 10/1/2022

SECTION 015000

TEMPORARY FACILITIES AND CONTROLS

PART 1 – GENERAL

1.1 SUMMARY

- A. Provide all temporary facilities and services required to complete the Work and to comply with OSHA and other applicable regulations.
- B. Maintain temporary facilities in a proper, safe, operating and sanitary condition for the duration of this Contract. Upon completion of this Contract, all such temporary work and facilities shall be removed in their entirety and the premises will be restored to its prior condition.

1.2 RELATED SECTIONS

- A. Section 015600 - Temporary Barriers and Enclosures

1.3 PROJECT SIGNAGE

- A. Provide and maintain a construction project sign at the location directed by the COR. The sign to conform to the Construction Sign as detailed in the Contract drawings. The information to complete the wording on the sign is provided by the COR. Erect the sign within 15 days after receiving a Notice to Proceed. The sign to be removed upon completion of the Work and destroyed, and the premises restored to its prior condition.
- B. Construction Site Sign:
 - 1. Silk-screened, painted or pressure-sensitive vinyl letters applied to Medium Density Overlay plywood sign.
 - 2. Red: Match Benjamin Moore OP-67.
 - 3. Blue: Match PPG 7062 Federal Blue.
 - 4. White background.
- C. Construct and erect a minimum of two hard hat signs at locations designated by the COR. Signs to be erected prior to the commencement of on-site work.
- D. Other signage: No unapproved signs, brand logos, or graphics shall be affixed to temporary walls, partitions, doors, barricades and fences.

1.4 PROJECT BULLETIN BOARD

- A. Provide a weatherproof bulletin board, not less than 36 inches wide and 30 inches high, with hinged glass door adjacent to, or mounted on, the Contractor's project office. If adjacent to the office, the bulletin board to be securely mounted on not less than two posts. The bulletin board and posts to be painted or have approved factory finish. The bulletin board to be easily accessible at all times and contain wage rates, equal opportunity notice, and other items required to be posted.
- B. Maintain the bulletin board in good condition throughout the life of the project. The bulletin board will remain the property of the Contractor and upon completion of the project be removed from the site and the premises restored to its prior condition.

1.5 CONSTRUCTION-USE UTILITIES

- A. Arrange with the local utility companies for gas, water, and electricity required for construction under this project and pay all costs in connection with them. The Contractor to, at its own expense, make all temporary connections and install distribution lines. All temporary lines to be maintained by the Contractor in a manner satisfactory to the COR and to be removed by in like manner before final acceptance of the construction.

1.6 TEMPORARY ELECTRIC

- A. **Costs:** Make arrangements with the serving utility for power, pay deposits, and install equipment, poles, wiring, switches, and outlets necessary to provide adequate supply for lighting and power for construction purposes. Pay for power used during construction and for removal of all temporary equipment.
- B. **Service Required:** Provide temporary electric power throughout the construction period so that power can be secured at any desired point with no more than a 100-foot extension cord; power centers for miscellaneous tools and equipment used in the construction work (not less than one per 2,000 square feet of floor space, consisting of a weatherproof distribution box with a minimum of four 20-amp, 120-volt grounded outlets with a circuit breaker protection for each outlet); lighting for safe and adequate working conditions throughout buildings and stairways (at least 1/4 watts of incandescent lighting per square foot, with a socket voltage of at least 110 volts and using 100 watt lamps minimum); power for construction site offices and other temporary storage and construction building; and power for testing and checking equipment welding units, and terrazzo grinders.
- C. **Safety:** Provide and maintain lights and signs to prevent damage or injury and illuminate all hazardous areas. Safety lights to be kept burning from dusk to dawn.
- D. **Requirements of Regulatory Agencies:** Obtain permits as required by local government authorities; obtain easements as required across private property other than that of the owner for temporary power service; and comply with the National Electrical Code, applicable local codes, and utility regulations.
- E. **Use of Permanent System:** Regulate all parts of the permanent electrical system that is used for construction purposes in order to prevent interference with safety and with the orderly progress of the Work. Leave permanent electrical services in a condition as good as new.
- F. **Materials:** Materials may be new or used but will be adequate in capacity for the purposes intended and will not create unsafe conditions or violate the requirements of applicable codes. At the Contractor's option, patented specialty materials may be used if UL-approved.
- G. **Conductors:** Use wire, cable, or busses of appropriate type, sized in accordance with the National Electrical Code for the applied loads. Use only UL-approved wire.
- H. **Equipment:** In compliance with NEMA standards, provide an appropriate enclosure for the environment in which the equipment is used.
- I. **Installation:** Provide all required facilities, including transformers, conductors, poles, conduits, raceways, fuses, switches, fixtures, and lamps, located so as to avoid interference with cranes and materials-handling equipment, storage areas, traffic areas, and work under other contracts. All work to have a neat and orderly appearance and be structurally sound throughout, and properly maintained to give continuous service and to provide safe working conditions. Modify the service as required by the progress of the Work.
- J. **Removal:** Remove all temporary equipment and materials upon completion of construction, repair all damage caused by the installation, and restore the premises to its prior condition.

1.7 TEMPORARY HEATING AND VENTILATION

- A. Provide cold weather protection and temporary heat and fuel as required to carry on the Work expeditiously during inclement weather, protect all work and materials against damage from dampness and cold, dry out the building, and provide suitable working conditions for the installation and curing of materials until final acceptance by the Contracting Officer. Refer to requirements in detailed specifications for temperatures to be provided and maintained for installation and curing of work under the various trades.
- B. Provide temporary heat consisting of smokeless heating appliances satisfactory to the COR. Furnish and pay for all necessary fuel and attendants in any trade and maintain temporary heat at temperatures adequate for the intended purpose.
- C. When the permanent heating system is operable and the Contractor elects to use it, the Contractor to provide all fuel, labor, materials, services, equipment, and attendants necessary to operate the permanent heating system for temporary heat and to maintain a minimum temperature as specified in the terms and conditions of the contract provisions and clauses, including those concerning *Heat*. If the permanent system is used to provide temporary heating and ventilation, the Contractor to replace all filters and restore the system to a condition satisfactory to the COR.

1.8 TEMPORARY FIRE PROTECTION

- A. Install and maintain temporary fire-protection facilities and equipment of sufficient size and types needed to protect against reasonably predictable and controllable fire losses. Comply with NFPA 241.
- B. Prohibit smoking outside of areas designated by USPS.
- C. Supervise welding operations, combustion-type temporary heating units, and similar sources of fire ignition according to requirements of authorities having jurisdiction.
- D. Develop and supervise an overall fire-prevention and -protection program for personnel at Project site. Review requirements with USPS personnel and local fire department and establish procedures to be followed. Instruct personnel in methods and procedures. Post warnings and information.
- E. Take all precautions to prevent possibility of fire resulting from construction operations. Particularly avoid hazardous accumulations of rubbish and unsecured, flammable materials.
- F. Provide emergency fire extinguishing equipment of adequate type and quantity, readily available and properly maintained.

1.9 TEMPORARY FIRST AID FACILITIES

- A. Provide adequate first aid facilities and equipment for construction personnel.

1.10 TEMPORARY WATER

- A. Provide and maintain a temporary water supply system for building purposes, extending branches to convenient points and terminating them with a proper stop and hose connection. Before any paving is laid, the temporary supply to be removed and the tap in the main supply properly capped.

1.11 SANITARY PROVISIONS

- A. Provide and keep in neat and sanitary condition conveniences and accommodations for the use of the construction personnel necessary to comply with the requirements and regulations of the local department of health and of other bodies having jurisdiction.

1.12 APPROACHES AND EXITS

- A. Provide all necessary approaches and exits required to properly execute the Work.
- B. In connection with these, provide for temporary drainage to keep the site free from standing water at all times.

1.13 TEMPORARY BARRIERS AND ENCLOSURES

- A. All construction activities are required to be secured and separated from areas accessible to the public and USPS operations. Construct all temporary barricades, enclosures, fences and components for their specific and intended use, and to meet local code requirements, including wind load design.
- B. Coordinate the placement of barriers and enclosures that impact fire pull boxes, lighting, CCTV cameras, fire suppression systems, and exit doors with the COR and designated facility personnel at least two weeks in advance of barricade installation.
- C. Cover interior and exterior windows facing the construction with 3/4-inch exterior grade plywood. Paper and plastic coverings are not acceptable.
- D. Caution tape, plastic chain, and traffic cones are not approved barriers, and may only be used in an emergency situation, and must be replaced within 24-hours with an approved barricade.
- E. Provide dustproof temporary partitions from the floor to the underside of the deck sufficient to separate construction areas from the rest of the building to reduce construction noise and prevent the migration of dust, dirt, and fumes beyond the construction area.
- F. Partition Construction: Enclose the construction area with 6-mil anti-static fire-retardant reinforced polyethylene sheeting supported by framework and be capable of resisting 0.5 pounds-per-square-foot of force applied over the entire surface of each side, separately. Overlap the sheeting at least 6 inches and seal continuously with anti-static fire-retardant reinforced tape.
- G. Partition Construction: Metal studs at 16 inches on center braced as necessary, with 3/4-inch plywood [over 6-mil anti-static fire-retardant reinforced polyethylene sheeting] screwed to the studs on the non-construction side of the partition. Overlap the sheeting at least 6 inches and seal continuously with anti-static fire-retardant reinforced tape.
- H. Protect existing floor and finish flooring material beneath panels and within the construction area shall with 1/4-inch hardboard over 6-mil anti-static fire-retardant reinforced polyethylene sheeting. Overlap the sheeting at least 6 inches and seal with anti-static fire-retardant reinforced tape.

1.14 POSTAL SERVICE FIELD OFFICE

- A. Within 30 days after receiving a Notice to Proceed, furnish a building or trailer having a minimum of [] square feet of floor space to serve as a USPS temporary field office reserved for Postal Service use only. Locate where directed. Furnish and maintain drinking water facilities, adequate lighting, ventilation, heating, air-conditioning equipment, a copy machine, and a partition-enclosed chemical toilet. Provide hook-up to utility services and telephone services and pay the cost of all services except long-distance phone calls. Used field office buildings and used furniture and equipment in good condition are

acceptable. Equip entrance doors with a substantial lock. Provide janitorial services. If a building is provided, it will be constructed to be easily moved, and relocate the building twice during the contract, if directed to do so. All-weather vehicle and pedestrian access and all-weather parking areas for six cars to be provided at the field office location. The temporary field office, including furniture, except for any office equipment including computers, printers, FAX machines, etc., to remain the property of the Contractor and be removed from the site after the Work is completed. The premises will be restored to its prior condition.

- B. Detailed List of Furnishings and Equipment: See Attachment at the end of this section for a list of equipment to be included in the USPS field office.

1.15 PROJECT PHOTOS

- A. Provide photographs of the Work with the intended purpose of illustrating, generally, the work in place at specific points in time.
1. Frequency: Weekly and with every payment application
 2. Media: Digital JPG format
 3. Number: Minimum of 30 separate viewpoints
 4. Content: Views from each of the cardinal points of the compass

PART 2 – PRODUCTS

NOT USED

PART 3 – EXECUTION

NOT USED

END OF SECTION

USPS Specification Last Revised: 10/1/2022

SECTION 015600
TEMPORARY BARRIERS AND ENCLOSURES

PART 1 - GENERAL

1.1 SUMMARY

- A. Provide barriers and enclosures to protect the Work, existing facilities, and USPS operations from unauthorized entry, vandalism, and theft, and as required to complete the Work and to comply with OSHA and other applicable regulations.
- B. Maintain temporary barriers and enclosures in a proper, safe condition for the duration of the Contract. Before completion of the Work, remove temporary work in their entirety and restore the premises to its prior condition.

1.2 RELATED SECTIONS

- A. Section 013300 - Submittal Procedures
- B. Section 015000 - Temporary Facilities and Controls.

1.3 SUBMITTALS

- A. Temporary Barrier and Enclosure Plan: Plan to include the types and positions of temporary barriers and enclosures for every phase of the work, illustrate egress pathways, and indicate the location doors and gates, fire watch windows, and required signage.
- B. Temporary Barrier and Enclosure Details: Indicate materials, construction, and anchoring systems.
- C. Modify and resubmit all plans and details should the actual placement and construction of the barriers and enclosures substantially change during construction of the Work.
- D. Product Data:
 - 1. Anti-static fire-retardant reinforced polyethylene sheeting
 - 2. Woven opaque polypropylene panels
 - 3. Temporary interior horizontal protection system.

1.4 GENERAL REQUIREMENTS

- A. All construction activities are required to be secured and separated from areas accessible to the public and USPS operations.
- B. Design and construct all temporary barricades, enclosures, fences and components for their specific and intended use, and to meet local code requirements, including wind load design.
- C. Construct temporary barriers and enclosures with the least possible obstruction and inconvenience to USPS operations and occupants, and the public.
- D. Construct and maintain temporary barriers and enclosures to be straight, clean and uniform in appearance. Inspect barriers and enclosures daily and replace or repair substantially damaged materials immediately.
- E. Coordinate the placement of barriers and enclosures that impact fire pull boxes, lighting, CCTV cameras, fire suppression systems, and exit doors with the COR and designated facility personnel at least two weeks in advance of barricade installation.
- F. Barricades and fences that are used for traffic guardrails, or to protect against falls, shall be designed to resist an overturning moment created by the force of 50 pounds per lineal foot applied

horizontally at the height of 3 feet 6 inches perpendicular to the partition for the full length of the partition, or as required by code.

- G. Cover interior and exterior windows facing the construction with 3/4-inch exterior grade plywood. Paper and plastic coverings are not acceptable.
- H. Caution tape, plastic chain, and traffic cones are not approved barriers, and may only be used in an emergency situation, and must be replaced within 24-hours with an approved barricade.

1.5 TEMPORARY SITE BARRICADES AND FENCES

- A. Use exterior concrete barricades and chain link fencing to enclose the construction site. Use only easily movable barricades in locations needed for equipment, personnel, and emergency vehicle access.
- B. Barricades used to close off previously active vehicle roadways will have red flashing lights mounted 4 feet above the road surface, 5 feet on center across the width of the roadway.
- C. Provide chain link gates construction vehicles entrances and exits. Chain and padlock gates tightly at all times when not in use.
- D. Construction Fencing: 8-foot chain link with posts buried in the ground. Fence mesh fabric constructed of minimum 9-gauge steel wire with a maximum mesh opening of 2 inches.
- E. Cover chain link fencing on the public side with black woven opaque polypropylene panels with hemmed edges and grommets. Securely and tautly attach the polypropylene panels to the posts and rails using wire through the panel grommets. Replace substantially damaged panels immediately. Panels with wind slits are permitted when necessary.

1.6 TEMPORARY EXTERIOR ENCLOSURES

- A. Provide temporary insulated weather-tight closure of exterior openings to create acceptable working conditions, protect the existing building and the Work, to contain heating and cooling, and to prevent entry of unauthorized persons.
- B. Exterior Temporary Doors: Provide doors with self-closing and self-locking hardware as appropriate to meet exiting requirements required by local code. The passive leaf for double doors to have top and bottom cane bolts. Doors to remain locked at all times. When doors are open for delivery of materials, the entrance must be staffed to prevent unauthorized entry. Provide code-compliant exit signage at each door as necessary.
 - 1. Door construction: Pre-hung hollow-metal with 1-1/2 pair hinges per leaf; fire-rated as necessary.

1.7 TEMPORARY INTERIOR PARTITIONS

- A. Provide dustproof temporary partitions from the floor to the underside of the deck sufficient to separate construction areas from the rest of the building to reduce construction noise and prevent the migration of dust, dirt, and fumes beyond the construction area.
- B. Protect existing floor and finish flooring material beneath panels and within the construction area shall with 1/4-inch hardboard over 6-mil anti-static fire-retardant reinforced polyethylene sheeting. Overlap the sheeting at least 6 inches and seal with anti-static fire-retardant reinforced tape.
- C. Provide temporary electrical power outlets on nearby walls outside the construction area as requested by the COR to replace those outlets that are covered by temporary partitions.
- D. Adjoin temporary partitions to existing walls with no gaps in a neat and tidy manner that protects existing surfaces from damage.
- E. Partition Construction: Enclose the construction area with 6-mil anti-static fire-retardant reinforced polyethylene sheeting supported by framework and be capable of resisting 0.5 pounds-per-square-

foot of force applied over the entire surface of each side, separately. Overlap the sheeting at least 6 inches and seal continuously with anti-static fire-retardant reinforced tape.

- F. Partition Construction: Metal studs at 16 inches on center braced as necessary, with 3/4-inch plywood over 6-mil anti-static fire-retardant reinforced polyethylene sheeting screwed to the studs on the non-construction side of the partition. Overlap the sheeting at least 6 inches and seal continuously with anti-static fire-retardant reinforced tape.
- G. Interior Temporary Doors: Provide doors with self-closing and self-locking hardware as appropriate to meet exiting requirements required by local code. The passive leaf for double doors to have top and bottom cane bolts. Doors to remain locked at all times. When doors are open for delivery of materials, the entrance must be staffed to prevent unauthorized entry. Provide code-compliant exit signage at each door as necessary.
 - 1. Door construction: Pre-hung hollow-metal with 1-1/2 pair hinges per leaf; fire-rated as necessary.

1.8 TEMPORARY INTERIOR HORIZONTAL PROTECTION

- A. Construction: Anti-static fire-retardant reinforced framework, attachment method, sheeting, and netting sufficient to resist the impact of the largest and heaviest falling debris possible, and to contain and prevent dust, dirt, and small particles from migrating to spaces below or adjacent to the construction work area.
- B. Install directly beneath the existing roof and floor deck at a height that accommodates operations below to continue and construction work to occur above.
- C. Fasten system to the existing structure in a secure manner seal seams sealed in a manner that does not allow for debris infiltration. The completed system shall be installed to provide maximum dust and debris protection during all phases of roof replacement activities.
- D. Provide sealed openings to accommodate the penetration of structure, ductwork, lighting, conduits, etc. without impeding the function of such systems.
- E. Seal and protect existing building systems that may extend horizontally between deck and the horizontal protection.
- F. If the horizontal protection blocks or prohibits the proper function of lighting fixtures, cooling, and/or heating, then provide temporary services to the affected area.
- G. At locations where continuous access may be needed, provide resealable openings. Such access points include, but are not limited to, access ladders, equipment hatches, ductwork, piping, and conduit. Prior to installation, review locations with designated facility personnel and the COR.
- H. Install horizontal protection in a manner that does not affect the proper operation of fire alarm and fire suppression systems. In areas where this is not possible, prepare, in coordination with designated facility personnel and the COR, a Fire Watch plan. It may also be necessary to remove portions, or the entire, horizontal protection system at the completion of each day's work.
- I. Daily Inspections:
 - 1. Prior to the start of work: Inspect the area above and below horizontal protection system. Prepare a written report noting the location of materials and equipment that may be impacted by the work and submit the report to designated facility personnel and the COR. Make all necessary adjustments and repairs to the protection system as directed.
 - 2. During work in progress: Maintain interior spotters beneath the work area and horizontal protection system with capability to communicate immediately with the crew members above.
 - 3. At the completion of that day's work: Inspect the area above and below horizontal protection system. Prepare a written report noting the overall integrity of the protection system and any damage to building systems. Repair essential building systems immediately. Provide necessary repairs as needed to restore the integrity of the protection system.

- J. After completion of project work, remove the protection system in coordination with designated facility personnel and the COR. Remove the system carefully and in a manner that reduces the risk of debris, dust or moisture being released from containment. Clean the floor, all equipment and the surfaces of building systems, components, and structure.

PART 2 - PRODUCTS

Not Used

PART 3 - EXECUTION

Not Used

END OF SECTION

USPS Specification Last Revised: 10/1/2022

SECTION 016000

PRODUCT REQUIREMENTS

PART 1 – GENERAL

1.1 PRODUCT OPTIONS AND SUBSTITUTIONS

- A. Refer to contract provisions and clauses:
 - 1. Provision 2-7, Brand Name or Equal.
 - 2. Clause F-401, Optional Materials or Methods.
- B. Provide Products that comply with Contract Documents, which are undamaged and new at time of installation.
- C. Provide Products complete with accessories, fasteners, trim, finish, safety guards, and other devices and details needed for complete installation and intended use and effect.
- D. Substitutions may be considered if:
 - 1. An equal product was proposed during the solicitation and was accepted, in writing, by the Postal Service prior to award of the Contract.
 - 2. During the course of the Work a Product becomes unavailable and the Contractor:
 - a. Represents that the proposed substitute Product has been investigated and it has been determined that it is equal or superior in all respects to that specified;
 - b. Will provide the same guarantee for the substitution that he would for that specified; and
 - c. Will coordinate the installation of the accepted substitute, making such changes as may be required for the Work to be complete in all respects, at no additional cost to the Postal Service and at no extension to Contract Time.

1.2 PRODUCT DELIVERY REQUIREMENTS

- A. Transport and handle Products in accordance with manufacturer's instructions, using means and methods that will prevent damage, deterioration, and loss, including theft.
- B. Schedule Product delivery to minimize long-term storage at Project site and prevent overcrowding of construction spaces.
- C. Coordinate Product delivery with installation schedule to assure minimum holding time for items that are flammable, hazardous, easily damaged, or sensitive to deterioration, theft, and other losses.
- D. Deliver Products to Project site in undamaged condition in manufacturer's original sealed container or other packaging system, complete with labels and instructions for handling, storing, unpacking, protecting, and installing.
- E. Promptly inspect shipments to ensure that Products comply with project requirements, quantities are correct, Products are undamaged, and properly protected.
- F. Provide equipment and personnel to handle Products by methods to prevent soiling, disfigurement, or damage.

1.3 PRODUCT STORAGE AND HANDLING REQUIREMENTS

- A. Store and protect Products in accordance with manufacturers' published instructions, with seals and labels intact and legible.

- B. Store Products subject to damage by elements above ground, under cover in weathertight enclosure, with ventilation adequate to prevent condensation. Maintain temperature and humidity within range required by manufacturer's published instructions.
- C. For exterior storage of fabricated Products, place on sloped supports, above ground.
- D. Provide off-site storage and protection when Project site does not permit on-site storage or protection.
- E. Cover Products subject to deterioration with impervious sheet covering. Provide ventilation to avoid condensation or potential degradation of Products.
- F. Store loose granular materials on solid flat surfaces in a well-drained area. Prevent mixing with foreign matter.
- G. Provide equipment and personnel to store Products by methods to prevent soiling, disfigurement, or damage.
- H. Arrange storage of Products to permit access for inspection. Periodically inspect to verify Products are undamaged and are maintained in acceptable condition.

PART 2 – PRODUCTS

NOT USED

PART 3 – EXECUTION

NOT USED

END OF SECTION

USPS Specification Last Revised: 10/1/2022

SECTION 017300

EXECUTION

PART 1 – GENERAL

1.1 LAYOUT OF WORK

- A. The Contractor must lay out its work from Postal Service-established base lines and benchmarks indicated on the drawings and is responsible for all measurements based on them. The Contractor must furnish, at its own expense, all stakes, templates, platforms, equipment, tools, materials, and labor as may be required in laying out any part of the work from the base lines and benchmarks established by the Postal Service. The Contractor is responsible for the execution of the work to those lines and grades established or indicated by the COR.

1.2 CONTRACTOR'S TEMPORARY USE OF FACILITIES AND EQUIPMENT

- A. No new facilities or equipment intended for the permanent installation, including materials-handling vehicles, may be used for temporary purposes unless specified in the Contract or unless the Contractor has the written permission of the COR.

1.3 FOR CONTRACT WORK PERFORMED IN AN EXISTING OCCUPIED POSTAL FACILITY

- A. The Postal Service will continue to operate the facility during performance of the work. Accordingly, the Contractor must arrange and schedule contract work to facilitate such continued use of the site and building, with minimal disruption to Postal operations. Contract work that cannot be performed during normal Postal operating hours and must be performed after hours or during periods when the facility is normally closed, must be coordinated with the COR.
- B. If contract work is being performed on the roof, or above or near electronic equipment or mail processing equipment, Contractor must provide temporary interior protection above and/or around such equipment as appropriate or as indicated in construction documents. Interior protection shall be anti-static 6-mil poly. Remove temporary protection upon completion of the work. Coordinate interior protection with local management.

1.4 CLEANING

- A. Refer to the terms and conditions of the contract provisions and clauses, including those clauses *Debris and Clean Up*.
- B. Cleaning During Construction:
 - 1. Maintain areas free of waste materials, debris, and rubbish. Maintain site in a clean and orderly condition.
 - 2. Remove debris and rubbish from pipe chases, plenums, attics, crawl spaces, and other closed or remote spaces, prior to enclosing the space.
 - 3. Broom and vacuum clean interior areas prior to start of surface finishing, and continue cleaning to eliminate dust.
 - 4. Collect and remove waste materials, debris, and rubbish from site as specified in the Environmental Compliance and Management Plan as required in Section 013543 - Environmental Procedures.
- C. Final Cleaning:

1. Use cleaning materials and agents recommended by manufacturer or fabricator of surface to be cleaned. Do not use cleaning agents that are potentially hazardous to health or property, or that might damage finished surfaces.
2. Employ experienced workers or professional cleaners for final cleaning. Clean each surface or unit of Work to condition expected from a commercial building cleaning and maintenance program. Comply with manufacturer's published instructions.
3. Complete following cleaning operations before requesting COR inspection for Substantial Completion.
 - a. Clean Project Site, yard and grounds, in areas disturbed by construction activities, including landscape development areas, of rubbish, waste materials, litter and foreign substances. Sweep paved areas broom clean. Remove petro-chemical spills, stains and other foreign deposits. Rake grounds that are neither planted nor paved, to a smooth even-textured surface.
 - b. Remove tools, construction equipment, machinery and surplus material from Project Site.
 - c. Remove snow and ice to provide safe access to building.
 - d. Clean exposed exterior and interior hard-surfaced finishes to a dirt-free condition, free of stains, films and similar foreign substances. Avoid disturbing natural weathering of exterior surfaces. Restore reflective surfaces to their original condition.
 - e. Remove debris and surface dust from limited access spaces, including roofs, plenums, shafts, trenches, equipment vaults, manholes, attics and similar spaces.
 - f. Broom clean concrete floors in unoccupied spaces.
 - g. Provide final cleaning, waxing, and buffing of resilient tile, in accordance with manufacturer's requirements.
 - h. Vacuum clean carpet and similar soft surfaces, removing debris and excess nap. Shampoo if required.
 - i. Clean transparent materials, including mirrors and glass in doors and windows. Remove glazing compounds and other substances that are noticeable vision-obscuring materials. Replace chipped or broken glass and other damaged transparent materials. Polish mirrors and glass, taking care not to scratch surfaces.
 - j. Remove labels that are not permanent labels.
 - k. Touch-up and otherwise repair and restore marred exposed finishes and surfaces. Replace finishes and surfaces that can not be satisfactorily repaired or restored, or that show evidence of repair or restoration. Do not paint over "UL" and similar labels, including mechanical and electrical name plates.
 - l. Wipe surfaces of mechanical and electrical equipment, and other similar equipment. Remove excess lubrication, paint and mortar droppings and other foreign substances.
 - m. Clean plumbing fixtures to a sanitary condition, free of stains, including stains resulting from water exposure.
 - n. Replace air disposable filters and clean permanent air filters. Clean exposed surfaces of diffusers, registers, and grills. Clean ducts, blowers, and coils if units were operated without filters during construction.
 - o. Clean light fixtures, lamps, globes and reflectors to function with full efficiency. Replace burned out bulbs, and defective and noisy starters in fluorescent and mercury vapor fixtures.
 - p. Leave Project clean and ready for occupancy.
4. Engage an experienced licensed exterminator to make a final inspection, and rid Project of rodents, insects, and other pests. Comply with regulations of local authorities having jurisdiction.
5. Remove temporary protection and facilities installed during construction to protect previously completed installations during remainder of construction.
6. Comply with governing regulations and safety standards for cleaning operations. Remove waste materials from Project Site and dispose of in accordance with requirements of local authorities having jurisdiction.
7. Where extra materials of value remain after completion of construction, they become Postal Service property and these materials should be stored as directed by COR.

PART 2 – PRODUCTS

017300 - 2

NOT USED

PART 3 – EXECUTION

NOT USED

END OF SECTION

USPS Specification Last Revised: 10/1/2022

SECTION 017419

CONSTRUCTION WASTE MANAGEMENT AND DISPOSAL

PART 1 - GENERAL

1.1 SUMMARY

- A. Section includes: Procedures for achieving the most environmentally conscious Work feasible within the limits of the Construction Schedule, Contract Sum, and available materials, equipment, and products.
1. Participate in promoting efforts of Postal Service to create an energy-efficient and environmentally-sensitive structure.
 2. Use recycled-content, toxic-free, and environmentally-sensitive materials and equipment.
 3. Use environmentally-sensitive procedures.
 - a. Protect the environment, both on-site and off-site, during demolition and construction operations.
 - b. Prevent environmental pollution and damage.
 - c. Effect optimum control of solid wastes.
- B. Related Documents: The Contract Documents, as defined in Section 011000 - Summary of Work, apply to the Work of this Section. Additional requirements and information necessary to complete the Work of this Section may be found in other documents.
- C. Related Sections:
1. Section 013200 - Construction Progress Documentation.
 2. Section 014000 - Quality Requirements: Contractor's Daily Report.
 3. Section 015000 - Temporary Facilities And Controls: Temporary ventilation, progress cleaning and waste removal.
 4. Section 016000 - Product Requirements: Substitutions.
 5. Section 017704 - Closeout Procedures and Training: Record submittals.
 6. Section 024113 - Selective Site Demolition.

1.2 DEFINITIONS

- A. Adequate ventilation: Ventilation, including air circulation and air changes, required to cure materials, dissipate humidity, and prevent accumulation of dust fumes, vapors, or gases.
- B. Construction and demolition waste: Includes solid wastes, such as building materials, packaging, rubbish, debris, and rubble resulting from construction, remodeling, repair, and demolition operations.
1. Rubbish: Includes both combustible and noncombustible wastes but excludes recyclable materials such as paper, boxes, glass, metal, lumber scrap and metal cans.
 2. Debris: Includes both combustible and noncombustible wastes, such as leaves and tree trimmings, stumps and rubble that result from construction or maintenance and repair work.
- C. Chemical waste: Includes petroleum products, bituminous materials, salts, acids, alkalis, herbicides, pesticides, organic chemicals, and inorganic wastes.
- D. Diversion: Redirection of waste ordinarily deposited in a municipal landfill to a recycling facility or to another destination for reuse.
- E. Environmental pollution and damage: The presence of chemical, physical, or biological elements or agents, which adversely affect human health or welfare; unfavorably alter ecological balances; or degrade the utility of the environment for aesthetic, cultural, or historical purposes.

- F. Hazardous materials: Includes pesticides, biocides, and carcinogens as listed by recognized authorities, such as the Environmental Protection Agency (EPA) and the International Agency for Research on Cancer (IARC).
- G. Interior final finishes: Materials and products that will be exposed at interior, occupied spaces; including flooring, wallcovering, finish carpentry, and ceilings.
- H. Municipal Solid Waste Landfill: A permitted facility that accepts solid, non-hazardous waste such as household, commercial, and industrial waste, including construction and demolition waste.
- I. Packaged dry products: Materials and products that are installed in dry form and are delivered to the site in manufacturer's packaging; including carpets, resilient flooring, ceiling tiles, and insulation.
- J. Sediment: Soil and other debris that has been eroded and transported by storm or well production runoff water.
- K. Sanitary wastes:
 - 1. Garbage: Refuse and scraps resulting from preparation, cooking, distribution, or consumption of food.
 - 2. Sewage: Domestic sanitary sewage.
- L. Wet products: Materials and products installed in wet form, including paints, sealants, adhesives, and special coatings.

1.3 SUBMITTALS

- A. Solid Waste Management and Environmental Protection Plan: Prepare and submit at the Preconstruction Meeting a Solid Waste Management and Environmental Protection Plan including, but not limited to, the following:
 - 1. Procedures for Recycling/Re-Use Program.
 - 2. Schedule for application of interior finishes.
 - 3. Revise and resubmit Solid Waste Management and Environmental Protection Plan as required by Postal Service.
 - a. Approval of the Contractor's Solid Waste Management and Environmental Protection Plan, will not relieve the Contractor of responsibility for adequate and continuing control of pollutants and other environmental protection measures.
 - 4. Any permits required by local, state or federal agencies.
- B. With each Contractor's Report as specified in Section 014000 – Quality Requirements, submit an updated Summary Of Solid Waste Disposal And Diversion. Submit on form in Appendix A of this Section. Include manifests, weight tickets, receipts, and invoices specifically identifying the Project and waste material for:
 - 1. Municipal Solid Waste Landfills.
 - 2. Recycling/Reuse Facilities.
- C. With Record Submittals as specified in Section 017704 - Closeout Procedures and Training, submit the following:
 - 1. Final Summary Of Solid Waste Disposal And Diversion. Submit on form in Appendix A of this Section.
 - 2. Resource Conservation and Recovery Act Project Summary. Submit on form in Appendix B of this Section.

PART 2 – PRODUCTS

017419-2

NOT USED

PART 3 – EXECUTION

3.1 RECYCLING AND REUSE

- A. Collection: Implement a recycling/reuse program that includes separate collection of waste materials of the following types as appropriate to authorized local and regional recycling/reuse facilities:
1. Asphalt.
 2. Concrete.
 3. Metal.
 - a. Ferrous.
 - b. Non-ferrous.
 4. Wood.
 5. Debris.
 6. Glass.
 7. Clay brick.
 8. Paper/Cardboard.
 9. Plastic.
 10. Gypsum.
 11. Paint.
 12. Carpet.
 13. Others as appropriate.
- B. Recycling/reuse centers: Contact state and/or local governmental solid waste offices, Environmental Protection Agency (EPA) regional offices, and authorized applicable non-profit organizations.
1. Asphalt
 2. Concrete.
 3. Metal.
 4. Wood.
 5. Debris.
 6. Glass.
 7. Clay brick.
 8. Paper/Cardboard.
 9. Plastic.
 10. Gypsum.
 11. Paint.
 12. Carpet.
 13. Others as appropriate.
- C. Handling:
1. Clean materials which are contaminated prior to placing in collection containers. Deliver materials free of dirt, adhesives, solvents, petroleum contamination, and other substances deleterious to recycling process.
 2. Arrange for collection by or delivery to the appropriate recycling or reuse facility.
- D. Participate in re-use programs: identify local and regional re-use programs, including but not limited to non-profit organizations such as schools, local housing agencies, and public arts programs, that accept used materials. The following are examples for Contractor's information only.
1. National materials exchange network, such as CAL-MAX, a free service provided by various state and regional offices, designed to help businesses find markets for materials that traditionally would be discarded. The premise of the program is that material discarded by one business may be a resource for another business.

- a. Items and regions covered by materials exchange programs may vary. Contact the applicable regional materials exchange program. In California, contact CAL-MAX at (916) 255-2369.
2. Habitat For Humanity, a non-profit housing organization that rehabilitates and builds housing for low income families.
 - a. Sites requiring donated materials vary. Contact the national hotline (800) HABITAT.
- E. Rebates, tax credits, and other savings obtained for recycled or re-used materials accrue to Contractor.

3.2 ENVIRONMENTAL CONTROLS

- A. Protection of natural resources: Preserve the natural resources within the Project boundaries and outside the limits of permanent Work performed under this Contract in their existing condition or restore to an equivalent or improved condition as approved by Postal Service, upon completion of the Work.
 1. Confine demolition and construction activities to work area limits indicated on the Drawings and as directed by COR.
 - a. Temporary construction: As specified in Section 015000 - Temporary Facilities And Controls.
 - b. Demolition and salvage operations: As specified in Section 024119 - Selective Structure Demolition.
 - c. Disposal operations for demolished and waste materials that are not identified to be salvaged, recycled or reused:
 - 1) Remove debris, rubbish, and other waste materials resulting from demolition and construction operations, from site.
 - 2) No burning permitted.
 - 3) Transport materials with appropriate vehicles and dispose off-site to areas which are approved for disposal by governing authorities having jurisdiction.
 - 4) Avoid spillage by covering and securing loads when hauling on or adjacent to public streets or highways. Remove spillage and sweep, wash, or otherwise clean project site, streets, or highways.
 - 5) Comply with applicable federal, state and/or local regulations.
 2. Water resources as follows:
 - a. Comply with requirements of the National Pollutant Discharge Elimination System (NPDES) and the State Pollutant Discharge Elimination System (SPDES).
 - b. Oily substances: Prevent oily or other hazardous substances from entering the ground, drainage areas, or local bodies of water.
 - 1) Store and service construction equipment at areas designated for collection of oil wastes.
 - c. Mosquito abatement: Prevent ponding of stagnant water conducive to mosquito breeding habitat.
 - d. Prevent run-off from site during demolition and construction operations.
 3. Land resources: Prior to construction, identify land resources to be preserved within the Work area. Do not remove, cut, deface, injure, or destroy land resources including trees, shrubs, vines, grasses, top soil, and land forms without permission from Postal Service.
 4. Air Resources: Prevent creation of dust, air pollution, and odors.
 - a. Use water sprinkling, temporary enclosures, and other appropriate methods to limit dust and dirt rising and scattering in air to lowest practical level.
 - 1) Do not use water when it may create hazardous or other adverse conditions such as flooding and pollution.

- b. Do not use any hazardous chemicals on USPS property when it is a shared work space with USPS employees. If chemicals are authorized for use, store volatile liquids, including fuels and solvents, in closed containers.
- c. Properly maintain equipment to reduce gaseous pollutant emissions.
- d. Interior final finishes: Schedule construction operations involving wet products prior to packaged dry products to the greatest extent possible in accordance with Postal Service approved Solid Waste Management and Environmental Protection Plan.
- e. Temporary Ventilation:
 - 1) Provide adequate ventilation during and after installation of interior wet products and interior final finishes.
 - 2) Provide adequate ventilation of packaged dry products prior to installation. Remove from packaging and ventilate in a secure, dry, well-ventilated space free from strong contaminant sources and residues. Provide a temperature range of 60 degrees F minimum to 90 degree F maximum continuously during the ventilation period. Do not ventilate within limits of Work unless otherwise approved by the COR.
- f. Pre-occupancy ventilation: After final completion and prior to initial occupancy, provide adequate ventilation for minimum 5 days. Pre-occupancy ventilation procedures:
 - 1) Use supply air fans and ducts only.
 - 2) Temporarily seal exhaust ducts.
 - 3) Temporarily disable exhaust fans.
 - 4) Provide exhaust through operable windows or temporary openings.
 - 5) Provide temporary exhaust fans as required to pull exhaust air from deep interior locations. Stair towers may be used for exhausting air from the building during the temporary ventilation.
 - 6) After pre-occupancy ventilation and prior to final testing and balancing of HVAC system, replace air filters and make HVAC system fully operational.
- 5. Fish and Wildlife Resources: Manage and control construction activities to minimize interference with, disturbance of, and damage to fish and wildlife.
- 6. Noise Control: Perform demolition and construction operations to minimize noise. Perform noise producing work in less sensitive hours of the day or week as directed by Postal Service .
 - a. Repetitive, high level impact noise will be permitted only between the hours of 8:00 a.m. and 6:00 p.m. Do not exceed the following dB limitations:

<u>Sound Level in dB</u>	<u>Time Duration of Impact Noise</u>
70.....	More than 12 minutes in any hour
80.....	More than 3 minutes in any hour

- b. Provide equipment, sound-deadening devices, and take noise abatement measures that are necessary for compliance.

END OF SECTION

USPS Specification Last Revised: 10/1/2022

Attachment A

SUMMARY OF SOLID WASTE DISPOSAL AND DIVERSION

Project Name: _____ FMS Project Number: _____

Contractor Name: _____ License Number: _____

Contractor Address: _____

Solid Waste Material	Date Material Disposed/ Diverted	Amount Disposed/ Diverted (ton or cu. yd)	Municipal Solid Waste Facility (name, address, & phone number)	Recycling/Reuse Facility (name, address, & phone number)	Comments (if disposed, state why not diverted)
Asphalt					
Concrete					
Metal					
Wood					
Debris					
Glass					
Clay brick					
Paper/ Cardboard					
Plastic					
Gypsum					
Paint					
Carpet					
Other:					

Signature: _____ Date: _____

Attachment B

RESOURCE CONSERVATION AND RECOVERY ACT - PROJECT SUMMARY

Project Name: _____ FMS Project Number: _____
 Contractor Name: _____ License Number: _____
 Contractor Address: _____

1.0 EPA GUIDELINE ITEMS

A. Fly Ash:

1. Total dollar amount of concrete and cement provided for this project. \$_____.
2. Total dollar amount of concrete and cement containing fly ash provided for this project. \$_____.
3. Were there any technical impediments to increasing the amount of concrete and cement containing fly ash provided for this project? _____.
 a. If yes, please explain. _____

 _____.

B. Building Insulation Products:

1. Total dollar amount of building insulation products provided for this project. \$_____.
2. Total dollar amount of building insulation products containing recycled materials provided for this project. \$_____.
3. Were there any technical impediments to increasing the amount of building insulation products containing recycled materials provided for this project? _____.
 a. If yes, please explain. _____

 _____.

C. Carpet:

1. Total dollar amount of carpet provided for this project. \$_____.
2. Total dollar amount of carpet containing recycled materials provided for this project. \$_____.
3. Were there any technical impediments to increasing the amount of carpet containing recycled materials provided for this project? _____.
 a. If yes, please explain. _____

 _____.

D. Floor Tiles (resilient):

- 1. Total dollar amount of floor tile (resilient) provided for this project. \$_____.
- 2. Total dollar amount of floor tile (resilient) containing recycled materials provided for this project. \$_____.
- 3. Were there any technical impediments to increasing the amount of floor tile (resilient) containing recycled materials provided for this project? _____.

a. If yes, please explain. _____

E. Floor Tiles (ceramic):

- 1. Total dollar amount of floor tile (ceramic) provided for this project. \$_____.
- 2. Total dollar amount of floor tile (ceramic) containing recycled materials provided for this project. \$_____.
- 3. Were there any technical impediments to increasing the amount of floor tile (ceramic) containing recycled materials provided for this project? _____.

a. If yes, please explain. _____

F. Hydraulic Mulch:

- 1. Total dollar amount of hydraulic mulch provided for this project. \$_____.
- 2. Total dollar amount of hydraulic mulch containing recycled materials provided for this project. \$_____.
- 3. Were there any technical impediments to increasing the amount of hydraulic mulch containing recycled materials provided for this project? _____.

a. If yes, please explain. _____

G. Compost:

- 1. Total dollar amount of compost provided for this project. \$_____.
- 2. Total dollar amount of compost containing recycled materials provided for this project. \$_____.
- 3. Were there any technical impediments to increasing the amount of hydraulic mulch containing recycled materials provided for this project? _____.

a. If yes, please explain. _____

2.0 SPECIFICATIONS

NOT USED

3.0 SOLID WASTE PREVENTION

- A. Total dollar amount of solid waste disposed (landfill) for this project. \$_____.
- B. Total weight of solid waste disposed (landfill) for this project. \$_____.

4.0 RECYCLING

- A. Total dollar value of solid waste diverted from landfill and recycled or reused for this project. (Express as total dollar amount for solid waste disposal in landfill for equivalent type and amount of diverted waste.)
\$_____.
- B. Total weight of solid waste diverted from landfill and recycled or reused for this project. (Express as total weight for solid waste disposal in landfill for equivalent type and amount of diverted waste.)
Tons_____.

5.0 COMMENTS

- A. Comments and suggestions for increasing amount of recycled materials used in construction materials.

_____.
- B. Comments and suggestions for improving solid waste prevention and recycling efforts during construction.

_____.

Signature: _____ Date: _____

SECTION 017704

CLOSEOUT PROCEDURES AND TRAINING

PART 1 – GENERAL

1.1 MANUALS

- A. Purpose: Operation and maintenance manuals are for the training of, and use by, Postal Service employees in the operation and maintenance of the systems and related equipment as specified below. The manuals must consist of instruction on systems and equipment. A separate manual or chapter must be prepared for each of the following classes of equipment or system:
1. Landscaping.
 2. Roof system.
 3. Doors.
 4. Security system.
 5. Fire protection.
 6. Plumbing systems.
 7. Mechanical systems.
 8. Electrical systems.
 9. Miscellaneous building equipment and systems.
 10. Mechanization (for requirements for mechanization maintenance manuals, see Mechanization Specification M-5000).
- B. Content: Unless otherwise indicated, each chapter must contain the following, as applicable:
Introduction.
Table of contents.
Description of system (including design intent and considerations).
- C. Preparation: The outline below is intended as a general guide for preparing the manuals. The manuals must be prepared to provide for the optimum operation and maintenance of the various systems. The description of systems and general operating instructions for plumbing and electrical manuals may cover only complicated or unusual parts of these systems, such as sewage ejectors, transformers, high tension switchgear, and signal and alarm systems. Manufacturer's literature and data must be those of the actual equipment installed under contract for the particular facility. Further guidance is available in the ASHRAE Handbook, 1984, Systems Volume, Chapter 39, Mechanical Maintenance.
- D. Suggested Outline for Operation and Maintenance (O&M) Manuals: This is a suggested outline, with general requirements of O&M manuals. The outline is presented to indicate the extent of material to be covered and the individual items required in manuals for Mail Processing Facilities. The outline may be modified to suit specific installations; however, the purpose of the manual must be fulfilled. The manual is not intended to duplicate manufacturers' data, but proper references must be made in the text of the O&M manual to indicate that that information is applicable and where it is located.
1. Part I. Description and Design Intent
 - a. Introduction
 - 1) Provide a brief description of project and purpose of the maintenance manual. The following statements must be included: "Operation and maintenance of this equipment must be performed in accordance with this manual and posted instructions, subject to compliance with applicable technical guides and standards issued by USPS. It is recognized that minor changes in control points and settings will be required, based on actual operating experience, to correct varying conditions and improve operation. When such changes appear necessary, they must be submitted to the maintenance manager for

017704-1

consideration. Upon approval of any changes, the applicable portions of all copies of the manual and proposed instructions must be revised and reissued, and any change in operating procedure brought to the attention of all operating personnel."

- 2) "This manual is specifically developed to assist the Postal official in charge at the facility to operate and maintain the building systems and equipment. Manufacturers' recommendations set forth for certain components must be followed during the complete warranty period for that equipment."
 - 3) Contents of Manual. This portion of the introduction must explain that the manual is to contain complete operating, maintenance, and safety instructions for all equipment listed. It must also contain any other appropriate references as required to outline an explanation of the manuals and major categories of reference material required with the manuals.
- b. Table of Contents
- 1) The table of contents must list numbers and titles of chapters, sections, and main paragraphs, with their page numbers. Each volume in a set of manuals must contain its own table of contents. Publications containing 10 or more illustrations or tables must include a list of illustrations or tables, as applicable. These lists must show number, title, and page number of each illustration and table. Following is a typical table of contents:
 - a. Landscaping
 - 1.) Irrigation system
 - 2.) Lawns and grasses
 - 3.) Exterior plants
 - 4.) Plant maintenance
 - b. Roof System
 - 1.) Roof and flashing type
 - 2.) Local inspection (frequency and what is included)
 - 3.) Maintenance (when manufacturer performs, if USPS performs what methods compatible materials, etc.)
 - c. Doors
 - 1.) Overhead coiling doors
 - 2.) Folding closures
 - 3.) Sectional overhead doors
 - 4.) Impact traffic doors
 - 5.) Automatic entrance doors
 - 6.) Specialized hardware
 - d. Security Systems
 - 1.) CCTV system
 - 2.) Intrusion detection
 - 3.) Electronic article surveillance
 - 4.) Access control
 - e. Fire Protection System
 - 1.) Water supply and distribution
 - 2.) Exterior fire hydrants
 - 3.) Sprinklers
 - 4.) Fire Department connections
 - 5.) Fire extinguishers
 - 6.) Exit signs
 - f. Plumbing Systems
 - 1.) Potable water
 - 2.) Domestic hot water
 - 3.) Roof and sanitary drains
 - g. Mechanical Systems

017704-2

- 1.) Space conditioning
 - 2.) Heating
 - 3.) Central chilled water and distribution
 - 4.) HVAC instrumentation and controls
 - h. Electrical Systems
 - 1.) Incoming Service
 - 2.) Electrical power distribution
 - 3.) Lighting and lighting controls
 - 4.) Fire alarm
 - 5.) Emergency lighting unit
 - i. Miscellaneous Building Equipment
 - 1.) Postal Parcel Lockers
 - 2.) Floor mats
 - 3.) Dock equipment
 - 4.) Window Treatments
 - 5.) Elevators
 - 6.) Scales
 - 7.) Dust collectors
 - 8.) Vehicle maintenance equipment
2. Part II. Operating Sequence and Procedures
- a. Contents: Each chapter must describe the procedures necessary for Postal Service personnel to operate the system and equipment covered in that chapter.
 - b. Operating Procedures: The operating procedures must be divided into four subsections: Startup, Operation, Emergency Operation, and Shutdown.
 - 1) Startup: Give complete instructions for energizing the equipment and making initial settings and adjustments whenever applicable. If equipment is fully automatic, a statement to that effect is all that is required. If a specific sequence of steps must be performed, give step-by-step instructions in the proper sequence. If timing- (such as warm-up between power-on and adjustment) is important, clearly state the specific minimum time required at the proper point in the procedure. Refer to controls and indicators by panel; make references consistent with the nomenclature used in illustrations and tables of controls and indicators. If preliminary settings differ for different modes of operations, give procedures for each mode.
 - 2) Operation: Give detailed instructions in proper sequence for each mode of operation. When, for a given action on the part of the operator, alternate equipment responses are possible, give the appropriate operation reaction to each.
 - 3) Emergency Operation: If some functions of the equipment can be operated while other functions are disabled, give instructions for operations under these conditions. Include here only those alternate methods of operation (from normal) that the operator can follow when there is a partial failure or malfunctioning of components, or other unusual condition.
 - 4) Shutdown: Include instructions for stopping and securing the equipment after operation. If a particular sequence is required, give step-by-step instructions in that order.
3. Part III. Maintenance Instructions and Requirements
- a. Contents: Each chapter must describe the procedures necessary for Postal Service personnel to perform the maintenance on the systems and equipment covered in that chapter. Emphasis must be placed on the method of mechanical control of systems and equipment from a maintenance standpoint. References must be made, as appropriate, to drawings, schematics, and sequences of operation included as part of the construction Contract drawings and specifications that show piping and equipment arrangements and items of control. Prints of these

017704-3

drawings must be reduced to 11 inches x 17 inches for insertion in the manuals. Drawings must represent the "as-built" condition.

- b. Maintenance Procedures: The maintenance procedures must be divided into two categories: Preventive Maintenance and Corrective Maintenance.
 1. Preventive Maintenance
 - a. Provide a schedule for preventive maintenance. State, preferably in tabular form, the recommended frequency of performance for each preventive maintenance task (cleaning, inspection, and scheduled overhauls).
 - b. Provide instruction and schedules for all routine maintenance cleaning and inspection, with recommended lubricants.
 - c. If periodic inspection of equipment is required for operation, cleaning, or other reasons, indicate the items to be inspected and give the inspection criteria for, but not limited to, the following:
 - 1.) Motors
 - 2.) Controls
 - 3.) Filters
 - 4.) Heat exchangers
 2. Provide instruction for minor repairs or adjustments required for preventive maintenance routines. Minor repair and adjustment must be limited to repairs and adjustments that may be performed without special tools or test equipment and that require no special training or skills. Identify test points and give values for each.
- c. Corrective Maintenance
 1. Corrective Maintenance: Corrective maintenance instructions must be predicated upon a logical effect-to-cause troubleshooting philosophy and a rapid replacement procedure to minimize equipment downtime. Instructions and data must appear in the normal sequence of corrective maintenance, for example, troubleshooting first, repair and replacement of parts second, and then the parts list.
 2. Troubleshooting: This information must describe the general procedure for locating malfunctions and must give, in detail, any specific remedial procedures or techniques. The data shown are intended to isolate only the most common equipment deficiencies. Troubleshooting tables, charts, or diagrams may be used to present specific procedures. A guide to this type must be a three-column chart. The columns must be entitled Malfunction, Probable Cause, and Recommended Action. The information must be alphabetically arranged by component, and each component must, in turn, list deficiencies that may be expected. Each deficiency must contain one or more problems with a recommended correction.
 3. Repair and Replacement: Indicate the repair and replacement procedures most likely to be required in the maintenance of the equipment. Information included here must consist of step-by-step instructions for repair and replacement of defective items. Include all information required to accomplish repair or replacement, including information such as torque values. Identify all tools, special equipment, and materials that may be required. Identify uses for maintenance equipment. The paragraphs must contain headings to identify the topics covered.
 4. Safety Precautions: This subsection must comprise a listing of safety precautions and instructions to be followed before, during, and after repairs or adjustments are made or routine maintenance is performed.
- d. Manufacturers' Brochures: Include manufacturers' descriptive literature covering devices used in the system, together with illustrations, exploded views, and

017704-4

renewal parts lists. This section must also include special devices manufactured by the Contractor.

- e. Special Maintenance: Provide information of a maintenance nature covering warranty items that have not been discussed elsewhere.
 - f. Shop Drawings: Provide a copy of all approved shop drawings covering approval of equipment for the project with the manufacturers' brochures.
 - g. Spare Parts Lists: Include a recommended spare parts list for all equipment furnished for the project. The parts list must include a tabulation of descriptive data for all the electrical-electronic spare parts and all the mechanical spare parts proposed for each type of equipment or system. Each part must be properly identified by part number and manufacturer.
 - h. Warranty: Include a copy of the "special" or extended warranty in the operation and maintenance manual.
- E. Submittal, In both "hard" and electronic DVD or CD-ROM format (flash drives are not permitted):
- 1. Preliminary Submittal: Two draft copies of the completed manuscript for items in this outline must be submitted to the COR for review within 12 days after approval of equipment to be provided. One copy will be returned to the Contractor within 15 days after submittal and, if required, must be revised and resubmitted within 15 days.
 - 2. Final Submittal: four complete sets of manuals must be furnished to the COR not later than 30 days before completion of the project.
 - 3. Final Submittal must be accepted by the COR before training can begin.

1.2 POSTED OPERATING INSTRUCTIONS

- A. General. Operating instructions and diagrams must be prepared for posting near the equipment. Posted operating instructions must be photographic or equal non-fading reproductions framed under glass or encased in non-discoloring plastic and must be mounted in locations as directed. Copies of the posted operating instructions must also be used with the O&M manuals as a basis for training Postal Service personnel in the operation and maintenance of systems and related equipment installed under contract at the facility.
- B. Posted operating instructions must consist of simplified, consolidated equipment, control, and power diagrams graphically representing the entire system and actual equipment installed, including concise written instructions on how to start and stop systems, what settings and conditions are to be observed, and what control adjustments are to be made or maintained by the operation. Posted operating instructions must include, but are not limited to the following:
- 1. Boiler and burner controls.
 - 2. Refrigeration controls.
 - 3. Heating, ventilating, and air-conditioning controls for each system.
 - 4. Controls for dust collection systems.
 - 5. One-line schematic diagrams of water supply (plumbing).
 - 6. One-line diagrams of steam distribution and hot water and chilled water systems, including risers, main shutoff valves, balancing cocks, and the like.
 - 7. One-line isometric diagrams of sanitary drainage.

1.3 TRAINING

- A. The Contractor must train Postal Service personnel in the operation and maintenance of mechanical and electrical equipment. Coordination must be maintained with systems designers for developing the hours of instruction and scope of material to be covered. Training of Postal Service personnel must not begin until the COR has approved the final submittal copy of each O&M manual.
- B. Schedule Submittal: The proposed scope of training and materials and instruction schedule must be submitted for review and approval approximately 30 days before the scheduled completion of

the buildings. Mutually agreeable dates for training must be arranged with the COR, but the training must be completed before final acceptance of the facility.

- C. Scope of Training: Training must include classroom and on-the-job instructions by qualified installation and maintenance personnel having the necessary knowledge, experience, and teaching skills. The use of recording on digital media (DVD or CD discs; flash drives are not permitted) during the instruction period is required. Discs must be turned over to the COR after training has been completed.
- D. Time Period of Training: The minimum specific hours of training time required for each category of major equipment and systems is indicated below. Past experience indicates a workable ratio in the vicinity of approximately 25 percent classroom to 75 percent application, except that the ratio may be reversed for control systems. The COR must have the option of redistributing the training times, subject to the total time specified. Training must be presented on an 8-hour per day, 5-day per week schedule, with all reading assignments and review to be within this period.

1.4 TRAINING PERIOD

Item	Time (Hours)
1. Roofing	8
2. Special Doors	4
3. Dock Equipment	8
4. Security Equipment	16
5. Heating Plant Covers heat-generating equipment, such as heat exchangers, boilers, and burners; electric resistance heating; and related equipment, where applicable (including combustion testing), together with associated operation and safety controls.	24
6. Cooling Plant Covers the refrigeration plant, cooling tower (including water treatment), and related equipment, together with associated operating and safety controls.	24
7. Ventilation Covers air-handling units with heating and cooling coils, fans, and all other air-handling equipment, together with associated operating and limit controls.	8
8. Overall Control System Covers central control center, coordinating respective controls of heating, cooling, and ventilation systems, and shows how these controls work together to provide an integrated overall control of the complete air-conditioning system, both heating and cooling, as well as all other utility control systems.	16
9. Electrical System Covers all building services, lighting, lighting controls, and intercommunications, and security system.	32
10. Elevators Covers operation of the different types installed, demonstrations in the machine room on the various operating and control equipment installed, and explanation of the use of the electric circuit diagrams (of sufficient size) to ensure proper operation and assistance in troubleshooting.	4
11. Piping and Plumbing Includes, but is not limited to, domestic water supply, storm and sanitary drainage systems, cold-water supply systems, sprinkler systems, and the like.	8
12. Miscellaneous Includes, but is not limited to, vehicle maintenance equipment, fire protection and alarm equipment, dust collection systems, compressed air systems, automatic door	16

017704-6

operators, dock levelers, truck scales, data collection center, and all other equipment not specifically covered above.

13. Mechanization

See Mechanization Specification M-5000.

1.5 TRAINING PARTICIPATION SHEETS

- A. Submit to the COR sign-in sheets with the dates and names of all training participants. Training sheets must be reviewed and certified by an authorized facility manager.

1.6 OTHER CLOSEOUT SUBMITTALS

- A. Additional requirements for Systems Manuals, Operating Instructions, Training and other deliverables are contained in individual Specification Sections. All closeout requirements must be provided to and accepted by the COR prior to requesting final payment. Examples of additional closeout requirements include, but are not limited to, the following
1. Final Punch-List with all items certified as complete.
 2. In accordance with the terms and conditions of the contract provisions and clauses, including those concerning *Record "As Built" Drawings*, the Contractor shall submit certified As-Built Record Drawings and Specifications in the quantities and media specified.
 3. In accordance with the terms and conditions of the contract provisions and clauses, including those concerning *Warranty*, the Contractor shall submit all transferable guarantees and warranties for equipment, materials and installations furnished by any manufacturer, supplier, or installer.
 4. Signed Asbestos and Lead-Based Paint Certificate.
 5. RE-4 Certification of Accessibility (CoA) and Facility Accessibility Survey Report.
 6. Material Safety Data Sheets.
 7. Signed and sealed Contractor Release of Claims.

PART 2 – PRODUCTS

NOT USED

PART 3 – EXECUTION

NOT USED

END OF SECTION

USPS Specification Last Revised: 10/1/2022

017704-7

SECTION 024113

SELECTIVE SITE DEMOLITION

PART 1 - GENERAL

1.1 SUMMARY

A. Section Includes:

1. Demolition of designated site structures, retaining walls, fences, and foundations.
2. Demolition and removal of pavements, curbs and gutters, drainage structures, drainage pipe, utilities, site signs, and landscaping.
3. Disconnecting and capping or removal of identified utilities.
4. Removal of underground tanks and piping.
5. Filling voids in subgrade created as a result of removals or demolition.
6. Disposal of demolished materials.

B. Related Documents: The Contract Documents, as defined in Section 011000 - Summary of Work, apply to the Work of this Section. Additional requirements and information necessary to complete the Work of this Section may be found in other Documents.

C. Related Sections:

1. Section 013543 - Environmental Procedures: Recycling and reuse of waste materials.
2. Section 015000 - Temporary Facilities and Controls: Temporary protection and barriers. Removal and disposal of demolished materials. Coordination of temporary utilities.
3. Section 024119 - Selective Structure Demolition.
4. Section 311000 - Site Clearing: Clearing outside periphery of structures.
5. Section 312000 - Earth Moving: Fill material.
6. Section 312300 - Excavation and Fill: Earthwork for structures, utilities, and pavement.

1.2 QUALITY ASSURANCE

A. Regulatory Requirements:

1. Conform to applicable local code for demolition of structures, safety of adjacent buildings and structures, dust control and runoff control.
2. Obtain required permits and licenses from authorities having jurisdiction. Pay associated fees including disposal charges.
3. Notify affected utility companies before starting work and comply with utility company requirements.
4. Do not close or obstruct roadways, sidewalks or fire hydrants without permits.
5. Barricade and mark hazards as necessary.
6. Conform to applicable regulatory procedures when discovering hazardous or contaminated materials. Notify Contracting Officer immediately upon discovery of hazardous or contaminated materials. Do not commence removals, remediation, or abatement without authorization from Contracting Officer.

1.3 PROJECT CONDITIONS

A. Existing Conditions:

1. Structures indicated for demolition will be discontinued in use and vacated prior to start of Work.
2. United States Postal Service assumes no responsibility for condition of structures to be demolished.

3. Unless otherwise indicated in the Contract Documents or specified by the Contracting Officer, remove items of salvageable value to Contractor from project site and structure. Storage or sale of removed items on project site not permitted.
4. Burning or fires of any nature not permitted.
5. Do not bring explosives on site without written approval of authorities having jurisdiction. Such written approval will not relieve Contractor of total responsibility for injury to persons or for damage to property due to blasting operations. Comply with governing regulations for use of explosives. Notify company of procedures and schedule in advance of explosive use.

PART 2 - PRODUCTS

2.1 FILL MATERIALS

- A. Refer to in Section 312000.

PART 3 - EXECUTION

3.1 EXAMINATION

- A. Section 017300 - Execution: Verification of existing conditions before starting work.
- B. Site Verification of Conditions: Verify that field measurements, surfaces, substrates, and conditions are as required, and ready to receive Work.
 1. Locate existing utilities, conduit and piping using "Ground Penetrating Radar (GPR)" detection.
- C. Report in writing to Contracting Officer prevailing conditions that will adversely affect satisfactory execution of the Work of this Section. Do not proceed with Work until unsatisfactory conditions have been corrected.
- D. By beginning Work, Contractor accepts conditions and assumes responsibility for correcting unsuitable conditions encountered at no additional cost to United States Postal Service.

3.2 PREPARATION

- A. Provide, erect, and maintain erosion control devices, dust control measures, temporary barriers, and security devices at locations indicated on Drawings and as specified in Section. 015000.
- B. Protect appurtenances and structures which are not indicated to be demolished. Repair damage caused by demolition operations at no additional cost to United States Postal Service.
- C. Prevent movement or settlement of adjacent structures. Provide bracing and shoring as required.
- D. Mark location of utilities. Protect and maintain, in safe and operable condition, utilities to remain. Provide temporary services during interruptions to existing utilities acceptable to governing authorities and United States Postal Service.
- E. Clear areas around items and structures indicated to be demolished as specified in Section 311000.

3.3 CONSTRUCTION

- A. Demolition Requirements:

024113 - 2

1. Conduct demolition to minimize interference with adjacent structures or pavements.
 2. Stop operations immediately if adjacent structures appear to be in danger. Notify Contracting Officer immediately. Do not resume operations until directed by Contracting Officer.
 3. Conduct operations with minimum interference to public or private access. Maintain access and egress at all times.
 4. Obtain written permission from adjacent property owners when demolition equipment will traverse, infringe upon, or limit access to their property.
 5. Sprinkle soil and demolition work area with water to minimize dust. Provide hoses and water connections for this purpose.
 6. Comply with governing regulations pertaining to environmental protection.
 7. Clean adjacent structures and improvements of dust, dirt, and debris caused by demolition operations. Return adjacent areas to condition existing prior to start of work.
- B. Demolition:
1. Disconnect and remove designated utilities within demolition areas.
 2. Notify inhabitants of on-site structures of intent to demolish two weeks prior to demolition and verify property is vacated prior to starting demolition.
 3. Verify structures are unoccupied; then demolish structures completely and remove from site using methods as required to complete work within limitations of governing regulations. Small structures may be removed intact when acceptable to Contracting Officer and authorities having jurisdiction.
 4. Proceed with demolition in systematic manner, from top of structure to ground.
 5. Locate demolition equipment and remove materials using procedures to prevent excessive loading to supporting walls, floors, or framing.
 6. Demolish concrete and masonry in small sections. Break up concrete slabs-on-grade that are 2 or more feet below proposed subgrade.
 7. Demolish and remove below grade construction and concrete slabs on grade to a minimum depth of two feet below proposed subgrade.
- C. Filling Voids:
1. Completely fill below grade areas and voids existing or resulting from demolition or removal of structures (pits, wells, cisterns, etc.) using approved select fill materials consisting of stone, gravel, and sand free from debris, trash, frozen materials, roots, and other organic matter.
 2. Remove standing water, frost, frozen, or unsuitable material, trash, and debris from areas to be filled before fill placement.
 3. Place fill materials in horizontal layers and compact each layer at optimum moisture content of fill material to proposed density as specified in Section. 312000.
 4. Grade surface to match adjacent grades and to provide flow of surface drainage after fill placement and compaction.
- D. Disposal of Demolished Materials:
1. Collect, recycle, reuse and dispose of demolished materials as specified in Section 013543-Environmental Procedures and as approved by the U.S. Postal Service in the Solid Waste Management and Environmental Protection Plan.

END OF SECTION

USPS MPF Specification Last Revised: 10/1/2022

SECTION 031000

CONCRETE FORMING AND ACCESSORIES

PART 1 - GENERAL

1.1 SUMMARY

- A. Section Includes
 - 1. Formwork for cast-in place concrete, with shoring, bracing and anchorage.
 - 2. Openings for other work.
 - 3. Form accessories.
 - 4. Form stripping.
- B. Related Documents: The Contract Documents, as defined in Section 011000 - Summary of Work, apply to the Work of this Section. Additional requirements and information necessary to complete the Work of this Section may be found in other documents.
- C. Related Sections:
 - 1. Section 032000 - Concrete Reinforcement: Coordination between formwork and reinforcement.
 - 2. Section 033000 - Cast-in-Place Concrete: Supply of concrete accessories for placement by this section.

1.2 REFERENCES

- A. American Concrete Institute (ACI) Codes and Standards latest editions:
 - 1. ACI 301 - Structural Concrete for Buildings.
 - 2. ACI 318 - Building Code Requirements for Reinforced Concrete.
 - 3. ACI 347 - Recommended Practice for Concrete Formwork.
 - 4. []
- B. United States Department of Commerce Product Standard (PS):
 - 1. PS 1 - Construction and Industrial Plywood.

1.3 SUBMITTALS

- A. Section 013300 - Submittal Procedures: Procedures for submittals.
 - 1. Product Data: Provide data on void form materials and installation requirements. Submit data on form-coating materials.
 - 2. Shop Drawings: Indicate pertinent dimensions, materials, required installation and removal of bracing, shoring [, and reshoring] and arrangement of joints and ties.

1.4 QUALITY ASSURANCE

- A. Perform Work in accordance with ACI 347.
- B. Where necessary, design formwork, shoring [, and reshoring] under direct supervision of a Professional Engineer experienced in design of formwork and licensed in State where Project is located.

1.5 DELIVERY, STORAGE, AND HANDLING

- A. Section 016000 - Product Requirements: Transport, handle, store, and protect products.
- B. Deliver void forms and installation instructions in manufacturer's packaging.
- C. Store off ground in ventilated and protected manner to prevent deterioration from moisture.

1.6 ENVIRONMENTAL REQUIREMENTS

- A. Environmental Impact:
 - 1. Formwork: Reuse forms to greatest extent possible without damaging structural integrity of concrete and without damaging aesthetics of exposed concrete.

PART 2 - PRODUCTS

2.1 WOOD FORMS

- A. Forms for Exposed Finish Concrete: Plywood panels, to provide continuous, straight, smooth, exposed surfaces. Furnish in largest practicable sizes to minimize number of joints and to conform to joint system shown on drawings.
 - 1. Plywood complying with U.S. Product Standard PS-1 "B-B (Concrete Form) Plywood," Class I, Exterior Grade or better, mill-oiled and edge-sealed, with each piece bearing legible inspection trademark.
- B. Forms for Unexposed Finish Concrete: Plywood, lumber, metal, or other acceptable material. Provide lumber dressed on at least 2 edges and one side for tight fit.
- C. Lumber: Construction grade; with grade stamp clearly visible.

2.2 PREFABRICATED FORMS

- A. Preformed Steel Forms: Minimum 16 gage, well matched, tight fitting, stiffened to support weight of concrete without deflection detrimental to tolerances and appearance of finished surfaces.
- B. Void Forms (Carton Forms): Moisture resistant treated paper faces, biodegradable, structurally sufficient to support weight of wet concrete mix until initial set. Thickness indicated on drawings.
- C. Tubular Column Type: Metal or fiberglass-reinforced plastic. Provide units with sufficient wall thickness to resist wet concrete loads without deformation.
- D. Forms for Textured Finish Concrete: Units of face design, size, arrangement, and configuration to match Architect's control sample. Provide solid backing and form supports to ensure stability of textured form liners.

2.3 ACCESSORIES

- A. Form Ties: Factory-fabricated, removable or snap-off type, metal, of fixed or adjustable length as applicable, with cone ends. Designed to prevent form deflection and to prevent spalling concrete upon

removal. Back break dimension, 1-1/2 inch from exposed concrete surface. Provide ties that, when removed, will leave holes not larger than 1 inch diameter in concrete surface.

- B. Form Release Agent: 100 percent biodegradable colorless agent which will not stain concrete, or absorb moisture, or impair natural bonding or color characteristics of subsequent coatings intended for use on concrete surfaces. Zero VOC.
 - 1. Envirolux by Conspec, Kansas City, KS, (800) 348-7351 or (913) 287-1700.
 - 2. SMD-10 Soy Form Release by Strategic Market Development (800) 959-1071 or (815) 935-0863.
 - 3. Bio-Form by Leahy-Wolf, Franklin Park, IL, (888) 873-5327 or (847) 455-5710.
 - 4. Section 016000 - Product Requirements: Product options and substitutions. Substitutions: Permitted.
- C. Corners: Chamfered, wood strip 3/4 x 3/4 inch size; maximum possible lengths.
- D. Dovetail Anchor Slot: Galvanized steel, 22 gage thick, foam filled, release tape sealed slots, anchors for securing to concrete formwork.
- E. Nails, Spikes, Lag Bolts, Through Bolts, and Anchorages: Sized as required, of sufficient strength and character to maintain formwork in place while placing concrete.
- F. Waterstops (Rubber/PVC): Rubber or Polyvinyl chloride, minimum 1,750 tensile strength, minimum 50 degrees F to plus 175 degrees F working temperature range, width as indicated on Drawings, maximum possible lengths, ribbed profile, preformed corner sections, heat welded jointing.

PART 3 - EXECUTION

3.1 EXAMINATION

- A. Section 017300 - Execution: Verification of existing conditions before starting work.
- B. Verification of Conditions: Verify that field measurements, surfaces, and conditions are as required, and ready to receive Work.
 - 1. Verify lines, levels and centers before proceeding with formwork. Ensure that dimensions agree with Drawings.
- C. Report in writing to Contracting Officer prevailing conditions that will adversely affect satisfactory execution of the Work of this Section. Do not proceed with Work until unsatisfactory conditions have been corrected.
- D. By beginning Work, Contractor accepts conditions and assumes responsibility for correcting unsuitable conditions encountered at no additional cost to United States Postal Service.

3.2 EARTH FORMS

- A. Hand trim sides and bottom of earth forms. Remove loose soil prior to placing concrete.

3.3 FORMWORK INSTALLATION

- A. Install formwork, shoring and bracing to achieve design requirements, in accordance with requirements of ACI 347R.
- B. Provide bracing to ensure stability of formwork. Shore or strengthen formwork subject to overstressing by construction loads.

- C. Arrange and assemble formwork to permit dismantling and stripping. Do not damage concrete during stripping. Permit removal of remaining principal shores upon approval by the Professional Engineer responsible for their design.
- D. Align joints and make watertight. Furnish in largest available sizes to minimize number of joints and to conform to joint system indicated on Drawings.
- E. Obtain approval from the Engineer or Architect before framing openings in structural members which are not indicated on Drawings.
- F. Provide chamfer strips on external corners of concrete members, to produce uniform, smooth lines and tight edge joints.
- G. Install void forms in accordance with manufacturer's published instructions. Protect forms from moisture or crushing.

3.4 FORM RELEASE AGENT APPLICATION

- A. Apply form release agent on formwork in accordance with manufacturer's published instructions.
- B. Apply prior to placement of reinforcing steel, anchoring devices, and embedded items.
- C. Do not apply form release agent where concrete surfaces will receive special finishes or applied coverings which are effected by agent. Soak inside surfaces of untreated forms with clean water. Keep surfaces coated prior to placement of concrete.

3.5 INSERTS, EMBEDDED PARTS, AND OPENINGS

- A. Provide formed openings where required for items to be embedded in passing through concrete work.
- B. Locate and set in place items which will be cast directly into concrete.
- C. Coordinate with work of other sections in forming and placing openings, slots, recesses, sleeves, bolts, anchors, other inserts, and components of other Work.
- D. Install accessories in accordance with manufacturer's published instructions, straight, level, and plumb. Ensure items are not disturbed during concrete placement.
- E. Provide temporary ports or openings in formwork where required to facilitate cleaning and inspection. Locate openings at bottom of forms to allow flushing water to drain.
- F. Close temporary openings with tight fitting panels, flush with inside face of forms, and neatly fitted so joints will not be apparent in exposed concrete surfaces.
- G. Install waterstops in accordance with manufacturer's published instructions continuous without displacing reinforcement. Seal joints watertight.

3.6 FORM CLEANING

- A. Clean forms as erection proceeds, to remove foreign matter within forms.
- B. Clean formed cavities of debris prior to placing concrete.

- C. Flush with water or use compressed air to remove remaining foreign matter. Ensure that water and debris drain to exterior through clean-out ports.
- D. During cold weather, remove ice and snow from within forms. Do not use de-icing salts. Do not use water to clean out forms, unless formwork and concrete construction proceed within heated enclosure. Use compressed air or other means to remove foreign matter.

3.7 CONSTRUCTION

- A. Site Tolerances:
 - 1. Construct formwork to maintain tolerances required by ACI 301 and ACI 347.
 - 2. Camber slabs and beams 1/4 inch per 10 feet in accordance with ACI 301.

3.8 FIELD QUALITY CONTROL

- A. Section 014000 - Quality Requirements: Field inspection and testing.
- B. Inspect erected formwork, shoring [, and reshoring], and bracing to ensure that work is in accordance with formwork design, and that supports, fastenings, wedges, ties, and items are secure.

3.9 FORM REMOVAL

- A. Do not remove forms or bracing until concrete has gained sufficient strength to carry its own weight and imposed loads.
- B. Do not remove shoring without approval from the Professional Engineer responsible for their design.
- C. Loosen forms carefully. Do not wedge pry bars, hammers, or tools against finish concrete surfaces scheduled for exposure to view.
- D. Store removed forms in manner that surfaces to be in contact with fresh concrete will not be damaged. Discard damaged forms.

END OF SECTION

USPS MPF Specification Last Revised: 10/1/2022

SECTION 032000

CONCRETE REINFORCEMENT

PART 1 - GENERAL

1.1 SUMMARY

- A. Section Includes:
 - 1. Reinforcing steel bars.
 - 2. Steel wire mesh.
 - 3. Reinforcement accessories.
- B. Related Documents: The Contract Documents, as defined in Section 011000 - Summary of Work, apply to the Work of this Section. Additional requirements and information necessary to complete the Work of this Section may be found in other documents.
- C. Related Sections:
 - 1. Section 316329 - Drilled Concrete Piers and Shafts: Reinforcement for drilled pier foundations.
 - 2. Section 031000 - Concrete Forming and Accessories: Coordination between formwork and reinforcing.
 - 3. Section 033000 - Cast-in-Place Concrete: Coordination between concrete placement and reinforcing.

1.2 REFERENCES

- A. American Concrete Institute (ACI):
 - 1. ACI 301 - Structural Concrete for Buildings.
 - 2. ACI 318 - Building Code Requirements For Reinforced Concrete.
 - 3. ACI SP-66 - American Concrete Institute - Detailing Manual.
- B. American Society for Testing and Materials (ASTM):
 - 1. ASTM A 184 - Fabricated Deformed Steel Bar Mats for Concrete Reinforcement.
 - 2. ASTM A 615 - Deformed and Plain Billet Steel Bars for Concrete Reinforcement.
 - 3. ASTM A 704 - Welded Steel Plain Bar or Rod Mats for Concrete Reinforcement.
- C. American Welding Society (AWS):
 - 1. AWS D1.4 - Structural Welding Code for Reinforcing Steel.
- D. Concrete Reinforcing Steel Institute (CRSI):
 - 1. CRSI - Manual of Practice.
 - 2. CRSI 63 - Recommended Practice For Placing Reinforcing Bars.
 - 3. CRSI 65 - Recommended Practice For Placing Bar Supports, Specifications and Nomenclature.

1.3 SUBMITTALS

- A. Section 013300 – Submittal Procedures: Procedures for submittals.
 - 1. Shop Drawings: Indicate bar sizes, spacings, locations, and quantities of reinforcing steel [and wire fabric, bending and cutting schedules, and supporting and spacing device. Include special reinforcement required for openings through concrete structures.
 - 2. Assurance/Control Submittals;
 - a. Manufacturer's Certificate: Certify that products meet or exceed specified requirements.

- b. Submit certified copies of mill test report of reinforcement materials analysis.
- c. Welder's Certificates.

1.4 QUALITY ASSURANCE

- A. Perform Work in accordance with CRSI 63, 65 and Manual of Practice ACI 301, ACI SP-66, ACI 318, and ASTM A 184.
- B. Design reinforcement under direct supervision of a Professional Structural Engineer experienced in design of this work and licensed in the State where the Project is located.
- C. Welders' Certificates: Submit certificate, certifying welders employed on the Work, verifying AWS qualification within the previous 12 months.

PART 2 - PRODUCTS

2.1 STEEL REINFORCEMENT

- A. Reinforcing Steel: ASTM A 615, 60 ksi yield grade; deformed billet steel bars, unfinished.
- B. Reinforcing Steel Mat: ASTM A 704, ASTM A 615, 60 ksi yield grade; steel bars or rods, unfinished.
- C. Reinforcing Steel Mesh: ASTM A185; 6X6, w 1.4 X w 1.4.
- D. Dowels at Construction Joints: 1/4" x 4.5" Diamond Dowels by PNA Construction Technologies or approved equal.

2.2 ACCESSORIES

- A. Tie Wire: Minimum 16 gage annealed type.
- B. Chairs, Bolsters, Bar Supports, Spacers: Sized and shaped for strength and support of reinforcement during concrete placement conditions including load bearing pad on bottom to prevent vapor barrier puncture.
- C. Special Chairs, Bolsters, Bar Supports, Spacers Adjacent to Weather Exposed Concrete Surfaces: Plastic coated steel type(CRSI, Class 1) or stainless steel protected(CRSI, Class 2); size and shape as required.

2.3 FABRICATION

- A. Fabricate concrete reinforcing in accordance with ACI SP-66 and ACI 318.
- B. Weld reinforcement in accordance with AWS D1.4.
- C. Locate reinforcing splices not indicated on drawings, at point of minimum stress. Review location of splices with Contracting Officer.

PART 3 - EXECUTION

3.1 EXAMINATION

- A. Section 017300 - Execution: Verification of existing conditions before starting work.
- B. Verification of Conditions: Verify that field measurements, surfaces, and conditions are as required, and ready to receive Work.
- C. Report in writing to Contracting Officer prevailing conditions that will adversely affect satisfactory execution of the Work of this Section. Do not proceed with Work until unsatisfactory conditions have been corrected.
- D. By beginning Work, Contractor accepts conditions and assumes responsibility for correcting unsuitable conditions encountered at no additional cost to United States Postal Service.

3.2 PLACEMENT

- A. Place, support and secure reinforcement against displacement. Do not deviate from required position.
- B. Do not displace or damage vapor barrier.
- C. Accommodate placement of formed openings.
- D. Maintain concrete cover around reinforcing in accordance with ACI 318.

3.3 FIELD QUALITY CONTROL

- A. Section 014000 - Quality Requirements: Field inspection.
- B. Inspect reinforcing locations, bar types and sizes, wire ties, and welding (if applicable).

END OF SECTION

USPS MPF Specification Last Revised: 10/1/2022

SECTION 033000

CAST-IN-PLACE CONCRETE

PART 1 - GENERAL

1.1 SUMMARY

- A. Includes all labor, materials and appliances, and perform all operations in connection with the installation of Concrete Work, and all related work incidental to the completion thereof, as shown on the drawings, complete, in strict accordance with the drawings and as specified herein. Section Includes:
1. Cast-in-place (CIP) concrete in building frame elements, walls, foundations, foundation walls, slabs-on-grade, and mechanical equipment pads.
 2. Finishing of concrete floor slabs and toppings. Concrete liquid surface treatment, sealer, and slip-resistant coatings.
 3. Expansion and contraction, control joints in CIP concrete.
 4. Concrete curing and protection.
 5. Non-shrink grout including installation and forming.
 6. Testing related services.
- B. Related Documents: The Contract Documents, as defined in Section 011000 - Summary of Work, apply to the Work of this Section. Additional requirements and information necessary to complete the Work of this Section may be found in other Documents and References in Section 1.2.
- C. Related Sections: Related work specified elsewhere includes but may not be limited to
1. Section 031000: Concrete Forming and Accessories
 2. Section 032000: Concrete Reinforcement

1.2 REFERENCES

- A. American Concrete Institute (ACI) Codes and Standards latest editions:
1. ACI 117, "Standard Specification for Tolerances for Concrete Construction and Materials."
 2. ACI 301, "Specification for Structure /Concrete."
 3. ACI 302.1R, "Guide for Concrete Floor and Slab Construction."
 4. ACI 304R, "Guide for Measuring, Mixing, Transporting, and Placing Concrete."
 5. ACI 305, "Hot Weather Concreting."
 6. ACI 306, "Cold Weather Concreting."
 7. ACI 311, "Recommended Practice for Concrete Inspection."
 8. ACI 315, "Details and Detailing of Concrete Reinforcement."
 9. ACI 318, "Building Code Requirements for Structural Concrete."
 10. ACI 347, "Guide to Formwork for Concrete."
- B. American Welding Society (AWS)
1. AWS D1.4, "Structural Welding Code Reinforcing."
- C. American Society for Testing and Materials (ASTM).
1. ASTM A615, "Standard Specification for Deformed and Plain Billet-Steel Bars for Concrete Reinforcement."
 2. ASTM C33, "Standard Specification for Concrete Aggregates."
 3. ASTM C94, "Standard Specification for Ready-Mixed Concrete."
 4. ASTM C150, "Standard Specification for Portland Cement."

5. ASTM C260, "Standard Specification for Air Entraining Admixtures for Concrete."
 6. ASTM C309, "Standard Specification for Liquid Membrane-Forming Compounds for Curing Concrete."
 7. ASTM C494, "Standard Specification for Chemical Admixtures for Concrete."
 8. ASTM C618, "Standard Specification for Fly Ash and Raw or Calcined Natural Pozzolan for Use as a Mineral Admixture in Portland Cement Concrete."
 9. ASTM C989, "Standard Specification for Ground Granulated Blast-Furnace Slag for Use in
- D. Concrete Reinforcing Steel Institute (CRSI),
1. CRSI "Manual of Standard Practice."

1.3 SUBMITTALS

- A. Section 013300 - Submittal Procedures: Procedures for submittals.
1. Product Data: Provide data technical, testing, and source for mix design materials and additives, steel reinforcement, joint sealant [, and other products as specified on the drawings.]
 2. Shop Drawings: Provide shop drawings for reinforcement, layout, detailing, and placing prior to fabrication, site delivery, and installation.
 - a. Mix design submittals.
 - b. Rebar placing drawings (ACI 315, "Detailing Manual SP-66-(04)" or CRSI "Manual of Standard Practice MSP-2-81"): Show bar sizes, bending, placing, spacing, locations, and quantities of reinforcing and wire fabric and supporting and spacing accessories. Provide steel order lists including bending and cutting details for all reinforcement shown on the structural design drawings.
 - c. Form construction details, including jointing, special formed joints or reveals, location and pattern of form tie placement [, and other items that affect exposed concrete visually.]
 - d. Calculations and layout drawings for formwork, shoring and/or reshoring [, and other submittals indicated on the drawings.] Work shall be prepared and signed and sealed by a Professional Engineer.
 3. Assurance/Control Submittals:
 - a. Test Reports: Prepare reports in conformance with Section 014000 - Quality Requirements
 - b. Submit laboratory test reports for concrete materials and mix designs for each strength and type of concrete proposed for use.
 - c. Certificates: Manufacturer's certificate that Products meet or exceed specified requirements.
 4. Delivery Tickets:
 - a. Copies of delivery tickets for each load of concrete delivered to site.
 - b. Indicate on each ticket the exact time that the mix is batched.
 - c. Mix identification number on ticket shall match number on submitted and approved mix design
 - d. Submit copies to Testing Laboratory for verification of compliance with placing time.

1.4 QUALITY ASSURANCE

- A. Perform work in accordance with the Codes and Standards referenced in section 1.2 of this specification.
1. Provide qualification data for manufacturers and installers.
- B. Pre-Installation Conference:
1. Conduct a pre-installation conference prior to commencing Work of this Section.
- C. Crack Prevention:
1. Submit quality control plan that incorporates provisions for concrete crack prevention at least 60 days prior to any slab on grade placement. The quality control plan shall be reviewed in the pre-installation conference. If wire mesh is used, the construction manager shall employ a full time 3rd party inspector to

monitor this element during all concrete placement operations to ensure that mesh is maintained in the proper position. This inspection is in addition to the other concrete material testing.

1.5 DELIVERY, STORAGE, AND HANDLING

- A. Section 016000 - Product Requirements: Transport, handle, store, and protect Products.
- B. Deliver materials in unopened containers with labels identifying contents.
- C. Store powdered materials in dry area and in manner to prevent damage. Protect liquid materials from freezing or exceeding maximum storage temperatures set by product manufacturer.

1.6 ENVIRONMENTAL REQUIREMENTS

- A. Resource Management:
 - 1. Recycled Content:
 - a. Concrete: Fly ash may be used as a substitute for a maximum of 25 percent of Portland cement unless otherwise specified by the engineer.
 - b. Concrete: Ground granulated blast furnace slag (GGBFS) may be used as a substitute for a maximum of 30 percent of Portland cement.

PART 2 - PRODUCTS

2.1 MANUFACTURERS

- A. Subject to compliance with project requirements, manufacturers offering Products which may be incorporated in the Work include the following:
 - 1. Applied Concrete Technology, Inc., Post Office Box 548, Grayslake, IL 60030, Toll Free: 800-228-6694, Phone: 847-548-2444, Fax: 847-548-2555. www.protecrete.com
 - 2. The Euclid Chemical Company, 19218 Redwood Road, Cleveland, OH 44110, Phone: 216-1-9222, Toll Free: (800) 321-7628, Fax: 216-531-9596 www.euclidchemical.com.
 - 3. Fortifiber Corporation, 419 W. Plumb Lane, Reno, NV 89509, Toll Free: 800-773-4777, Fax: 775-333-6411, Website: www.fortifiber.com.
 - 4. ChemRex Inc., Shakopee, Minnesota 55379, Toll Free: 800-433-9517, Fax: 800-496-6067.
 - 5. BASF Construction Chemicals North America (former Master Builders), 23700 Chagrin Boulevard, Cleveland, OH 44122, Phone: 216-839-7500, Fax: 216-839-8821.
 - 6. W.R. Meadows, Inc., PO Box 338, Hampshire, Illinois 60140-0338, Toll Free: 800-342-5976, Phone: 847-683-4500.
 - 7. Reef Industries, 9209 Almeda Genoa, Houston, Texas 77075, Phone: 713-507-4251, Toll Free: 800-231-6074, Fax: 713-507-4295.
 - 8. Stego Industries LLC, 27442 Calle Arroyo Suite A, San Juan, Capistrano, CA 92675, Phone: 877-464-7834, Fax: 949-493-5165, www.stegoindustries.com.
 - 9. L & M Construction Chemicals, Inc. 14851 Calhoun Rd., Omaha, NE 68152-1140; Phone: 402-453-6600, Fax: 402-453-0244.
 - 10. Curecrete Chemical Company, Inc., 1203 W. Spring Creek Pl., Springville, UT Phone: 801- 489-5663.
 - 11. Midwest Floor Care Inc., 17202 Princeton Rd, Adams, NE 68301, Phone: 402-788-2820.
 - 12. General Resource Technology, Inc., 2978 Center Court, Eagan, MN 55121, Phone: 800-324-8154, Fax: 651-454-4252, www.grtinc.com.
- B. Section 016000 - Product Requirements: Product options and substitutions. Substitutions: Permitted.

2.2 CONCRETE MATERIALS

- A. Portland Cement: ASTM C150 – Type [] [supplement with] [fly ash] [ground granulated blast-furnace slag].
- B. Liquid admixtures: The following admixtures are permitted when approved in writing prior to use or are required as specified herein and shall be used in strict accordance with the manufacturer's specifications or recommendations:
 - 1. Calcium chloride: Conform to ACI 301. The water soluble chloride ion level shall not exceed 0.3 percent by weight of cement.
 - 2. Air-entraining admixtures: ASTM C260 for steel hard trowel interior slab finish, do not use air entrainment admixtures.
 - 3. Water-reducing admixtures: Conform to ASTM C494, Type A.
 - 4. Water-reducing/accelerating admixtures: Conform to ASTM C494, Type C or E.
 - 5. Water-reducing/retarding admixtures: Conform to ASTM C494, Type D.
 - a. High-range/water-reducing (HRWR) admixtures: Conform to ASTM C494, Type F or G super plasticizers. HRWR admixture shall be used in concrete with a maximum water/ cement ratio of 0.50 or less.
 - 6. Fly ash: Conform to ASTM C618. The use of a quality fly ash will be permitted as a cement-reducing admixture (minimum 15 percent and maximum 25 percent) unless otherwise restricted by the engineer. Fly ash used in concrete shall be from a single source and of a single class in combination with Portland cement of a single source and single class unless otherwise approved by the Engineer.
 - 7. Granulated Blast Furnace Slag is an alternative to fly ash and shall conform to ASTM C989 Grade 100 Or 120. Granulated blast furnace slag may be used as a substitute for a maximum of 30 percent of Portland cement.
- C. Aggregates:
 - 1. Normal-weight concrete - ASTM C33.
 - 2. Light-weight concrete – ASTM C330.
 - 3. Aggregates shall be from a single source.
- D. Water:
 - 1. Clean, potable, and free of injurious amounts of oil, acid, alkali, organic or other deleterious matter not detrimental to concrete; drinkable.

2.3 GROUT/MORTARS

- A. Cement grout: Conform to ASTM C387 "Dry packaged mixtures".

2.4 CURING/SEALING/HARDENERS

- A. Dissipating liquid membrane-forming compounds for curing concrete; Conform to ASTM C309, Type 1. Curing compound shall be compatible with floor sealer or finish used. Low VOC.
- B. Method of curing shall be approved by the finish flooring applicator where finishes are indicated.

- C. Exterior Sealers: applied to horizontal concrete surfaces permanently exposed to salts, deicer chemicals and moisture, including parking decks. The manufacturer shall provide a five-year labor and materials warranty on performance of the sealer. Sealer shall be compatible with the curing compound used.

2.5 JOINTS AND EMBEDDED ITEMS:

- A. Construction and Contraction Joints: Sealant shall be two-part semi-rigid epoxy and shall have minimum Shore A Hardness of 80 when measured with ASTM D2240.
- B. Isolation Joints: Fillers shall consist of 1/8-inch width strips of neoprene, synthetic rubber, or approved substitute, extending the full depth of the slab. Sealant shall be two-part elastomeric type, polyurethane base.
- C. Expansion- and Isolation-Joint-Filler Strips: ASTM D 1751, asphalt-saturated cellulosic fiber or ASTM D 1752.

2.6 VAPOR BARRIER/RETARDER

- A. Provide cover over prepared soil, below or above aggregate subbase material at slabs-on-grade, where shown on the plans with a minimum thickness of 10 mils and when field conditions dictate. Use only materials which are resistant to decay.

2.7 PROPORTIONING

- B. Prepare design mixes for each type and strength of concrete by either laboratory trial batch or field experience methods as specified in ACI 301. If laboratory trial batch method is used, use an independent testing facility acceptable to Contracting Officer for preparing and reporting proposed mix designs. The testing facility shall not be the same as used for field quality control testing and inspection unless otherwise acceptable to Contracting Officer.
- C. Submit written reports to the testing laboratory of each proposed mix for each class of concrete. Do not begin concrete production until mixes have been reviewed and approved.
- D. Concrete types and strengths: Minimum 28 Day Compressive Strength shall be per design requirements but not less than:
 - 1. Paving base, columns, beams, walls, foundations, and footings: 3,500 psi.
 - 2. Slab-on-grade: 4,000 psi.
 - 3. Normal or Lightweight concrete on metal deck: 3,000 psi.
 - 4. Tilt-up: 4,000 psi.
 - 5. All concrete exposed to weather shall be air entrained (ASTM C260).
 - 6. All concrete shall be normal weight except as noted above.
- E. Durability: Conform to ACI 301.
 - 1. All concrete exposed to potentially destructive weathering, such as freezing and thawing, or to deicer chemicals is to be air-entrained, [] ± 1 percent.,
 - 2. Water-cement ratio: For concrete subject to freezing and thawing or deicer chemicals, the water-cement ratio shall not exceed 0.53 by weight including any water added.
- F. Slump: Conform to ACI 301 and to specific project mix requirements.
- G. Production of concrete: Conform to ACI 301:
 - 1. Cast-in-place concrete used in the work shall be produced at a single off-site batching plant or may be produced at an on-site batch plant.

2. All concrete shall be proportioned conforming to the approved mix designs and of the materials contained in those approved mixes.
3. Prior to adding a high-range water reducer (super plasticizer), slump shall not exceed the working limit.
4. Ready-mixed and on-site batched concrete shall be batched, mixed, and transported in accordance with ASTM C94.
 - a. The concrete producer shall furnish duplicate delivery tickets, one for the Contractor and one given to the Owner's Representative for each batch of concrete. The information provided on the delivery ticket shall include the quantity of materials batched including the amount of free water in the aggregate and any water added onsite. Show the date, time of day batched, and if ready-mixed the time of discharge from the truck. The quantity of water that can be added at the site without exceeding the maximum water-cementitious ratio specified shall be noted on the delivery ticket.
5. For concrete produced on site with a central batch plant, mixing shall be done in an approved batch mixer concrete shall be batched, mixed, and transported in accordance with ASTM C94.
6. Variations in consistency during the discharge of a single batch shall not exceed 1 inch of slump, except that a greater variation will be permitted if the slump of the concrete decreases and no water is added.
7. All other concrete: Conform to ACI 301
8. When improved workability, pumpability, lower water-cement ratio, or high ultimate and/or early strength is required, the HRWR admixture (super plasticizer) may be used.
9. Ensure air content for slabs with steel trowel finish is less than 3.0 percent.
10. No water shall be added to concrete except under the direct awareness of the project inspector.
11. Adjustments to concrete mixes: Mix design adjustments may be requested by Contractor for approval by the Engineer at no additional cost to Contracting Officer. Laboratory test data for revised mix design and strength results must be submitted and accepted before using in work.

2.8 FORMWORK

- A. Section 031000: Concrete Forming and Accessories

2.9 REINFORCING MATERIALS

- A. Section 032000: Concrete Reinforcement

PART 3 - EXECUTION

3.1 EXAMINATION

- A. Section 017300 - Execution: Verification of existing conditions before starting work.
- B. Verification of Conditions: Verify that field measurements, surfaces, substrates and conditions are as required, and ready to receive Work.
- C. Report in writing to Contracting Officer prevailing conditions that will adversely affect satisfactory execution of the Work of this Section. Do not proceed with Work until unsatisfactory conditions have been corrected.
- D. By beginning Work, Contractor accepts conditions and assumes responsibility for correcting unsuitable conditions encountered at no additional cost to the United States Postal Service.

3.2 INSTALLATION - GENERAL

- A. Install all cast-in-place concrete work in accordance with ACI 301 except as herein specified.
- B. All bearing materials shall be inspected by the Geotechnical Engineer prior to placing concrete. The Geotechnical Engineer specify site preparation requirements and provide recommendations to the Architect/Engineer prior to placing concrete.
- C. Immediately before placing concrete, spaces to be occupied by concrete shall be free from standing water, ice, mud, and debris.
- D. Concrete shall not be deposited under water or where water in motion may injure the surface finish of the concrete.
- E. Forms and the reinforcement shall be thoroughly cleaned of ice and other coatings. Remove surplus form releasing agent from the contact face of forms.
- F. Notify all trades concerned and the Owner's Representative sufficiently in advance of the scheduled time for concrete placement to permit installation of all required work by other trades.
- G. Before placing concrete, all required embedded items, including dovetail anchor slots, anchors, inserts, curb angles, metal frames, fixtures, sleeves, drains, stair nosings, accessory devices for Mechanical and Electrical installations shall be properly located, accurately positioned and built into the construction, and maintained securely in place.
- H. Build into construction all items furnished by the Owner and other trades. Provide all offsets, pockets, slabs, chases and recesses as job conditions require.
- I. Place and properly support reinforcing steel and anchor bolts.
- J. The alignment, orientation, spacing, and embedment length of mechanical load transfer devices in slab-on-grade and pavements shall conform to dimensions and tolerances shown on the drawings.

3.3 INSTALLATION - FORMWORK

- A. Section 031000 Concrete Forming and Accessories
- B. Construction and Contraction Joints: Conform to ACI 301 and recommendations of ACI 302.1R.

3.4 REINFORCEMENT

- A. Placement: Section 032000 Concrete Reinforcement

3.5 METHODS OF PLACEMENT AND PLACING CONCRETE

- A. Placement: Conform to ACI 301:
 - 1. Concrete shall be placed within 90 minutes after the water has been added to the cement and aggregates. Concrete shall be placed prior to initial concrete set.
 - 2. Placing of concrete will not be permitted during rainfall or when rain appears imminent. If rain should fall subsequent to placement, the concrete shall be completely protected until curing is complete.
 - 3. Cold-Weather Placement: Comply with provisions of ACI 306.1 "Standard Specifications for Cold-Weather Concreting" for placement at temperatures below 40 deg F (4 deg C).

033000 - 7

- a. Do not use calcium chloride, salt, or other materials containing antifreeze agents or chemical accelerators unless otherwise accepted in mix designs.
 - b. Concrete shall not be placed on frozen ground or placed when the ambient temperature is 40 deg F or less and dropping.
 - c. Protect concrete work from physical damage or reduced strength that could be caused by frost, freezing actions, or low temperatures using vented heaters and insulating blankets.
 - d. Concrete temperatures shall be maintained above 50 degrees F for the first 7 days of curing.
4. Hot-Weather Placement: When hot weather conditions exist that would impair quality and strength of concrete, place concrete complying with ACI 305R "Standard Specification for Hot-Weather Concreting" for placement at temperatures above 90 deg F (32 deg C).
- a. Reject any concrete that has a temperature at the point of placement above 90 deg F unless approved otherwise by the Engineer. When air temperatures are between 80 and 90 deg F the maximum mixing and delivery time is reduced to 75 minutes. When air temperatures exceed 90 deg F, the maximum mixing and delivery time is reduced to 60 minutes.
 - b. Use water-reducing retarding admixture when required by high temperatures, low humidity, or other adverse placing conditions, as acceptable to the Engineer.
- B. Depositing Concrete
1. Deposit concrete as near its final position as possible to avoid segregation due to rehandling or flowing.
 2. The number, type, position, and design of joints shall be approved by the Engineer prior to concrete placement.
 3. Place floor slabs-on-grade in alternating strips, waiting a minimum of 3 days before placing any slab adjacent to previously placed slab.
 4. The concreting shall be carried on at such a rate that the concrete is plastic at all times and flows readily into the spaces between reinforcing bars. No concrete that has partially hardened or been contaminated by foreign materials shall be deposited in the work
 5. When concreting is started, it shall be carried on as a continuous operation until the placing of the section is completed.
 6. Except as intercepted by joints, concrete shall be placed in continuous layers.
 7. Field records shall be kept of the time and date of the placing of each concrete pour. Locations where concrete test cylinders are made shall also be recorded. Records shall be kept on file at the job until its completion and shall be subject to the inspection of the Owner's Representative at all times.
- C. Joints
1. Joints shall be vertical in walls and horizontal in slabs [unless otherwise specified on the drawings].
 2. Dowel bars and tie bars shall be inspected
 3. Control joints for controlling concrete shrinkage shall be provided in floor slabs, walls, decks, conduits, and channels as shown on the plans or approved by the Engineer.
 4. Joint spacing and sawcut depth for slab-on-grade and concrete pavement shall conform to that shown on the pour sequencing plan and/or drawings.
 - a. Sawed control (contraction) joints for pavements and slab-on-grade shall be installed as soon as practical so as not to ravel the concrete but less than 12 hours.
 - b. Joint spacing shall not exceed 15 feet on center each way unless otherwise approved by the Engineer.
 5. Joints in slabs shall align with column lines and joints in adjoining walls unless otherwise approved by the Architect/Engineer or shown in the drawings. Joints shall also line up with architectural reveals and form lines. All corners shall be relieved by cutting joint to adjacent control joint.
 6. If there is a delay in casting but prior to concrete initial set, the concrete placed after the delay shall be thoroughly spaded and consolidated at the edge of that previously placed to avoid cold joints.
 7. Where placing concrete is interrupted long enough for the concrete to take its initial set, the working face shall be made a construction joint.
 - a. Preparation and disposition of unplanned cold joints in walls shall be approved by the Engineer.
 - b. For slab-on-grade, pavements, sidewalk, and curb and gutter, concrete shall be removed back to the nearest planned joint and a construction joint installed.

8. Unless otherwise noted on the drawings, where concrete is to be placed against existing concrete, except in the case of expansion joints, the joint face of the existing concrete shall be roughened.
9. Corner sections of walls shall not be placed until the adjoining wall sections have cured at least 14 days.

D. Consolidation

1. All concrete shall be thoroughly consolidated by internal mechanical vibrators during the placing operation and shall be thoroughly worked around the reinforcement and embedded fixtures and into corners of the forms.
2. Consolidation shall be carried on continuously with the placing of concrete.
3. Slabs shall be placed using vibrating screed.
4. The vibrator shall be kept in nearly a vertical position as practical. The use of vibrators to shift or drag concrete after deposition will not be permitted. Vibrators shall not be laid horizontally or laid over.
5. Concrete shall not be placed until the previous layer has been vibrated.
6. Unless directed otherwise by the Engineer, the top 2 feet of walls shall be re-vibrated approximately 1 hour after placement of concrete and while a running vibrator will still sink under its own weight into the concrete and liquefy it momentarily.

E. Protection of cast concrete: Conform to ACI 301.

F. Repair of surface defects: Conform to ACI 301.

3.6 FINISHING

A. Finishing of formed surfaces: ACI 301:

1. Tops of forms:
 - a. Strike concrete smooth at tops of forms.
 - b. Float to texture comparable to formed surfaces.
2. Formed surfaces:
 - a. Finished formed surfaces shall conform accurately to the shape, alignment, grades, and sections shown on the drawings or prescribed by the Engineer.
 - b. Surfaces shall be free from fins, bulges, ridges, honeycombing, or roughness of any kind and shall present a finished, smooth, continuous hard surface.
 - c. Rough form finish at unfinished areas unexposed to public view. Smooth form finish at surfaces exposed to public view.

B. Slabs: Minimum slab surface tolerance must satisfy ACI 301 and ACI 302.1R.

1. Slabs-on-grade:
 - a. For exposed slabs, install semi-rigid epoxy sealant in construction and contraction joints after slab has a minimum of 60 days or otherwise approved by the Engineer.
 - b. Allowable tolerance for slab on grade surfaces, measured in accordance with ACI 117 shall meet or exceed an overall value of FF35/FL25, with minimum local value of FF24/FL17.
2. Suspended Floor Slab:
 - a. Minimum surface tolerances: FF25 & FL20 overall and FF20 & FL15 local.
3. Concrete Finishes:
 - a. Floor Slabs: Steel trowel finish unless otherwise noted on the plans.
 - b. Exposed concrete slabs sealed or sealed and hardened using a liquid compound compatible with the curing method used.
 - c. Exterior Concrete Finishes: Unless otherwise noted on the drawings, floors, walkways, and roof finishes shall be sloped a minimum 0.125 inch per foot to drain water. A light steel trowel with broom finish unless otherwise noted on the plans. Apply exterior sealer to surfaces exposed to deicer chemicals that is compatible with the curing method used.
 - d. Exposed Ramps, Landings and Stair Treads: A light steel trowel with broom finish unless otherwise noted on the plans. Surfaces shall be sealed or sealed and hardened using a liquid compound compatible with the curing method used.

- e. A heavy broom finish shall be provided on disabled person ramps, utility ramps, and around exterior loading docks.

3.7 CURING, PROTECTION, LIQUID HARDNERS AND SEALERS

A. Temperature, Wind, and Humidity

1. When concrete slabs and other unformed concrete is placed in warm, dry, dusty, or windy conditions, concrete surfaces shall be protected from rapid drying by use of windbreaks, shading, fogging with properly designed nozzles, or a combination of these measures. Hot weather concreting procedures provided in ACI 305R shall be used when ambient conditions dictate.
2. Cold weather concreting procedures provided in ACI 306R shall be used when ambient conditions dictate.

B. Curing Compound

1. Apply curing compound to all interior and exterior flat slab and vertical surfaces. After curing period has elapsed, remove curing compound without damaging concrete surfaces by method recommended by curing compound manufacturer.
2. All curing methods shall be placed [within two hours] after final finishing. All exposed surfaces of concrete including floor slabs, whether or not they receive a finish flooring, shall be protected from premature drying for a minimum of seven days.
3. Apply the specified curing compound in accordance with manufacturer's written instructions.
4. When used on an unformed concrete surface, application of the first coat of curing compound shall commence immediately after finishing operations have been completed. When curing compound is used on a formed concrete surface, the surface shall first be moistened with a fine spray of water immediately after the forms have been removed.
 - a. Surfaces shall be sprayed uniformly with 2 coats of curing compound. As soon as the first coat has become dry, a second coat shall be applied in the same manner. The direction of application of the second coat shall be perpendicular to the first coat.

C. Hardner

1. Apply liquid densifier/sealer/hardener to all workroom, interior and exterior mail platform, and dock, BMEU, and similar floor surfaces.
2. Apply in accordance with manufacturer instructions.

D. Exterior Sealer

1. Apply to all exterior horizontal traffic and pedestrian surfaces that are exposed to salts, deicer chemicals, and moisture, including parking decks.
2. Apply in accordance with manufacturer's instructions.

E. Protection

1. Freshly placed concrete shall be protected against wash by rain.
2. Dust control shall be provided in the surrounding areas during placement.
3. During the first 2-day period of curing, no traffic on or loading of the floors will be permitted unless otherwise approved by the Engineer.
4. The contractor shall allow no traffic and take precautions to avoid damage to the membrane of the curing compound for a period of not less than 28 days. Damage shall be repaired immediately.
5. Self-supporting structures shall not be loaded in such a way to overstress the concrete.

- F. All floor slabs shall be cured using products and methods compatible with selected floor adhesives, toppings, and other finish materials.

3.8 PATCHING AND REPAIR

- A. All repairs of defective areas shall conform to ACI 301. On areas requiring treatment of defects and until such repairs have been completed, only water cure will be permitted

- B. At any time prior to final acceptance, concrete found to be defective, damaged, or not in accordance with the specifications shall be repaired or removed and replaced with acceptable concrete.
- C. Repair or replace concrete with excessive honeycombing due to improper placement.
 - 1. If approved, a bonding admixture, bonding compound, or epoxy adhesive may be used in accordance with the manufacturer's preparation and application recommendations. Comply with ACI 301 and ACI 503.2 for standard specifications for bonding plastic concrete to hardened concrete with a multiple component epoxy adhesive.
 - 2. The repair concrete shall be thoroughly consolidated in place and struck off so as to leave the patch slightly higher than the surrounding surface. The concrete shall be left undisturbed for at least 1 hour to permit initial shrinkage then finished.
 - 3. The patched area shall be kept damp for 7 days.
 - 4. The color of the patch material shall match the color of the surrounding concrete. Repairs shall be made promptly while the base concrete is less than 28 days old
- D. Areas showing excessive defects as determined by the Architect/Engineer shall be removed and replaced.
- E. High spots identified in the floor flatness and levelness survey may be removed with bump grinding. Areas to be ground shall not exceed more than 10 percent of any one slab nor more than 5 percent of the total slab-on-grade area.
- F. Random hairline cracks in up to 3% of the slab panels will be accepted. Cracks in these panels shall be routed and filled with semi-rigid joint filler. If more than 3% of panels contain cracks, the number of panels exceeding the 3% limit shall be demolished and replaced at the direction of the Contracting Officer, crack repairs will not be accepted. Any panels that contain cracks wider than 0.022" shall be demolished and replaced.
- G. Interior slab-on-grade hairline cracks allowed to be repaired that are subjected to powered industrial truck traffic shall be routed and sealed with a semi-rigid epoxy sealant. Exterior slabs may be routed and sealed with the flexible joint sealant to be installed in pavement joints.

3.9 GROUTING

- A. After steel columns have been installed and leveled, grout the space between the bottom of the plate and concrete, using cement grout completely filling the space and forming solid bearing for the column base plate.

3.10 EVALUATION AND ACCEPTANCE OF CONCRETE

- A. Comply with ACI 301, ACI 318-Chapter 5 and ACI 311 for compressive strength, slump, and frequency of testing.
- B. The frequency of testing indicated in the aforementioned codes and standards shall be increased if concrete fails to meet the acceptance criteria or if deemed by the Engineer to be too variable.

3.11 ACCEPTANCE OF STRUCTURE

- A. Comply with ACI 301 and modifications in this section.
- B. Completed concrete work, which meets all applicable requirements, will be accepted without qualification.
- C. Completed concrete work which fails to meet one or more requirements, but which has been repaired to bring it into compliance will be accepted without qualification.

- D. Completed concrete work which fails to meet one or more requirements, and which cannot be brought into compliance may be accepted or rejected by the Contracting officer. In this event, modifications may be required to assure that remaining work complies with the requirements.
- E. The costs of any additional tests or analysis, including additional architectural and engineering services, performed to prove the adequacy of the concrete work, shall be borne by the Contractor without extension of contract time.

3.12 MISCELLANEOUS CONCRETE

- A. Curbs: Provide monolithic finish to interior surface of curbs by stripping forms while concrete is still green and steel-troweling surfaces to a hard, dense finish with corners, intersections, and terminations slightly rounded.
- B. Equipment bases and foundations: Provide machine and equipment bases and foundations as shown on drawings. Set anchor bolts for machines and equipment with template at correct elevations, complying with certified diagrams or templates of manufacturer furnishing machines and equipment.

3.13 FIELD QUALITY CONTROL

- A. Section 014000 - Quality Requirements: Field testing and inspection.
- B. Requirements:
 - 1. Provide and maintain an adequate program of quality control for the materials, production methods, and workmanship to assure conformance of all work to the project contract documents.
 - 2. Testing and Evaluation:
 - a. Furnish and pay for the services of an independent Testing Laboratory satisfactory to the Contracting Officer. The testing laboratory shall have prime responsibility for review, verification inspection, and testing of the concrete producer's materials, operations, facilities, and quality control procedures and evaluating the results for conformance with these specifications.
 - b. In addition to the requirements and duties in ACI 301 the testing laboratory shall provide the following:
 - a. One or more additional test cylinders shall be taken during cold weather concrete placement and cured on the job site under conditions of concrete represented to determine safe form-stripping period.
 - b. Inspect concrete batching, mixing, and delivery operations periodically or as directed by the Contracting Officer.
 - c. Submit to the Contracting Officer and concrete producer, during construction, the results of concrete tests.
 - c. The Testing Laboratory shall assess and report floor flatness and levelness in accordance with the requirements of this specification.
 - d. Field and concrete plant inspections are to be made by a competent representative of the Testing Laboratory during all structural concreting operations including periodic audit and spot check of the Producer's and/or Contractor's quality control procedures to assure proper and adequate control. When it appears that any material furnished fails to fulfill specification requirements, the Testing Laboratory is to report such deficiency immediately to the Contracting Officer and appropriately record it in his report.

END OF SECTION

USPS MPF Specification Last Revised: 10/1/2022

033000 - 12

SECTION 055000
METAL FABRICATIONS

PART 1 – GENERAL

1.1. SUMMARY

- A. Miscellaneous steel that is not covered in Section 051200.
- B. Door frames for special doors.
- C. Stairs, landing sand associated guardrails and handrails.
- D. Ladders.
- E. Loose lintels and shelf angles.
- F. Pipe bollards.
- G. Metal joint covers.
- H. Interior pedestrian guardrails
- I. Pipe bollard plastic covers

1.2 SUBMITTALS

- A. Shop Drawings: Required
- B. Samples: Required
- C. Product Data: Required

1.3 QUALITY ASSURANCE

- A. Quality Standards: Comply with ASTM and AISC requirements.
- B. Regulatory Requirements:
 - 1. Design stair assembly to support live load of 100 pounds per square foot with deflection of stringer or landing framing not to exceed 1/240 of span.
 - 2. Design guardrail system for the following loads applied to the top rail:
 - a. Uniform load of 50 pounds per linear foot applied horizontally and concurrently with uniform load of 100 pounds per linear foot applied vertically downward.
 - b. Concentrated load of 250 pounds applied at any point and in any direction.
 - c. Concentrated and uniform loadings shall not be applied simultaneously.
 - 3. Design handrails for the following loads:
 - a. Uniform load of 50 pounds per linear foot applied in any direction.
 - b. Concentrated load of 250 pounds applied at any point and in any direction.
 - c. Concentrated and uniform load shall not be applied concurrently.
 - 4. Conform to applicable Building Code and OSHA requirements.

PART 2 – PRODUCTS

2.1 MATERIALS

- A. Structural Steel Members: Conform to ASTM A 36.
- B. Tubing, Pipe: Conform to ASTM A 53.
- C. Sheet: Conform to ASTM A 568.
- D. Welding: Conform to AWS D1.1 "Structural Welding Code."
- E. Bolts, Nuts and Washers: Conform to ASTM A 307.
- F. Handrail Fittings: Cast or Machined steel.
- G. Pipe Bollard: 6" dia., Schedule 40 pipe, concrete filled with end cap.
- H. Extruded Aluminum: ASTM B 221
- I. Interior Pedestrian Guardrail: W beam rail elements fabricated from corrugated sheet steel conforming to AASHTO M 180, Type 3, Class A with W6 x 9 post and base plate for bolted connection to slab.
- J. Anchors and Fasteners for Aluminum: Stainless Steel, ASTM A 304
- K. Pipe Bollard Plastic Covers: Exterior shell cover of low density polyethylene and interior steel sleeve. Covers are to be 1/4 inch nominal wall thickness with ultraviolet and anti-static additives and a dome top. Install over steel pipe posts as indicated on Drawings. Subject to compliance with project requirements, manufacturers offering Products which may be incorporated in the Work include the following:
 - 1. Ideal Shield, L.L.C., Detroit, MI (313) 842-7290, (800) 731-1722.
 - 2. Liberty Equipment Sales, Houston, TX (281) 987-8708, (888) 987-8708.

2.2 FABRICATION

- A. Stairs and Landings:
 - 1. Closed risers and concrete filled metal pan treads construction.
 - 2. Form treads, landings, and riser of sheet steel stock.
 - 3. Form stringers with rolled steel channels or rectangular hollow sections.
- B. Handrails:
 - 1. Form posts and railings from steel pipe sections.
- C. Shop/Factory Finishing:
 - 1. Interior components: Prime painted.
 - 2. Exterior components: Galvanized.

2.3 FIELD QUALITY CONTROL

- A. Field Test: If required by Local codes.
- B. Field Inspection: If required by Local codes.

2.4 SCHEDULES

- A. Door Frames for Exterior Overhead Door Openings: Channel sections; galvanized finish.
- B. Frames for Interior Impact, Overhead Coiling and Rapid Roll-up Doors: Channel sections; primed finish.
- C. Dock leveler edge angles: Galvanized finish.

- D. Dock edge channels: Galvanized finish.
- E. Pipe bollards: Primed finish for interior and galvanized finish for exterior.
- F. Interior Pedestrian Guardrails: primed finish with safety yellow top coat.
- G. Interior ladders: Primed finish.
- H. Exterior ladders: Galvanized finish.
- I. Stair nosings at concrete stairs: Provide cast non-corrosive metal safety nosing (minimum 3" x 3/8") with cross-hatched abrasive surface and integrally cast anchors at each exposed concrete stair tread.
- J. Expansion joint covers: Extruded aluminum clear anodized finish.
- K. Loose steel lintels in masonry openings: Galvanized finish, exterior; primed finish, interior.
- L. Shelf angles: Galvanized finish.

PART 3 – EXECUTION

- 3.1 Install all products in accordance with manufacturer's guidelines and printed instructions.

END OF SECTION

USPS MPF Specification Last Revised: 10/1/2022

SECTION 078400

FIRESTOPPING

PART 1 - GENERAL

1.1 SUMMARY

- A. Section Includes:
 - 1. Firestopping in fire-rated wall assemblies.
- B. Related Documents: The Contract Documents, as defined in Section 011000 - Summary of Work, apply to the Work of this Section. Additional requirements and information necessary to complete the Work of this Section may be found in other documents.

1.2 REFERENCES

- A. American Society for Testing and Materials (ASTM):
 - 1. ASTM E 119 - Test Methods for Fire Tests of Building Construction and Materials.
 - 2. ASTM E 814 - Test Methods for Fire Tests of Through Penetration Fire Stops.
- B. Underwriters' Laboratories, Inc. (UL):
 - 1. UL 1479 - Fire Tests of Through-Penetration Firestops.

1.3 DEFINITIONS

- A. Firestopping: Sealing material or assembly placed in spaces between building materials to stop movement of smoke, heat, gasses, or fire through wall openings.

1.4 SYSTEM DESCRIPTION

- A. Firestopping Materials: ASTM E 119, ASTM E 814, UL 1479 to achieve a fire rating as indicated on Drawings.

1.5 SUBMITTALS

- A. Section 013300 - Submittal Procedures: Procedures of submittals.
 - 1. Product Data: Product characteristics, performance, and limitation criteria.
 - 2. Assurance/Control Submittals:
 - a. Certificates: Manufacturer's certificate that Products meet or exceed specified requirements.
 - b. Qualification Documentation: Firestopping installer documentation of experience indicating compliance with specified qualification requirements.

1.6 QUALITY ASSURANCE

- A. Installer Qualifications: Company specializing in performing work of this Section with minimum 5 years documented experience.

1.7 DELIVERY, STORAGE, AND HANDLING

- A. Deliver Products in manufacturer's original unopened containers or packages with labels intact, identifying product and manufacturer, date of manufacture, lot number, shelf life, curing time, and mixing instructions, where applicable.
- B. Store and handle materials to prevent deterioration or damage due to moisture, temperature changes, contaminants, or other causes.

1.8 PROJECT CONDITIONS OR SITE CONDITIONS

- A. Environmental Requirements:
 - 1. Do not install materials when temperature of substrate material and ambient air is below 60 degrees F.
 - 2. Maintain minimum temperature before, during, and for 3 days after installation of materials.
 - 3. Keep away from heat, open flame, sparks, or other sources of ignition until curing is complete. Use only with adequate ventilation.

PART 2 - PRODUCTS

2.1 MANUFACTURERS

- A. Subject to compliance with project requirements, manufacturer's offering firestopping materials which may be incorporated in the work include the following:
 - 1. Nelson Firestop Products, Tulsa, OK (800) 331-7325.
 - 2. Hilti Firestop Systems, Tulsa, OK (800) 879-8000.
 - 3. The Rectorseal Corporation, Houston, TX (800) 231-3345.
 - 4. Specified Technologies, Incorporated (STI), Somerville, NJ (800) 992-1180.
 - 5. 3M Fire Protection Products, St. Paul, MN (800) 328-1687.
 - 6. Tremco Firestop System, Beechwood, OH (800) 321-7906.
 - 7. Specified Technologies, Inc., Somerville, NJ (800) 992-1180.
- B. Other products such as USG Firestop System by U.S. Gypsum Co. are acceptable if complying with requirements.
- C. Section 016000 - Product Requirements: Product options and substitutions. Substitutions: Permitted.

2.2 MATERIALS

- A. Intumescent Latex Sealant: Single-component, intumescent, latex formulation.
 - 1. LBS, by Nelson Firestop Products.
 - 2. Metacaulk 950 or 1000, by RectorSeal.
 - 3. SpecSeal SSS100, by STI.
 - 4. CP 25WB+, by 3M.
 - 5. TREMstop WBM, by Tremco.
- B. Intumescent Solvent-Release-Curing Sealant: Single component, intumescent, synthetic-polymer based, non-sag grade.
 - 1. CP 25N/S, by 3M.
 - 2. TREMstop WBM, by Tremco.
- C. Intumescent Wrap/Strip: Single-component, elastomeric sheet with aluminum foil on one face.
 - 1. WRS, by Nelson Firestop Products.

Tacoma, WA

2. Metacaulk Wrap Strip, by RectorSeal.
 3. SpecSeal SSWRED Wrapstrip, by STI.
 4. FS-195+ Wrap/Strip, by 3M.
 5. TREMstop WS, by Tremco.
- D. Intumescent Putty: Single-component, non-hardening, dielectric, intumescent putty.
1. FSP, by Nelson Firestop Products.
 2. Metacaulk Fire Rated Putty, by RectorSeal.
 3. SpecSeal Putty, by STI.
 4. Moldable Putty+, by 3M.
- E. Silicone Sealant: Single-component, moisture-curing, silicone-based elastomeric, non-sag grade.
1. CLK N/S, by Nelson Firestop Products.
 2. FS 601, by Hilti.
 3. Metacaulk 835+, by RectorSeal.
 4. SpecSeal PEN 300, by STI.
 5. 2000+ Silicone, by 3M.
 6. FYRE SIL, by Tremco.
- F. Silicone Foam: Two-component, silicone-based liquid elastomer that, when mixed, expands and cures in place to produce a flexible, nonshrinking foam.
1. FS Fireblocks, by Hilti.
 2. SpecSeal PEN 200, by STI.
 3. 2001 Silicone RTV Foam, by 3M.
- G. Intumescent Collar: Factory-fabricated, intumescent collar.
1. PCS, by Nelson Firestop Products.
 2. CP 642, by Hilti.
 3. Metacaulk Pipe Collar, by RectorSeal.
 4. SpecSeal SSC Collars, by STI.
 5. Plastic Pipe Device, by 3M.
 6. TREMstop D, by Tremco.
- H. Intumescent Composite Sheet or Pillows and Mortar: Intumescent sheet used to firestop large openings.
1. CPS, by Nelson Firestop Products.
 2. SpecSeal SSB Pillows and SpecSeal SSM Firestop Compound, by STI.
 3. CS-195+ Composite Sheet, by 3M.
 4. TREMstop PS, by Tremco.
- I. Fire Rated Cable Pathway Device for low voltage and optical fiber cabling.
1. EZ-Path Firestop System by Specified Technologies, Inc.
- J. Packing Material: Manufacturer's standard mastic, putty, ceramic fiber blanket, or mineral wool to be used as fill or backing material for firestopping.
1. FSB or Mineral Wool, by Nelson Firestop Products.
 2. Mineral Wool, by Hilti.
 3. Fire Safing or Backer Rod, by RectorSeal.
 4. Mineral Wool Safing, by STI.
 5. FireMaster Mastic, FireMaster Putty, or FireMaster Bulk, by 3M.
 6. Cerablanket, by Tremco.

PART 3 - EXECUTION

3.1 EXAMINATION

- A. Section 017300 - Execution: Verification of existing conditions before starting work.

078400 - 3

- B. Verification of Conditions: Verify that field measurements, surfaces, and conditions are as required, and ready to receive Work.
- C. Report in writing to Contracting Officer prevailing conditions that will adversely affect satisfactory execution of the Work of this Section. Do not proceed with Work until unsatisfactory conditions have been corrected.
- D. By beginning Work, Contractor accepts conditions and assumes responsibility for correcting unsuitable conditions encountered at no additional cost to United States Postal Service.

3.2 PREPARATION

- A. Clean substrate surfaces of dirt, dust, grease, oil, loose material, or other matter which may affect bond of firestopping material.
- B. Remove incompatible materials which may affect bond.
- C. Place hangers or damming materials in penetration to hold firestopping materials where required.

3.3 INSTALLATION

- A. Follow manufacturer charts for appropriate material to achieve required fire rating in various locations.
- B. Install firestopping at penetrations of fire rated wall materials by sleeves, piping, ductwork, conduit, and other items in accordance with manufacturer's published instructions.

3.4 CLEANING AND PROTECTION

- A. Clean excessive fill materials and sealants adjacent to openings and joints as work progresses by methods and with cleaning materials approved by manufacturer's of firestopping Products and of products in which opening and joints occur.
- B. Protect firestopping during and after curing period from contact with contaminating substances or from damage resulting from construction operations.
- C. If damage occurs, cut out and remove damaged or deteriorated firestopping and install new materials.

3.5 FIELD QUALITY CONTROL

- A. Section 014000 - Quality Requirements: Inspection procedures.
- B. Contracting Officer will inspect each firestopping installation. Do not cover firestopping installations that will be concealed by other construction until Contracting Officer inspection.

3.6 SCHEDULES

- A. Provide firestopping complying with UL assemblies specified below.

Penetration	Assembly	Nelson	Hilti	RectorSeal	STI	3M	Tremco
-------------	----------	--------	-------	------------	-----	----	--------

Metal Pipe	CMU Wall 8" Thick or Less	CAJ1224 or CAJ1203	CAJ1150 or CAJ1158	CAJ1114 or CAJ1115	CAJ1079 or CAJ1217	CAJ1001 or CAJ1009	CAJ1179 or CAJ1187
	Gypsum Board Partition	WL1083 or WL1030	WL1052 or WL1054	WL1026 or WL1034	WL1049 or WL1079	WL1003 or WL1009	WL1020 or WL1051
Non-Metallic Pipe	CMU Wall 8" Thick or Less	CAJ2086	CAJ2095 or CAJ2109	CAJ2021 or WJ2025	CAJ2064 or CAJ2045	CAJ2005	CAJ2082 or FA2024
	Gypsum Board Partition	WL2071	WL2078	WL2015 or WL2104	WL2093 or WL2029	WL2002 or WL2005	WL2083 or WL2082
Cable Tray	CMU Wall 8" Thick or Less	CAJ8049 or CAJ4033	CAJ4017	CAJ8043	CAJ4020 or CAJ4029	CAJ4003 or CBJ4020	CAJ4007 or WJA4005
	Gypsum Board Partition	WL4003	WL4006	N/A	WL4005 or WL4008	WL4004	WL3043 or WL3044
Insulated Metal Pipe	CMU Wall 8" thick or Less	CAJ5008 or CAJ5059	CAJ5045	WJ5016 or CAJ5070	CAJ5021 or CAJ5029	CAJ5001 or CAJ5002	CAJ5052 or CBT5005
	Gypsum Board Partition	WL5036	WL5022 or WL5029	WL5057	WL5014 or WL5051	WL5001	WL5034
Construction Gaps	CMU Wall to Metal Deck	N/A	HW-D-0008	TRC/PV120-14	U900Z020	U900Z028	U900Z013 or U900Z014
	Gypsum Board Partition to Metal Deck	N/A	HW-D-0003 or HW-D-0004	HWD0014 or TRC/PV120-14	HWD1001	U400V	WHPV60.01 or U900Z014

END OF SECTION

USPS MPF Specification Last Revised: 10/1/2022

SECTION 079200

JOINT SEALANTS

PART 1 - GENERAL

1.1 SUMMARY

- A. Sealing of exterior building joints.
- B. Sealing of interior partition joints.
- C. Sealing of ceramic tile joints.
- D. Sealing of joints in exterior paving.

1.2 SUBMITTALS

- A. Product Data: Required
- B. Samples: Required

1.3 QUALITY ASSURANCE

- A. Quality Standards:
 - 1. SWRI (Sealant, Waterproofing and Restoration Institute) requirements for materials and installation.

PART 2 – PRODUCTS

2.1 MANUFACTURERS

- A. Exterior building joints: Polyurethane Sealant - single component, chemical curing, non-sagging type, 25 percent elongation capability, manufactured by Pecora, Sika, Tremco or Sonneborn.
- B. Interior partition joints: Silicone Sealant - single component, 50 percent elongation capability, manufactured by GE or Dow.
- C. Ceramic tile joints: Silicone Sealant - single component, solvent curing, fungus resistant, 25 percent elongation capability, manufactured by GE or Dow.
- D. Exterior horizontal traffic joints: Polyurethane Sealant - self-leveling, manufactured by Pecora, Sika, Tremco or Sonneborn.

2.2 ACCESSORIES/MIXES

- A. Joint Backing: Round open cell polyethylene urethane foam or butyl rod.

PART 3 – EXECUTION

- 3.1 Install all products in accordance with manufacturer's guidelines and printed instructions.

END OF SECTION

USPS MPF Specification Last Revised: 10/1/2022

079200 - 1

SECTION 083323

OVERHEAD COILING DOORS

PART 1 – GENERAL

1.1 SUMMARY

- A. Overhead coiling doors.

1.2 SUBMITTALS

- A. Shop Drawings: Required.
- B. Product Data: Required.
- C. Samples: Required
- D. Certificates of Quality Assurance: Required

1.3 QUALITY ASSURANCE

- A. Compliance with local governing codes.
- B. Compliance with ASCE-7 for wind loading requirements.

PART 2 – PRODUCTS

2.1 OVERHEAD COILING DOORS

- A. Approved manufacturers:
 - 1. Overhead Door
 - 2. Cornell
 - 3. Cookson
 - 4. Atlas
- B. Features:
 - 1. Curtain: Constructed of interlocking flat slat of a minimum 18 gauge thick front steel sheet and a min. 24 gauge rear steel sheet, approximately 3 inches high.
 - 2. Guides: Metal side guides, finish to match curtain.
 - 3. Hood: minimum 24-gauge steel sheet, finish to match curtain.
 - 4. Reversing Safety Edge.
 - 5. Counter Balance Assembly: Heat treated helical torsion springs secured within Steel-pipe barrel with a maximum deflection not to exceed .03 inches per foot of width.
 - 6. Operating Mechanism: Motor operated min. 1/2 HP, single phase, 120V. Provide disconnect to permit manual chain hoist operation in the event of power failure or motor burn-out. Provide electrical interlock to prevent motor burn-out in case lock remains engaged.
 - 7. Automatic Operation: Wall-mounted single key activated switch or induction loop.
 - 8. Locking: Security lockout capability.
 - 9. Insulation: Manufacturers standard rigid cellular polystyrene or polyurethane foam type insulation, foamed-in-place to completely fill cores of door.
 - 10. Finish: ~~Shop primed, and field painted.~~ Shop powder coat.

083323 - 1

PART 3 - EXECUTION

3.1. INSTALLATION

- A. Install all components in accordance with manufacturer's instructions.
- B. Upon completion of installation, provide field inspection and testing.

END OF SECTION

USPS MPF Specification Last Revised: 10/1/2022

SECTION 096723
RESINOUS FLOORING

PART 1 - GENERAL

1.1 RELATED DOCUMENT

- A. Drawings and general provisions of the Contract, including General and Supplementary Conditions and Division 01 Specification Sections, apply to this Section.

1.2 SUMMARY

- A. Section Includes: Slip-resistant epoxy coating for use on floors.
 - 1. Application Method: Metal, power or hand troweled.

1.3 RELATED SECTIONS

- A. Section 016000 - Product Requirements: Product options and substitutions.

1.4 REFERENCES

- A. ASTM C579 Standard Test Methods for Compressive Strength of Chemical-Resistant Mortars, Grouts, Monolithic Surfacing, and Polymer Concretes
- B. ASTM C580 Standard Test Method for Flexural Strength and Modulus of Elasticity of Chemical-Resistant Mortars, Grouts, Monolithic Surfacing, and Polymer Concretes
- C. ASTM D2240 Standard Test Method for Rubber Property—Durometer Hardness
- D. ASTM D2369 Standard Test Method for Volatile Content of Coatings
- E. ASTM D4060 Test Method for Abrasion Resistance of Organic Coatings
- F. ASTM E648 Standard Test Method for Critical Radiant Flux of Floor-Covering Systems Using a Radiant Heat Energy Source

1.5 SUBMITTALS

- A. Product Data: Indicate product components, compliance with physical characteristics, application method, required substrate moisture content, required storage conditions, and permitted disposal method for unused product.
- B. Product Safety Data Sheets.
- C. Applicator Qualifications: Evidence of certification by manufacturer and years of experience.
- D. Samples: Product applied to each type of substrate, 12 by 12-inch square. applied to a rigid backing.
- E. Product Schedule: Use resinous flooring designations indicated in Part 2 and room designations indicated on Drawings in product schedule.

- F. Maintenance Data: For resinous flooring to include in maintenance manuals.

1.6 QUALITY ASSURANCE

- A. No request for substitution shall be considered that would change the generic type of floor system specified (i.e. epoxy mortar based system). Equivalent materials of other manufactures may be substituted only on approval of Architect or Engineer. Request for substitution will only be considered only if submitted 10 days prior to bid date. Request will be subject to specification requirements described in this section.
- B. Installer Qualifications: Engage an experienced installer (applicator) who is experienced in applying resinous flooring systems similar in material, design, and extent to those indicated for this Project, whose work has resulted in applications with a record of successful in-service performance, and who is acceptable to resinous flooring manufacturer with minimum 5 years of experience installing manufacturer's product.
 - 1. Engage an installer who is certified in writing by resinous flooring manufacturer as qualified to apply resinous flooring systems indicated.
 - 2. Contractor shall have completed at least 10 projects of similar size and complexity.
- C. Source Limitations: Obtain primary resinous flooring materials, including primers, resins, hardening agents, grouting coats, and topcoats, through one source from a single manufacturer, with not less than ten years of successful experience in manufacturing and installing principal materials described in this section. Provide secondary materials, including patching and fill material, joint sealant, and repair materials, of type and from source recommended by manufacturer of primary materials.
- D. Manufacturer Field Technical Service Representatives: Resinous flooring manufacture shall retain the services of Field Technical Service Representatives who are trained specifically on installing the system to be used on the project.
 - 1. Field Technical Services Representatives shall be employed by the system manufacture to assist in the quality assurance and quality control process of the installation and shall be available to perform field problem solving issues with the installer.
- E. Mockups: Apply mockups to verify selections made under sample submittals and to demonstrate aesthetic effects and set quality standards for materials and execution.
 - 1. Apply full-thickness mockups on 48-inch- (1200-mm-) square floor area selected by Architect.

1.7 DELIVERY, STORAGE AND HANDLING

- A. Deliver materials in original packages and containers, with seals unbroken, bearing manufacturer's labels indicating brand name and directions for storage and mixing with other components.
- B. Store materials to prevent deterioration from moisture, heat, cold, direct sunlight, or other detrimental effects. Store material per product data sheet.
- C. All materials used shall be factory pre-weighed and pre-packaged in single, easy to manage batches to eliminate on site mixing errors. No on site weighing or volumetric measurements allowed.

1.8 SITE CONDITIONS

- A. Environmental Limitations: Comply with resinous flooring manufacturer's written instructions for substrate temperature, ambient temperature, moisture, ventilation, and other conditions affecting resinous flooring application.

1. Maintain material and substrate temperature between 65 and 85 deg F (18 and 30 deg C) during resinous flooring application and for not less than 24 hours after application.
- B. Lighting: Provide permanent lighting or, if permanent lighting is not in place, simulate permanent lighting conditions during resinous flooring application.
- C. Close spaces to traffic during resinous flooring application and for not less than 24 hours after application, unless manufacturer recommends a longer period.
- D. Concrete substrate shall be properly cured. A vapor barrier must be present for concrete subfloors on or below grade. Otherwise, an osmotic pressure resistant grout must be installed prior to the resinous flooring.

1.9 WARRANTY

- A. Manufacturer shall furnish a single, written warranty covering both material and workmanship for a period of (1) full years from date of installation, or provide a joint and several warranty signed on a single document by material manufacturer and applicator jointly and severally warranting the materials and workmanship for a period of (1) full year from date of installation.

PART 2 - PRODUCTS

2.1 MANUFACTURERS

- A. Basis of Design: Stonclad GS with Stonkote GS4 topcoat, Stonhard Inc., Maple Shade, NJ (800) 257-7953.
 1. Color: Pewter
 2. Aggregate: Silica sand or glass bead texture, 90 mesh aggregate size.
- B. Characteristics:
 1. ASTM C579: .10,000 psi after 7 days.
 2. ASTM C580: 4,000 psi
 3. ASTM D2240: Shore D, 85 to 90
 4. ASTM D2369: 4 g/l.
 5. ASTM D4060: 0.1 gm.
 6. ASTM E648: Flammability Class 1.

2.2 RESINOUS FLOORING

- A. Available Products: Subject to compliance with requirements, products that may be incorporated into the Work include,
 1. Build of Broadcast or liquid rich type systems will not be accepted, and will result in a disqualification from bid.
- B. Acceptable Manufactures:
 1. Stonhard Basis of Design.
- C. Products: Subject to compliance with requirements:
 1. Stonhard, Inc.; Stonclad GS®. With top coat Stonkote GS4.
- D. System Characteristics:

1. Color and Pattern: Pewter.
 2. Wearing Surface: Texture to meet ANSI 137.1 DCOF >0.42 for interior spaces 90 grit silica added to topcoat.
 3. Integral Cove Base: None.
 4. Overall System Thickness: Nominal 1/4"
- E. System Components: Manufacturer's standard components that are compatible with each other and as follows:
1. Primer:
 - a. Material Basis: Stonhard Primer 150 for moisture mitigation.
 - b. Resin: Epoxy
 - c. Formulation Description: (2) two component, 100 percent solids.
 - d. Application Method: Squeegee and roller.
 - e. Number of Coats: (1) one.
 2. Mortar Base:
 - a. Material design basis: Stonhard Stonclad GS
 - b. Resin: Epoxy.
 - c. Formulation Description: (3) three component, 100 percent solids.
 - d. Application Method: Metal Trowel.
 - 1) Thickness of Coats: nominal 1/4 inch
 - 2) Number of Coats: One.
 - e. Aggregates: Pigmented Blended aggregate.
 3. Top Coat:
 - a. Material design basis: Stonkote GS4
 - b. Resin: Epoxy.
 - c. Formulation Description: (2) two component 100 percent solids.
 - d. Type: pigmented.
 - e. Finish: Textured
 - f. Color: Pewter
 - g. Number of Coats: one.
- F. System Physical Properties: Provide resinous flooring system with the following minimum physical property requirements when tested according to test methods indicated:
1. Compressive Strength: 10,000 psi after 7 days per ASTM C 579.
 2. Tensile Strength: 1,750 psi per ASTM C 307.
 3. Flexural Strength: 4,000 psi per ASTM C 580.
 4. Water Absorption: < 1% per ASTM C 413.
 5. Impact Resistance: > 160 in. lbs. per ASTM D 2794.
 6. Flammability: Class 1 per ASTM E-648.
 7. Hardness: .85 to .90, Shore D per ASTM D 2240.
 8. Flexural Modulus of Elasticity: 2.0×10^6 psi per ASTM C-580
 9. Thermal Coefficient of Linear Expansion: 1.4×10^{-5} in./in.°F per ASTM C-531

2.3 ACCESSORY MATERIALS

- A. Patching, Leveling and Fill Material: Resinous product of or approved by resinous flooring manufacturer and recommended by manufacturer for application indicated.
- B. Joint Sealant: Type recommended or produced by resinous flooring manufacturer for type of service and joint condition indicated. Allowances should be included for Stonflex MP7 joint fill material.

PART 3 - EXECUTION

3.1 PREPARATION

- A. General: Prepare and clean substrates according to resinous flooring manufacturer's written instructions for substrate indicated. Provide clean, and dry substrate for resinous flooring application.
- B. Concrete Substrates: Provide sound concrete surfaces free of laitance, glaze, efflorescence, curing compounds, form-release agents, dust, dirt, grease, oil, and other contaminants incompatible with resinous flooring.
 - 1. Mechanically prepare substrates as follows:
 - a. Shot-blast surfaces with an apparatus that abrades the concrete surface, contains the dispensed shot within the apparatus, and recirculates the shot by vacuum pickup or Diamond grind with a dust free system.
 - 2. Repair damaged and deteriorated concrete according to resinous flooring manufacturer's written recommendations.
 - 3. Verify that concrete substrates meet the following requirements.
 - a. Perform in situ probe test, ASTM F 2170. Proceed with application only after substrates do not exceed a maximum potential equilibrium relative humidity of 85 percent.
 - b. Perform anhydrous calcium chloride test, ASTM F 1869. Proceed with application only after substrates have maximum moisture-vapor-emission rate of 6 lb of water/1000 sq. ft. of slab in 24 hours.
- C. Use patching and fill material to fill holes and depressions in substrates according to manufacturer's written instructions.
- D. Treat control joints and other nonmoving substrate cracks to prevent cracks from reflecting through resinous flooring according to manufacturer's written recommendations. Allowances should be included for Stonflex MP7 joint fill material, and CT5 concrete crack treatment.

3.2 APPLICATION

- A. General: Apply components of resinous flooring system according to manufacturer's written instructions to produce a uniform, monolithic wearing surface of thickness indicated.
 - 1. Coordinate application of components to provide optimum adhesion of resinous flooring system to substrate, and optimum intercoat adhesion.
 - 2. Cure resinous flooring components according to manufacturer's written instructions. Prevent contamination during application and curing processes.
 - 3. At substrate expansion and isolation joints, provide joint in resinous flooring to comply with resinous flooring manufacturer's written recommendations.
 - a. Apply joint sealant to comply with manufacturer's written recommendations.
- B. Provide ventilation during application as required by manufacturer.
- C. Apply each component in compliance with manufacturer's directions to produce a uniform monolithic coating, uninterrupted except at divider strips or at joints indicated or required.
- D. Primer: Mix and apply material according to manufacturer's procedures.

- E. Epoxy Base Coat: Mix and apply material according to manufacturer's procedures.
- F. Apply metal trowel single mortar coat in thickness indicated for flooring system. Hand or power trowel and grout to fill voids. When cured, sand to remove trowel marks and roughness.
- G. Top Coat: Mix and apply material according to manufacturer's procedures.
- H. At substrate expansion and isolation joints, provide joint in resinous flooring to comply with resinous flooring manufacturer's written recommendations. Apply joint sealant to comply with manufacturer's written recommendations.

3.3 TERMINATIONS

- A. Chase edges to "lock" the flooring system into the concrete substrate along lines of termination.
- B. Penetration Treatment: Lap and seal resinous system onto the perimeter of the penetrating item by bridging over compatible elastomer at the interface to compensate for possible movement.
- C. Trenches: Continue flooring system into trenches to maintain monolithic protection. Treat cold joints to assure bridging of potential cracks.
- D. Treat floor drains by chasing the flooring system to lock in place at point of termination.

3.4 JOINTS AND CRACKS

- A. Treat control joints to bridge potential cracks and to maintain monolithic protection.
- B. Treat cold joints and construction joints and to maintain monolithic protection on horizontal and vertical surfaces as well as horizontal and vertical interfaces.
- C. Vertical and horizontal contraction and expansion joints are treated by installing backer rod and compatible sealant after coating installation is completed. Provide sealant type recommended by manufacturer for traffic conditions and chemical exposures to be encountered.

3.5 FIELD QUALITY CONTROL

- A. Prevent material from pooling or puddling.
- B. Material Sampling: Owner may at any time and any numbers of times during resinous flooring application require material samples for testing for compliance with requirements.
 - 1. Owner will engage an independent testing agency to take samples of materials being used. Material samples will be taken, identified, sealed, and certified in presence of Contractor.
 - 2. Testing agency will test samples for compliance with requirements, using applicable referenced testing procedures or, if not referenced, using testing procedures listed in manufacturer's product data.
 - 3. If test results show applied materials do not comply with specified requirements, pay for testing, remove noncomplying materials, prepare surfaces coated with unacceptable materials, and reapply flooring materials to comply with requirements.

3.6 PROTECTION AND CLEANING

- A. Cure resinous flooring materials in compliance with manufacturer's directions, taking care to prevent contamination during stages of application and prior to completion of curing process. Close area of application for a minimum of 24 hours.
- B. Close area of application for a minimum of 24 hours.
- C. Prevent contamination during stages of application and prior to completion of curing process.
- D. Protect resinous flooring materials from damage and wear during construction operation. Where temporary covering is required for this purpose, comply with manufacturer's recommendations for protective materials and method of application. General Contractor is responsible for protection.
- E. Cleaning: Remove temporary covering and clean resinous flooring just prior to final inspection. Use cleaning materials and procedures recommended by resinous flooring manufacturer. General contractor responsible for cleaning prior to inspection.
- F. Dispose of unused materials in accordance with manufacturer's directions and local regulations.

END OF SECTION

USPS MPF Specification Last Revised: 10/1/2022

SECTION 099100

PAINTING

PART 1 - GENERAL

1.1 SUMMARY

- A. Section Includes:
 - 1. Surface preparation and field application of paints and finishes for interior and exterior surfaces.
 - 2. Schedule of Items to be painted.
 - 3. Exterior painting and finishing schedule.
 - 4. Interior painting and finishing schedule.

- B. Related Documents: The Contract Documents, as defined in Section 011000 - Summary of Work, apply to the Work of this Section. Additional requirements and information necessary to complete the Work of this Section may be found in other Documents.

- C. Related Sections:
 - 1. Section 055000 - Metal fabrications
 - 2. Section 055213 - Pipe and Tube Railings
 - 3. Section 081100 - Metal Doors and Frames: Shop priming.

1.2 REFERENCES

- A. American Society for Testing and Materials (ASTM):
 - 1. ASTM E 84 - Test Method for Surface Burning Characteristics of Building Materials.

1.3 SUBMITTALS

- A. Section 013300 - Submittals: Procedures for submittals.
 - 1. Product Data: Submit product data for each type of paint specified.
 - a. Technical data sheets indicating manufacturer's catalog number, paint type description, and VOC content.
 - b. Painting Schedule listing surfaces to be painted with cross reference to the specific painting and finishing system and application. Identify each paint material by manufacturer's catalog number and general classification.
 - 2. Samples: Submit color brush-out sample for each paint color and sheen specified.
 - a. Three samples on 8 1/2-inch x 11-inch card stock for color and sheen verification.
 - b. Identify each sample by paint manufacturer, paint type, color, and sheen.
 - 3. Assurance/Control Submittals:
 - a. Test Reports: Submit manufacturer's Safety Data Sheets (SDS) for each paint type proposed.

1.4 QUALITY ASSURANCE

- A. Applicator Qualifications: Company specializing in performing Work of this Section with minimum five years documented experience.

- B. Regulatory Requirements:
 - 1. Surface Burning Characteristics in Accordance with ASTM E-84 for Class I or A finish:

099100 - 1

Tacoma, WA

- a. Flame Spread (Non-Combustible Surfaces): Less than 25.
- b. Smoke Density (Non-Combustible Surfaces): Less than 450.
2. Provide paint and coating materials that conform to Federal, State, and Local restrictions for Volatile Organic Compounds (VOC) content.

1.5 DELIVERY, STORAGE AND HANDLING

- A. Section 016000 - Product Requirements: Transport, handle, store, and protect products.
- B. Deliver paint materials in sealed original labeled containers, bearing manufacturer's name, type of paint, brand name, lot number, brand code, coverage, surface preparation, drying time, cleanup requirements, color designation, and instructions for mixing and/or reducing.
- C. Store paint materials at minimum ambient temperature of 45 degrees F and a maximum of 90 degrees F, in ventilated area, and as required by manufacturer's published instructions.
- D. Prevent fire hazards and spontaneous combustion.

1.6 PROJECT CONDITIONS OR SITE CONDITIONS

- A. Environmental Requirements:
 1. Apply paint finishes only when moisture content of surfaces is within manufacturer's acceptable ranges for type of finish being applied.
 2. Surface temperatures or surrounding air temperature to be above 40 degrees F before applying alkyd finishes; above 45 degrees F for interior latex, and 50 degrees F for exterior latex work. Minimum for varnish and transparent finishes is 65 degrees F.
 3. Provide continuous ventilation and heating facilities to maintain temperatures above 45 degrees F for 24 hours prior to, during and 48 hours after application of finishes.
 4. Do not apply paint in areas where dust is being generated.
 5. Provide lighting level in areas being painted of 80-foot candles measured mid-height at substrate surface.

1.7 MAINTENANCE

- A. Section 017704 - Closeout Procedures and Training: Procedures for closeout submittals.
- B. Extra Materials:
 1. Provide one gallon of each color, type and sheen to USPS Project Manager.
 2. Label each container with color, type, texture, room locations, in addition to the manufacturer's label.

PART 2 - PRODUCTS

2.1 MANUFACTURERS

- A. Subject to compliance with project requirements, manufacturers offering specified items which may be incorporated in the work include the following:
 1. Benjamin Moore and Company, Montvale, NJ (201) 573-9600.
 2. PPG Paints, Pittsburgh, PA (800) 441-9695.
 3. Sherwin-Williams Company, Cleveland, OH (800) 321-8194.

099100 - 2

- B. Section 016000 - Product Requirements: Product options and substitutions. Substitutions: Permitted.

2.2 MATERIALS

A. Paints:

1. Manufacturer's "Best Grade" for each type specified.
2. Ready-mixed; pigments fully ground maintaining a soft paste consistency, capable of readily and uniformly dispersing to a complete homogeneous mixture.
3. Providing good flowing and brushing properties and be capable of drying or curing free of streaks or sags.
4. VOC limits (g/L) for exterior and interior paint applications:
 - a. Exterior- Steel-Shop Primed
 - 1) Top Coat – Non-Flat: 150
 - 2) Top Coat - Gloss: 250
 - b. Exterior- Steel - Galvanized
 - 1) Primer Coat: 200
 - 2) Top Coat - Non-Flat: 150
 - 3) Top Coat - Gloss: 250
 - c. Interior Wood – Transparent
 - 1) Stain: 250
 - 2) Varnish: 350
 - d. Interior Concrete, Concrete Block
 - 1) Block filler: 300
 - 2) Top Coat – Flat: 100
 - 3) Top Coat – Non-Flat: 150
 - 4) Top Coat – Gloss: 250
 - e. Interior Steel – Unprimed
 - 1) Rust Prime Coat: 400
 - 2) Top Coat – Non-Flat: 150
 - 3) Top Coat – Gloss: 250
 - f. Interior Steel – Primed
 - 1) Top Coat – Flat: 100
 - 2) Top Coat – Non-Flat: 150
 - 3) Top Coat – Gloss: 250
 - g. Interior Steel – Galvanized
 - 1) Top Coat – Non-Flat: 150
 - 2) Top Coat – Gloss: 250
 - h. Interior Plaster, Gypsum Board
 - 1) Undercoater: 200
 - 2) Top Coat - Flat: 100
 - 3) Top Coat – Non-Flat: 150
 - 4) Top Coat – Gloss: 250

- B. Primers and Undercoaters: Manufactured by same manufacturer as finish coat materials.

- C. Paint Accessory Materials: Linseed oil, shellac, turpentine and other materials not specifically indicated herein but required to achieve the finishes specified of high quality and approved manufacturer.

2.3 EXTERIOR PAINT SYSTEMS

A. Benjamin Moore:

1. Ferrous Metal: Semi-Gloss, Water Base, Alkyd Primer/Acrylic Latex.
 - a. Primer: V110 Acrylic Metal Primer, 3.5-4.6 mils wet, 1.4-1.9 mils dry.

- b. Each Finish Coat: V331 Acrylic DTM Enamel Semi-Gloss; 4.6-5.3 mils wet, 1.9-2.3 mils dry.
 2. Galvanized Metal: Semi-Gloss, Water Base, Alkyd Primer/Acrylic Latex.
 - a. Primer: V110 Acrylic Metal Primer; 3.5-4.6 mils wet, 1.4-1.9 mils dry.
 - b. Each Finish Coat: V331 Acrylic DTM Enamel Semi-Gloss; 4.6-5.3 mils wet, 1.9-2.3 mils dry.
- B. PPG Paints:
 1. Ferrous Metal: Semi-Gloss, Water Base, Alkyd Primer/Acrylic Latex.
 - a. Primer: 4020 PF Pitt-Tech Plus DTM Interior/Exterior Primer; MDF 3.0 mils.
 - b. Each Finish Coat: 90-1110 Series Acrylic Enamel Satin; MDF 3.0 mils.
 2. Galvanized Metal: Semi-Gloss, Water Base, Alkyd Primer/Acrylic Latex.
 - a. Primer: 4020 PF DTM Interior/Exterior Primer; MDF 3.0 mils.
 - b. Each Finish Coat: 90-1110 Acrylic Enamel Satin; MDF 3.0 mils.
 3. Concrete/Masonry Semi-Gloss Acrylic Latex MDF 1.5 mil.
 - a. Primer: 4-22 Perma Crete High Build 100% Acrylic Primer 7.0 mil.
 - b. Each Finish Coat: 4-22 Perma Crete High Build Acrylic Top Coat 1.5 mil.
- C. Sherwin-Williams:
 1. Ferrous Metal: Semi-Gloss, Low VOC, Alkyd Primer/Acrylic Latex.
 - a. Primer: Pro-Cryl Universal Water-Based Primer, B66-1310 Series, MDF 3.0 mils.
 - b. Each Finish Coat: DTM Acrylic B66 Series; MDF 3.0 mils.
 2. Galvanized Metal: Semi-Gloss, Water Base, Alkyd Primer/Acrylic Latex.
 - a. Primer: Pro-Cryl Universal Water Based Primer, B66-1310 Series, MDF 3.0 mils.
 - b. Each Finish Coat: DTM Acrylic B66 Series; MDF 3.0 mils.
 3. Concrete/Masonry Semi-Gloss Acrylic Latex MDF 1.5 mil.
 - a. Primer: Loxon Concrete & Masonry Primer MDF 3.0 mils.
 - b. Each Finish Coat: A-100 Exterior Acrylic, A8 Series MDF 3.0 mils.

2.4 INTERIOR PAINT SYSTEMS

- A. Benjamin Moore:
 1. Gypsum Board: Eggshell, Water Base, Acrylic Latex.
 - a. Primer: N534 Interior Latex Primer; 4.3 mils wet, 1.4 mils dry.
 - b. Each Finish Coat: Moorecraft Super-Hide Eggshell 286.
 2. Masonry: Eggshell, Water Base, Acrylic Latex.
 - a. Primer: 571 Ultra Spec Hi-Build Masonry Block Filler; 16-21 mils wet, 8.5-11.4 mils dry
 - b. Each Finish Coat: 485 Ultra Spec Scuff-X Interior Eggshell; 4.0-4.5 mils wet, 1.6-1.8 mils dry.
 3. Metal: Satin, Water Base, Acrylic Latex.
 - a. Each Finish Coat: WH25 Ultra Spec HP DTM Acrylic Low Lustre Enamel; 5.2 mils wet, 2.3 mils dry.
 4. Wood: Satin, Water Base, Acrylic Latex.
 - a. Primer: AQ-0400 Aqua Lock Plus 100% Acrylic Primer Sealer; 4.0-5.3 mils wet, 1.6-2.2 mils dry.
 - b. Each Finish Coat: 485 Ultra Spec Scuff-X Interior Eggshell; 4.0-4.5 mils wet, 1.6-1.8 mils dry.
 5. Concrete: Semi-Gloss, Water Base, Acrylic Latex.
 - a. Primer: 571 Ultra Spec Hi-Build Masonry Block Filler, 16-21 mils wet, 8.5-11.4 mils dry.
 - b. Each Finish Coat: 487 Ultra Spec Scuff-X Interior Semi-Gloss Finish, 4.3 mils wet, 1.6 mils dry.
 6. Ferrous Metal: Semi-Gloss, Water Base, Acrylic Latex.
 - a. Primer: V110 Acrylic Metal Primer; 3.5-4.6 mils wet, 1.4-1.9 mils dry.
 - b. Each Finish Coat: 487 Ultra Spec Scuff-X Interior Semi-Gloss Finish, 4.3 mils wet, 1.6 mils dry.
 7. Wood Cabinets and Wood Shelves: Semi-Gloss, Water Base, Acrylic Latex.

- a. Enamel Undercoater: AQ-0400 Aqua Lock Plus 100% Acrylic Primer Sealer; 4.0-5.3 mils wet, 1.6-2.2 mils dry.
 - b. Each Finish Coat: CC-66 Cabinet Coat Trim & Cabinet Enamel Semi-Gloss; 3.6-4.6 mils wet, 1.3-1.6 mils dry.
- B. PPG Paints:
- 1. Gypsum Board: Eggshell, Water Base, Acrylic Latex.
 - a. Primer: 6-2 Speedhide Latex Sealer; MDF 1.0 mils.
 - b. Each Finish Coat: 6-411 Speedhide Eggshell Latex; MDF 1.5 mils.
 - 2. Masonry: Eggshell, Water Base, Acrylic Latex.
 - a. Primer: 6-7 Speedhide Block Filler; MDF 10.2 mils.
 - b. Each Finish Coat: 6-411 Speedhide Eggshell Latex; MDF 1.5 mils.
 - 3. Metal: Satin, Water Base, Acrylic Latex.
 - a. Primer: 4020 PF DTM Waterborne Acrylic Prime MDF 2.2 mils.
 - b. Each Finish Coat: 1110 HP Series DTM Acrylic Satin; MDF 1.5 mils.
 - 4. Wood: Satin, Water Base, Acrylic Latex.
 - a. Primer: 17-921XI 100 Percent Acrylic Universal Primer; MDF 1.5 mils.
 - b. Each Finish Coat: 90-1110 DTM Acrylic Satin; MDF 1.5 mils.
 - 5. Concrete: Semi-Gloss, Water Base, Acrylic Latex.
 - a. Primer: 6-7 Speedhide Block Filler; MDF 10.2 mils.
 - b. Each Finish Coat: 6-500 Speedhide Semi-Gloss Latex; MDF 1.2 mils.
 - 6. Ferrous Metal: Semi-Gloss, Water Base, Acrylic Latex.
 - a. Each Finish Coat: 90-474 DTM Acrylic Satin; MDF 1.5 mils.
 - 7. Wood Cabinets and Wood Shelves: Semi-Gloss, Water Base, Acrylic Latex.
 - a. Primer/Sealer: 17-921XI 100 Percent Acrylic Universal Primer; MDF 1.5 mils.
 - b. Each Finish Coat: 90-474 DTM Acrylic Satin; MDF 1.5 mils.
- C. Sherwin Williams:
- 1. Gypsum Board: Zero VOC, Eggshell, Water Base, Acrylic Latex.
 - a. Primer: ProMar 200 Zero VOC Primer, B28W2600, MDF 1.0 mils.
 - b. Each Finish Coat: Scuff Tuff Eggshell, S24-50 Series MDF 1.6 mils.
 - 2. Masonry: Semi-Gloss, Water Base, Acrylic Latex.
 - a. Primer: PrepRite Interior/Exterior Block Filler, B25W25; MDF 3.0 mils.
 - b. Two Finish Coats: ProMar 200 HP Zero VOC Interior Latex Semi-Gloss, B31W1950 Series; MDF 1.5 mils.
 - 3. Metal: Semi-Gloss, Water Base, Acrylic Latex.
 - a. Each Finish Coat: Pro Industrial DTM Acrylic S-G, B66-1151 Series; MDF 3.0 mils.
 - 4. Wood: Semi-Gloss, Water Base, Acrylic Latex.
 - a. Primer: Wall & Wood Primer, B28W08111, MDF 1.6 mils.
 - b. Each Finish Coat: Pro Industrial Waterborne Alkyd Urethane S-G, B53-1150 Series MDF 1.4 mils.
 - 5. Concrete: Semi-Gloss, Water Base, Acrylic Latex.
 - a. Primer: Loxon Concrete & Masonry Primer; MDF 10.0 mils.
 - b. Each Finish Coat: Pro Industrial Waterborne Alkyd Urethane S-G B53-1150 Series, MDF 1.4 mils.
 - 6. Ferrous Metal: Semi-Gloss, Water Base, Acrylic Latex.
 - a. Primer: Pro-Cryl Universal Water Based Primer, B66-1310 Series, MDF 3.0 mils.
 - b. Each Finish Coat: Pro Industrial DTM Acrylic S-G, B66-01151 Series; MDF 3.0 mils.
 - 7. Wood Cabinets and Wood Shelves: Semi-Gloss, Water Base, Acrylic Latex.
 - a. Primer/Sealer: Wall & Wood Primer, B2808111, MDF 1.6 mils.
 - b. Each Finish Coat: Pro Industrial Waterborne Alkyd Urethane S-G B53-1150 Series, MDF 1.4 mils.

2.5 INTERIOR LEAD ENCAPSULATING COATINGS

- A. Product: Lead encapsulating coating as manufactured by Benjamin Moore.
 - 1. Benjamin Moore: Insl-X Lead Block, Lead Encapsulating Coating, Eggshell EC-3210.
 - a. Base Coat: to be applied over properly prepared substrates of drywall, plaster, wood, masonry or metal surfaces for walls, trim and ceilings, MDF 14-16 mils wet. Do not use on surfaces that may be exposed to friction wear. Compatible finish coats may be applied. Prepare and install base coat per manufacturer's recommendations.

PART 3 - EXECUTION

3.1 EXAMINATION

- A. Section 017300 - Execution: Verification of existing conditions before starting work.
- B. Verification of Conditions: Verify that field measurements, surfaces, substrates and conditions are as required, and ready to receive Work.
- C. Report in writing to USPS Project Manager prevailing conditions that will adversely affect satisfactory execution of the Work of this Section. Do not proceed with Work until unsatisfactory conditions have been corrected.
- D. By beginning Work, Contractor accepts conditions and assumes responsibility for correcting unsuitable conditions encountered at no additional cost to the United States Postal Service.

3.2 PREPARATION

- A. Do not paint over dirt, rust, scale, grease, moisture, scuffed surfaces, and conditions otherwise detrimental to formation of a durable paint film.
- B. Perform preparation and cleaning procedures in accordance with paint manufacturer's published instructions for each particular substrate condition.
 - 1. Provide barrier coats over incompatible primers or remove and reprime as required.
 - 2. Remove hardware, hardware accessories, machined surfaces, plates, lighting fixtures, and similar items in place and not to be painted or provide surface applied protection prior to surface preparation and painting operations. Reinstall all removed items after completion of paint work.
 - 3. Clean surfaces to be painted before applying paint of surface treatment. Remove oil and grease prior to mechanical cleaning.
- C. Ferrous Metals: Clean ferrous surfaces that are not galvanized or shop-coated, of oil, grease, dirt, loose mill scale and other foreign substances by solvent or mechanical cleaning.
 - 1. Touch-up shop-applied prime coats, where damaged or bare. Clean and touch-up with same type shop primer.
- D. Galvanized Surfaces: Clean free of oil and surface contaminants with non-petroleum-based solvent. Apply coat of etching primer if required by paint manufacturer.
- E. Cementitious Materials: Prepare cementitious surfaces to be painted by removing efflorescence, chalk, dust, dirt, grease, oils, and by roughening as required to remove glaze.
 - 1. Determine alkalinity and moisture content of surfaces to be painted by performing appropriate tests.
 - a. If surfaces are found to be sufficiently alkaline to cause blistering and burning of finish paint, correct condition before application of paint.
 - 2. Do not paint over surfaces where moisture content exceeds that permitted in manufacturer's printed instructions.

3. Clean floor surfaces scheduled to be painted with a commercial solution of muriatic acid, or other etching cleaner. Flush floor with clean water to neutralize acid and allow to dry before painting.
- F. Wood: Clean wood surfaces to be painted of dirt, oil, and other foreign substances with scrapers, mineral spirits, and sandpaper, as required. Sandpaper smooth those finished surfaces exposed to view and dust off. Scrape and clean small, dry, seasoned knots and apply a thin coat of white shellac or other recommended knot sealer, before application of priming coat. After priming, fill holes, and imperfections in finish surfaces with putty or plastic wood-filler. Sandpaper smooth when dried.
 1. Prime, stain, or seal wood required to be job-painted immediately upon delivery to job. Prime edges, ends faces, undersides, and backsides of such wood, including cabinets and counters.
 2. Seal tops, bottoms, and cut-outs with a heavy coat of varnish or equivalent sealer immediately upon delivery to job.
- G. Gypsum Board: Fill minor defects with filler compound. Spot prime defects after repair.

3.3 APPLICATION

- A. Apply paint products in accordance with manufacturer's published instructions using application procedures approved for the particular application and substrate to the specified Minimum Dry Film Thickness (MDF). Apply each coat to uniform finish.
- B. Apply each coat slightly darker than preceding coat unless otherwise approved by USPS Project Manager. Sand lightly between coats to achieve specified finish.
- C. Do not apply finishes on surfaces that are not dry.
- D. Number of coats and film thickness required is same regardless of application method. Do not apply succeeding coats until the previous coat has cured as recommended by the manufacturer.
- E. Apply additional coats when undercoats, stains, or other conditions show through final coat until paint film is of uniform finish, color, and appearance. Surfaces, including edges, corners, crevices, welds, and exposed fasteners to receive minimum dry film thickness equivalent to that of flat surfaces.
- F. Minimum Coating Thickness: Apply materials at not less than manufacturer's recommended spreading rate. Provide minimum dry film thickness (MDF) of the entire coating system as indicated in Painting and Finishing Schedule at end of this Section.
- G. Block Fillers: Apply block fillers to concrete masonry units at rate to provide complete coverage with pores filled.
- H. Prime Coats: Before application of finish coats, apply a prime coat of material as recommended by manufacturer to material scheduled to be painted or finished that has not been shop primed. Recoat primed and sealed surfaces where evidence of suction spots or unsealed areas in first coat appears, to assure a finish coat with no burn through or other defects due to insufficient sealing.
- I. Pigmented (Opaque) Finishes: Completely cover to provide an opaque, smooth surface of uniform finish, color, appearance, and coverage. Cloudiness, spotting, laps, brush marks, runs, sags, or other surface imperfections will not be acceptable.
- J. Hollow Metal Doors: Paint each door edge.
- K. Completed Work: Match USPS Project Manager approved field samples for color and sheen.

3.4 MECHANICAL AND ELECTRICAL EQUIPMENT

- A. Clean or replace identification markings on mechanical or electrical equipment when painted over or spattered.
- B. Paint both sides and edges of plywood backboards for electrical equipment before installing backboards and mounting equipment on them.
- C. Pre-paint Gas piping prior to installation. (Touch-up paint after installation.)
 - 1. Color:
 - a. Roof (Yellow): OSHA Standard "Safety Yellow."
 - b. Other Areas: Match adjacent surfaces.
- D. At Workroom locations, paint red background on wall and columns behind fire extinguisher extending 6 inches on both sides of the extinguisher and from floor to ceiling, or to 12 feet above floor, whichever is lower. Color is to be OSHA Standard "Safety Red" and in accordance with ANSI Z53.1.

3.5 FIELD QUALITY CONTROL

- A. Section 014000 - Quality Requirements: Field testing and inspection.
- B. Inspect painting and coating application for scheduled material, color, sheen, specified thickness (MDF), and coverage.

3.6 CLEANING

- A. As work proceeds and upon completion, promptly remove paint where spilled, splashed, or spattered.
- B. During progress of work keep premises free from any unnecessary accumulation of tools, equipment, surplus materials, and debris.
- C. Collect waste, cloths, and material which may constitute a fire hazard, place in closed metal containers and remove daily from site.
- D. Upon completion of work leave premises neat and clean.

3.7 PROTECTION

- A. Protect other surfaces from paint and damage. Repair damage as a result of inadequate or unsuitable protection.

3.8 COLOR SCHEDULE

- A. Any proposal to substitute a color is to include manufacturer's certification that the color matches the specified Munsell notation, or Pantone Color Matching System (PMS) number.
- B. P-1 White (Munsell notation: #5Y 9.25/0.5NN)
 - 1. Benjamin Moore: #968, Dune White.
 - 2. PPG Paints: #512-1, Winter Mood.
 - 3. Sherwin-Williams: #SW 7636, Origami White
- C. P-2 Light Gray (Munsell notation: #N8.0)
 - 1. Benjamin Moore: #1612 Pelican Gray.

- 2. Sherwin-Williams: #SW 7662, Evening Shadow
- D. P-3 (Not Used)
- E. P-4 Red (Match PMS 485C "Postal Red") Custom Match
- A. P-5 Blue (Match PMS 301C "Postal Blue") Custom Match
- B. P-6 Medium Gray (Munsell notation: #10B7/1)
 - 1. Sherwin Williams: SW#1232, Dublin Gray (custom mix)
- C. P-7 Semi-gloss Black

3.9 SCHEDULE OF ITEMS TO BE PAINTED

- A. Painted finishes shall be provided for, but not limited to, the following items. Refer to Drawings and Paint Color Schedule above for designated finishes and colors of areas.
 - 1. Exterior: All exterior surfaces as indicated on Drawings. Verify items listed below as required.:
 - a. Hollow metal doors and frames.
 - b. Metal opening frames and trim.
 - c. Metal flashing (if exposed from ground level) and downspout.
 - d. Metal gravelstops (vertical face).
 - e. Pipe Bollards, if not to receive plastic covers specified in Section 055000.
 - f. Metal railings.
 - g. Roof hatch.
 - h. Canopy supporting steel structure.
 - i. Wall louvers.
 - j. Exposed concrete.
 - k. Exposed concrete masonry.
 - l. Stucco/cement plaster.
 - 2. Interior: All interior surfaces as indicated on Drawings. Verify items listed below as required.
 - a. Hollow metal doors and frames.
 - b. Hollow metal window frames.
 - c. Metal opening frames and trim.
 - d. Gypsum wallboard.
 - e. Exposed concrete unit masonry.
 - f. Pipe Bollards.
 - g. Metal railings.
 - h. Exposed structure columns.
 - i. Metal stair stringers and handrails.
 - j. Exposed wood trim.
 - k. Wall louvers.
 - l.
- B. Do not paint the following items:
 - 1. Pre-finished items:
 - a. Aluminum, brass, bronze, stainless steel, and chrome plated steel.
 - b. Pre-finished items, such as toilet compartments, acoustical ceiling materials, mechanical, and electrical equipment.
 - c. UL, FM, and other code-required labels.
 - d. Equipment identification, performance rating, and name plates.
 - e. Finish hardware.
 - f. Factory finished metal wall panels, metal wall panel trim, and metal gravel stops.

2. Exposed items:
 - a. Exposed mechanical ductwork, hangers, and supports.
 - b. Exposed piping ~~and conduit~~, hangers and supports.
 - c. Exposed fire protection piping, hangers and supports.

3.10 PAINTING AND FINISHING SCHEDULE

A. Interior Paint Systems:

1. Interior Gypsum Wallboard:
 - a. 1 coat Latex Wall Primer.
 - b. 1 coat Latex Eggshell Enamel
2. Interior Gypsum Wallboard Painted P-4 and P-5:
 - a. 1 coat Latex Wall Primer
 - b. 5 coats Latex Eggshell Enamel
3. Interior Masonry:
 - a. 1 coat Latex Block Filler
 - b. 1 coat Latex Eggshell Enamel
4. Interior Metal:
 - a. 2 coats Latex Satin
5. Interior Wood (painted):
 - a. 1 coat Enamel Undercoat
 - b. 2 coats Alkyd Semi-Satin Enamel
6. Cast-In-Place Concrete:
 - a. One coat of Latex Masonry Block Filler.
 - b. Two tinted coats of Acrylic Latex Semi-Gloss Enamel.
7. Wood Doors - Painted.
 - a. One coat Enamel Undercoat.
 - b. Two tinted coats of Latex Semi-Gloss Enamel.
8. Ferrous Metals
 - a. Touch up Prime Coat.
 - b. Two tinted coats of Alkyd Enamel Semi-Gloss.
9. Wood Cabinets, Shelves, etc. - exposed surfaces.
 - a. One coat Primer-Sealer.
 - b. One coat Enamel Undercoat.
 - c. One coat Alkyd Enamel Semi-Gloss Enamel.
10. Epoxy Concrete Floor System (VMF Service Bay)
 - a. One coat Primer
 - b. One coat Epoxy 100% solids
 - c. Option One coat Urethane

B. Exterior Paint Systems:

1. Galvanized Metal:
 - a. Touch up Prime Coat.
 - b. Two tinted coats Exterior Alkyd Enamel Semi-Gloss Enamel.
2. Ferrous Metals:
 - a. Touch up Prime Coat.
 - b. Two tinted coats Exterior Alkyd Enamel Semi-Gloss Enamel.
3. Concrete/Masonry/Stucco
 - a. Prime Coat.
 - b. Two tinted coats Exterior Acrylic Latex Semi-Gloss.

END OF SECTION

SECTION 101404

POSTAL SIGNAGE

PART 1 – GENERAL

1.1 SUMMARY

- A. Exterior signage – building identification, directional and parking regulatory signs.
- B. Department of Transportation (DOT) traffic control signs.
- C. Monument signage.

1.2 SUBMITTALS

- A. Product data: Required
- B. Shop drawings: Required

1.3 QUALITY CONTROL

- A. Installer's certification of minimum five years documented experience.
- B. DOT traffic signs shall be in compliance with all state and local codes and ordinances.

PART 2 - PRODUCTS

2.1 MANUFACTURERS

- A. Exterior Building Signage: Building identification:
 - 1. This Product must be manufactured by a USPS Direct Vendor and is subject to a USPS price and requirements purchasing agreement. The following vendor must be used:
 - a. Gable Signs & Graphics, Inc., 7440 Fort Smallwood Rd, Baltimore, MD 21226, (877) 311-8777, usps@gablecompany.com.
- B. Exterior Site Signage: Directional and parking regulatory signs:
 - 1. This Product must be manufactured by a USPS Direct Vendor and is subject to a USPS price and requirements purchasing agreement. The following vendor must be used:
 - a. Gable Signs & Graphics, Inc., 7440 Fort Smallwood Rd, Baltimore, MD 21226, (877) 311-8777, usps@gablecompany.com.
- C. Exterior Monument Signage:
 - 1. This Product must be manufactured by a USPS Direct Vendor and is subject to a USPS price and requirements purchasing agreement. The following vendor must be used:
 - a. Gable Signs & Graphics, Inc., 7440 Fort Smallwood Rd, Baltimore, MD 21226, (877) 311-8777, usps@gablecompany.com.
- D. DOT Traffic Control Signs:
 - 1. Sign posts shall be galvanized heavy steel hat channels.
 - 2. Sign face background shall be 0.063 inch aluminum plate, cut to size and attached to sign post with non-corrosive 3/8" machine bolts with washers, two per sign.

- E. Interior Signage – Retail signage, Passport signage, etc.:
 - 1. This Product must be manufactured by a USPS Direct Vendor and is subject to a USPS price and requirements purchasing agreement. The following vendor must be used:
 - a. Gable Signs & Graphics, Inc., 7440 Fort Smallwood Rd, Baltimore, MD 21226, (877) 311-8777, usps@gablecompany.com.

PART 3 – EXECUTION

- 3.1 Install all products in accordance with manufacturer’s guidelines and printed instructions.

END OF SECTION

USPS MPF Specification Last Revised: 10/1/2022

SECTION 260500

COMMON WORK RESULTS FOR ELECTRICAL

PART 1 - GENERAL

1.1 SUMMARY

- A. Section includes:
 - 1. Basic electrical methods.
 - 2. Grounding and bonding.
 - 3. Hangers and supports.
 - 4. Electrical identification.
 - 5. Motor starters, controls, and connections to mechanical equipment.
 - 6. Electrical system testing and inspection.

- B. Related Documents: The contract documents, as defined in Section 011000 – Summary of Work, apply to the work of this section. Additional requirements and information necessary to complete the work of this section may be found in other documents.

- C. Related Sections:
 - 1. Section 019113 - General Commissioning Requirements
 - 2. Section 024113 - Selective Site Demolition
 - 3. Section 078400 - Firestopping
 - 4. Section 260519 - Low-Voltage Electrical Power Conductors and Cables
 - 5. Section 260533 - Raceway and Boxes for Electrical Systems
 - 6. Section 260623 - Lighting Control Devices
 - 7. Section 262200 - Low Voltage Transformers
 - 8. Section 262416 - Panelboards
 - 9. Section 262726 - Wiring Devices
 - 10. Section 262816 - Enclosed Switches and Circuit Breakers
 - 11. Section 265100 - Interior Lighting (LED - Solid State)
 - 12. Section 265600 - Exterior Lighting
 - 13. Section 312000 - Earth Moving
 - 14. Section 312300 - Excavation and Fill

1.2 REFERENCES

- A. National Electrical Contractors Association (NECA):
 - 1. NECA SI - Standard of Installation.

- B. National Electrical Manufacturers Association (NEMA):
 - 1. NEMA KS 1 - Enclosed Switches.

- C. National Electrical Testing Association (NETA):
 - 1. NETA ATS - Acceptance Testing Specifications for Electrical Power Distribution Equipment and Systems.

- D. National Fire Protection Association (NFPA):
 - 1. NFPA 70 - National Electrical Code.

1.3 SUBMITTALS

- A. Section 013300 - Submittal Procedures: Procedures for submittals.
 - 1. Product Data:
 - a. Grounding electrodes and connections.
 - b. Starter electrical characteristics and connection requirements.
 - 2. Assurance/Control Submittals:
 - a. Electrical System Test Reports: Submit report including the following directly to the USPS Project Manager from Testing Laboratory, with copy to Contractor. Prepare reports in conformance with Section 014000 - Quality Requirements.
 - b. Summary of project.
 - c. Description of equipment tested.
 - d. Description of test.
 - e. Test results.
 - f. Conclusions and recommendations.
 - g. Appendix, including appropriate test forms.
 - h. List of test equipment used and calibration date.
 - i. Signature of responsible Testing Laboratory Officer.
 - j. Certificates: Manufacturer's certificate that each Product specified meet or exceed specified requirements.
 - k. Qualification Documentation: Submit documentation of experience indication compliance with specified qualification requirements.
- B. Section 017704 - Closeout Procedures and Training: Procedures for closeout submittals.
 - 1. Project Record Documents: Accurately record the following.
 - a. Locations of components and grounding electrodes.

1.4 QUALITY ASSURANCE

- A. Installer Qualifications: Company specializing in performing Work of this Section with minimum 5 years documented experience.
- B. Regulatory Requirements:
 - 1. Products: Listed and classified by Underwriters Laboratories, Incorporated as suitable for the purpose specified and indicated.
 - 2. Work herein shall conform to all applicable laws, ordinances and regulations in accordance with the latest applicable requirements of:
 - a. The National Electrical Code (NFPA 70).
 - b. National Electrical Manufacturer's Associates.
 - c. Standards of National Fire Protection Association (NFPA 72, 90A and 101).
 - d. Underwriter's Laboratories.
 - e. Occupational Safety and Health Agency Standards.
 - f. Illuminating Engineering Society Handbook.
 - g. The International Existing Building Code.
 - h. The International Electrical Code.
 - i. ASHRAE Standard 90.1.
 - j. The International Energy Conservation Code.

1.5 BASIC ELECTRICAL METHODS

- A. Drawings are schematic and diagrammatic. Use judgment and care to install electrical Work to function properly and fit within building construction and finishes. Electrical conductors, conduit, components, not shown or specified, which are required for any device or system to produce a complete and operative system are required to be furnished and installed.

- B. Exact location of outlets is determined from dimension on Drawings, manufacturer's shop drawings, or as may be determined at Project Site. Do not scale Drawings for exact location of any item. Verify item mounting heights as required by project conditions prior to rough-in.
- C. Route conduits and wiring associated with new equipment and systems above ceilings, in existing chases, and concealed within building structure.
- D. Surface mounted raceways or conduit permitted only at locations indicated on Drawings.
- E. Circuit grouping, conduit or cable runs and home runs are indicated with number of conductors shown in each raceway to clarify operation and function of various systems. Provide proper number of conductors and conduits or cables to provide operative system as indicated on Contract Documents. Do not regroup any feeder circuits, branch circuits, home runs, and zone alarms at any point, from that shown on Contract Documents. Each conduit run shall contain no more than (6) current carrying conductors.
- F. Branch and home run circuits are indicated as 2, 3, or 4 wire circuits unless otherwise noted. Do not connect two ungrounded conductors to same circuit breaker/fused switch in any panel. Circuit runs consist of a maximum of five conductors; 3 phase conductors, 1 neutral conductor, and 1 equipment ground conductor, unless otherwise noted. Do not splice branch circuit conductors in any panels, safety switches, or circuit breakers in separate enclosures.
- G. The sharing of neutral conductors for multiwire branch circuits is prohibited. All branch circuits shall contain individual neutrals.
- H. Proposed equipment, switches or devices, shown mounted on and/or adjacent to equipment, which if installed, would impair proper operation of existing or new equipment, shall be removed and relocated by Contractor as required so equipment will function properly. Notify Contracting Officer immediately if any such condition exists.
- I. Seal and make permanently watertight penetrations by electrical raceways or equipment through ceilings, walls or floors.
 - 1. Seal penetrations in non-fire rated ceilings, walls or floors material specified in Section 079200 – Joint Sealants.
 - 2. Seal penetrations in fire rated walls with material specified in Section 078400 - Firestopping.
- J. Tighten electrical connectors and terminals, including screws and bolts, in accordance with equipment manufacturer's published torque tightening values for equipment connectors. Where manufacturer's torqueing requirements are not indicated, tighten connectors and terminals to comply with tightening torques specified in UL 486A, and NFPA 70.
- K. Install equipment and materials to provide required maintenance and code working clearance for servicing and maintenance. Coordinate final location of concealed equipment and devices requiring access with final location of required access panels and doors. Allow required space for removal of parts that require replacement or servicing.
- L. Remove existing equipment, lighting fixtures, switches, and receptacles as required to facilitate proposed installation and as specified in Section 024119 - Selective Structure Demolition. Remove existing wiring and conduit serving items to be removed. Conduit in inaccessible areas shall be cut off below finished surfaces and existing surface patched to match existing. Provide blank plates on existing flush mounted outlet boxes that will be abandoned. Remove all abandoned conductors from raceways.

PART 2 - PRODUCTS

2.1 GROUNDING AND BONDING

- A. Grounding System Resistance: Five ohm.
- B. Rod Electrodes:
 - 1. Material: Copper.
 - 2. Diameter: 3/4 inch.
 - 3. Length: 10 feet.
- C. Mechanical Connectors: Bronze.
- D. Electrode Conductor:
 - 1. Material: Bare stranded copper.
 - 2. Grounding Electrode Conductor: Size to meet NFPA 70 requirements.

2.2 HANGERS AND SUPPORTS

- A. Product Requirements: Furnish and install approved materials, sizes, and types of anchors, fasteners, and supports to carry loads of equipment and conduit, including weight of wire in conduit plus 300 pounds.
- B. Materials and Finishes: Corrosion resistive.
- C. Anchors and Fasteners:
 - 1. Steel Structural Elements: Beam clamps and welded fasteners.
 - 2. Concrete Surfaces: Self-drilling anchors and expansion anchors.
 - 3. Hollow Masonry, Plaster, and Gypsum Board Partitions: Toggle bolts and hollow wall fasteners.
 - 4. Solid Masonry Walls: Expansion anchors.
 - 5. Sheet Metal: Sheet metal screws.
 - 6. Wood: Wood screws.

2.3 ELECTRICAL IDENTIFICATION

- A. Nameplates:
 - 1. Engraved three-layer laminated phenolic plastic, white letters on black background.
 - 2. Locations:
 - a. Each electrical distribution and control equipment enclosure.
 - b. Communication cabinets.
 - c. Terminal Cabinets.
 - d. Individual motor starter.
 - e. Separately enclosed circuit breakers.
 - f. Panelboards
 - g. Transformers.
 - h. Pull boxes.
 - i. Lighting contactor/control panel enclosure.
 - j. Relays.
 - k. Switches and disconnects.
 - 3. Letter Size:
 - a. Use 1/8 inch letters for identifying individual equipment and loads.
 - b. Use 1/4 inch letters for identifying grouped equipment and loads.

- B. Wire and Cable Markers:
1. Description: Cloth tape or tubing type wire markers.
 2. Locations: Each conductor at panelboard gutters, pull boxes, outlet and junction boxes, and each load connection.
 3. Identification:
 - a. Power and Lighting Circuits: Branch circuit or feeder number indicated on Drawings.
 - b. Control Circuits: Control wire number indicated on schematic and interconnection diagrams on Drawings.
 - c. Communications Cable: Per section 270500.
- C. Conduit Markers:
1. Underground conduit routings shall be marked utilizing magnetic marker tape set atop of the entire conduit run.
 - a. Underground-Type Plastic Line Marker: Manufacturer's standard detectable permanent, bright colored, continuous-printed plastic tape, intended for direct-burial service; not less than 6 inches wide by 4 mils thick. Provide tape with printing which most accurately indicates type of service of buried cable. Locate tape **1 foot below finished grade**
 2. Detectable marker tape cannot be installed atop of directionally bored underground conduits. Directionally bored conduits containing only fiber cabling shall therefore be equipped with a #12/AWG copper conductor to enhance detection.
- D. Arc Flash Warning Signs: Furnish signs in accordance with NEC Article 110.16, warning of potential arc flash hazard and requiring suitable Personal protective equipment. Locate and install signs per INSTALLATION Section of this specification.
- E. Confined space markings: Work within electrical manholes and underground vaults must comply with "confined space" OSHA requirements. Manhole covers and the entrance to underground vaults shall be stamped or marked as "CONFINED SPACE – PERMIT REQUIRED".
- F. Receptacles and Switches: All coverplates for receptacles and switches shall be labeled with the branch circuit number. Label shall be machine generated and permanently affixed to the outside of the coverplate.

2.4 MOTOR STARTERS, CONTROLS, AND CONNECTIONS TO MECHANICAL EQUIPMENT

The only motor connections anticipated for the VMF program are to new vehicle lifts and new overhead door operators within scope of work. Refer to drawings for quantity of lifts and overhead doors in scope.

- A. Manufacturers: Subject to compliance with project requirements, manufacturers offering Products which may be incorporated in the Work include the following:
1. ABB/G.E. Industrial Solutions (ABB/GEIS), Mebane, NC (800) 431-7867.
 2. Allen-Bradley Company, Milwaukee, WI (414) 382-2000.
 3. Cutler-Hammer Eaton Corp, Milwaukee, WI (800) 833-3927.
 4. Square D Company, Palatine, IL (847) 397-2600.
 5. Siemens Energy and Automation, Alpharetta, GA (800) 964-4114.
 6. Overhead door, Lewisville, TX (800) 929-3667
 7. Section 016000 - Product Requirements: Product options and substitutions. Substitutions: Permitted.
- B. Furnish and Install the Following:
1. Conduit, wiring and electrical connections to motors, safety switches, starters, relays, electrical interlock circuits, valves, unit heaters, fan coil units, air handling units, and other similar equipment, required for complete and ready for operation. Coordinate with and review other sections of the specifications describing electrical equipment in order to fully understand the wiring requirements.
 2. Starters as indicated on Drawings except factory provided starters such as those physically mounted on the unit or any piece of equipment where starter is furnished as an integral part of the equipment.
 3. Electrical line voltage control components and installation as specified in Division 26 Sections.

4. Furnish and install low voltage (below 50 volts) control wiring as indicated on Drawings using metallic conduit and No. 12 type THHN wire, minimum.
 5. Thermostat and special wire other than building wire.
- C. Refer to Drawings for quantity and size of motor starters.
- D. Individual and group mounted motor starters within motor control centers and those starters factory provided integral with the equipment shall be furnished in accordance with paragraph 2.4 B.

PART 3 - EXECUTION

3.1 EXAMINATION

- A. Section 017300 - Execution: Verification of existing conditions before starting work.
- B. Verification of Conditions: Verify that field measurements, surfaces, substrates and conditions are as required, and ready to receive Work.
- C. Report in writing to the USPS Project Manager prevailing conditions that will adversely affect satisfactory execution of the Work of this Section. Do not proceed with Work until unsatisfactory conditions have been corrected.
- D. By beginning Work, Contractor accepts conditions and assumes responsibility for correcting unsuitable conditions encountered at no additional cost to the United States Postal Service.

3.2 INSTALLATION - GROUNDING AND BONDING

- A. Install rod electrodes at locations indicated. Install additional rod electrodes as required to achieve specified resistance to ground.
- B. Provide grounding electrode conductor and connect to reinforcing steel in foundation footing, building steel above grade and metallic cold water pipe.
- C. Provide bonding and grounding in conformance with NFPA 70.
- D. Equipment Grounding Conductor: Provide separate, insulated conductor within all lighting and power raceways. Terminate each end on suitable lug, bus, or bushing.
- E. Testing and Inspection:
 1. Inspect and test in accordance with NETA ATS, where applicable.
 2. Perform inspections and tests listed in NETA ATS, Section 7.13.
 3. Test ground resistance of system with clamp-on ground resistance tester. The resistance of the grounding system shall not exceed 5 ohms. Where tests show resistance-to-ground is over 5 ohms, take appropriate action to reduce resistance to 5 ohms, or less, by driving additional ground rods, lengthening the rods or installing ground enhancing materials; then retest to demonstrate compliance. Install rods at least 8 feet apart.

3.3 INSTALLATION - HANGERS AND SUPPORTS

- A. Install products in accordance with manufacturer's published instructions.
- B. Furnish and install anchors, fasteners, and supports in accordance with NECA SI.

- C. Do not fasten supports to pipes, ducts, mechanical equipment, and conduit.
- D. Do not use spring steel clips and clamps.
- E. Do not use powder-actuated anchors.
- F. Obtain permission from structural engineer before drilling or cutting structural members.
- G. Fabricate supports from structural steel angle or structural steel channel. Rigidly weld members or use hexagon head bolts to present neat appearance with adequate strength and rigidity. Use spring lock washers under all nuts.
- H. Install surface-mounted cabinets and panelboards with minimum of four anchors.
- I. In wet and damp locations use structural steel channel supports to stand cabinets and panelboards one inch off wall.
- J. Use sheet metal channel to bridge studs above and below cabinets and panelboards recessed in hollow partitions.

3.4 INSTALLATION - ELECTRICAL IDENTIFICATION

- A. Install nameplate parallel to equipment lines.
- B. Secure nameplate to equipment front using stainless steel screws. Use minimum two screws at each end of nameplate.
- C. Secure nameplate to outside surface of door on panelboards and switchboards.
- D. Install Arc Flash Warning Signs on switchboards, panelboards, control panels, meter socket enclosures, and motor control centers likely to require examination, adjustment, servicing, or maintenance while energized. Locate sign so as to be clearly visible to qualified persons before examination, adjustment, servicing, or maintenance of the equipment.

3.5 INSTALLATION – MOTOR STARTERS, CONTROLS, AND CONNECTIONS TO MECHANICAL EQUIPMENT

- A. Verify and check equipment manufacturer's nameplate and installation instructions to obtain exact location of outlets for equipment before installation.
- B. Wire and connect line voltage controls in accordance with approved wiring diagrams. Provide line voltage interlock and control wiring as indicated on Drawings using conduit and No. 12 type THHN wire.
- C. **The only motor connection anticipated for the VMF program are to new vehicle lifts and overhead doors operator within scope of work. Refer to drawings for quantity of lifts and overhead doors in scope.**

3.6 FIELD QUALITY CONTROL - ELECTRICAL TESTING AND INSPECTION

- A. Section 014000 - Quality Requirements: Field testing and inspection.
- B. Section 260800 - Commissioning of Electrical Systems: Requirements related to Division 26 Commissioning

- C. Conduct testing to Determine that Electrical Equipment and Systems:
 - 1. Are in conformance with Contract Documents and applicable reference standards.
 - 2. Is properly installed without damage due either to installation or shipment.
 - 3. Operate correctly, meet design intent, and are performing at optimum level, in safe manner.

- D. Provide a complete written record of operational values to be used as a baseline for future operational testing.

- E. Instrumentation:
 - 1. Provide calibration program that assures applicable test instrumentation is maintained within rated accuracy and directly traceable to National Bureau of Standards.
 - 2. Calibrate instruments in accordance with following frequency schedule:
 - a. Field Instruments:
 - b. Analog - 6 months maximum.
 - c. Digital - 12 months maximum.
 - d. Leased Specialty Equipment: 12 months. (Where accuracy is guaranteed by lessor.)
 - 3. Dated Calibration Labels: Visible on test equipment.
 - 4. Keep records current; Show date and result of instruments calibrated or tested.
 - 5. Maintain current instrument calibration instruction and procedure for each test instrument.
 - 6. Calibrating Standard: Higher accuracy than that of instrument being calibrated.

- F. Regulatory Requirements:
 - 1. Safety Practices: Include, but not limited to, the following requirements:
 - a. Occupational Safety and Health Act of 1970 - OSHA.
 - b. Accident Prevention Manual for Industrial Operations, Seventh Edition, National Safety Council, Chapter 4.
 - c. Applicable State and Local Safety Operating Procedures.
 - d. NETA Safety/Accident Prevention Program.
 - e. United States Postal Service Safety Practices.
 - f. NFPA 70E - Electrical Safety Requirements for Employee Workplace.
 - g. American National Standards for Personnel Protection, ANSI Z244.1.
 - 2. Perform tests with apparatus de-energized except where otherwise specifically required herein.
 - 3. Testing Laboratory: Provide a designated safety representative present at Project Site and supervise safety operations.
 - 4. Power Circuits: Conductors shorted to ground by a hot line grounded device approved for the purpose.
 - 5. Do not proceed until safety representative has determined that it is safe to do so.
 - 6. Testing Laboratory: Provide sufficient protective barriers and warning signs to conduct specified tests safely.

- G. Tests and inspections include, but are not limited to the following:
 - 1. Proper operation of lights and equipment.
 - 2. Continuity of raceway system.
 - 3. Insulation leakage and impedances.

- H. Load balance all electrical phases, at device, panels, and switchboards.

- I. Perform electrical system testing and inspection as specified in each related Section and as specified in this Section.

END OF SECTION

USPS MPF Specification Last Revised: 10/1/2022

SECTION 260519

LOW-VOLTAGE ELECTRICAL POWER CONDUCTORS AND CABLES

PART 1 - GENERAL

1.1 SUMMARY:

A. Section Includes:

1. Building wire and cable.
2. Branch-circuit cable.
3. Wiring connectors and connections.
4. Drop cords.
5. Busways.

B. Related Documents: The Contract Documents, as defined in Section 011000 - Summary of Work, apply to the Work of this Section. Additional requirements and information necessary to complete the Work of this Section may be found in other documents.

C. Related Sections:

1. As specified in Section 260500 - Common Work Results for Electrical: Basic electrical methods.

1.2 REFERENCES

- A. As specified in Section 260500 – Common Work Results for Electrical.

1.3 SUBMITTALS

- A. As specified in Section 260500 - Common Work Results for Electrical.

1.4 QUALITY ASSURANCE

- A. As specified in Section 260500 – Common Work Results for Electrical.

1.5 DELIVERY, STORAGE, AND HANDLING

- A. Section 016000 - Product Requirements: Transport, handle, store, and protect products.
- B. Deliver in accordance with NEMA WC 26.

PART 2 - PRODUCTS

2.1 BUILDING WIRE AND CABLE

A. Manufacturers: Subject to compliance with project requirements, manufacturers offering Products which may be incorporated in the Work include the following:

1. Alcan Cable, Atlanta, GA (770) 392-2376.
2. Anixter, Inc., Skokie, IL (800) ANIXTER.

3. General Cable, Highland Heights, KY (800) 526-4391.
4. General Electric, Plainville, CT (860) 747-7111.
5. Okonite, Ramsey, NJ (201) 825-0300.
6. Southwire Company, Carrollton, GA (800) 444-1700.
7. Section 016000 - Product Requirements: Product options and substitutions. Substitutions: Permitted.

B. Description: Single conductor insulated wire.

C. Conductor: Copper, except conductors #1/0 AWG and larger may be compact stranded aluminum if equipped with compression lugs and installed per manufacturer's recommendations and the National Electrical Code.

D. Insulation Voltage Rating: 600 Volts.

E. Insulation: NFPA 70, Type THHN/THWN or Type XHHW-2.

F. Multiconductor cable: Metal clad cable, Type MC with ground wire.

1. Type "MC" cable shall be permitted for use in exposed or accessible ceiling spaces only. Type "MC" cable shall not be utilized above inaccessible hard ceilings or in damp locations. Cable shall be supported and secured where such support does not exceed 3 ft. intervals and shall be properly color coded to identify phase, neutral, ground and switch legs.

2.2 WIRING CONNECTORS

A. Manufacturers: Subject to compliance with project requirements, manufacturers offering Products which may be incorporated in the Work include the following:

1. Buchanan Construction Products, Hackettstown, NJ (800) 610-5201.
2. Thomas and Betts, Memphis, TN (800) 695-1901.
3. 3M, St. Paul, MN (800) 364-3577.
4. Section 016000 - Product Requirements: Product options and substitutions. Substitutions: Permitted.

B. Compression Connectors; Conductor sizes #12 through #6 AWG:

1. Buchanan: 2006S or 2011S.
2. Thomas and Betts:
3. 3M;

PART 3 - EXECUTION

3.1 EXAMINATION

A. As specified in Section 260500 – Common Work Results for Electrical.

3.2 PREPARATION

A. Completely and thoroughly swab raceway before installing wire.

3.3 INSTALLATION - CONDUCTORS

- A. Wiring methods:
 - 1. Concealed Dry Interior Locations: Use only building wire, Type THHN/THWN or Type XHHW-2 insulation in metallic raceway or MC multiconductor cable.
 - 2. Exposed Dry Interior Locations: Use only building wire, Type THHN/THWN or Type XHHW-2 insulation in metallic raceway or MC multiconductor cable.
 - 3. Above Accessible Ceilings: Use only building wire, Type THHN/THWN or Type XHHW-2 insulation in metallic raceway or MC multiconductor cable.
 - 4. Wet or Damp Interior Locations: Use only building wire, Type THW or THWN or Type XHHW-2 insulation in raceway.
- B. Install products in accordance with manufacturers published instructions and NECA SI.
- C. Use solid conductor for feeders and branch circuits 10 AWG and smaller.
- D. Use stranded conductors for control circuits and final connections to all vibration equipment.
- E. Use conductor not smaller than 12 AWG for power and lighting circuits.
- F. Use conductor not smaller than 14 AWG for control circuits.
- G. Use 10 AWG conductors for 20 ampere, 120 Volt branch circuits longer than 75 feet.
- H. Use 10 AWG conductors for 20 ampere, 277 Volt branch circuits longer than 200 feet.
- I. Pull all conductors into raceway at same time.
- J. Use approved wire pulling lubricant for all building wire.
- K. Protect exposed cable from damage.
- L. Neatly train and lace wiring inside boxes, equipment, and panelboards in accordance with NECA Standards.
- M. Clean conductor surfaces before installing lugs and connectors.
- N. Make splices, taps, and terminations to carry full ampacity of conductors with no perceptible temperature rise.
- O. For splices and taps, use only compression connectors for copper or aluminum conductors, 6 AWG and larger. Tape uninsulated conductors and connector with electrical tape to 150 percent of insulation rating of conductor.
 - 1. Splicing of copper feeder conductors #3 AWG and larger is prohibited.
 - 2. Splicing of aluminum feeder conductors #1 AWG and larger is prohibited.
 - 3. Splices within branch circuit or feeder conductors located underground or below grade shall not be provided. All splices shall be terminated above grade.
- P. Use solderless pressure compression connectors with insulating covers for copper conductor splices and taps, 8 AWG and smaller.
- Q. Use conductors rated 90 degrees C, inside a ballast compartment or within 6 inches of any ballast.
- R. Conductor Sizes #8 and Larger: Class B stranding.
- S. Install Drop Cords to building structure at locations indicated on Drawings as indicated on Drawings.
- T. The sharing of neutral conductors for multiwire branch circuits is prohibited. All branch circuits shall contain individual neutral conductors.

3.4 INSTALLATION – BUSWAYS

- A. Horizontal runs of busway shall be UL listed for hanging on 10-foot centers in any position. Vertical riser runs of busway shall be supported with rigid and/or spring hangers. (Max. 16 ft. centers).
- B. Final field measurements shall be made by the contractor prior to release for manufacture to assure coordination with other trades. Contractor shall coordinate routing of busways with field conditions.
- C. Contractor shall provide all necessary mounting hardware as recommended by the manufacturer. Utilize trapeze hangers, spring isolators, and ½ inch all-thread on 10-foot centers. Installation shall comply with local seismic zone requirements.
 - 1. Provide approved manufacturer's standard clamps, hangers, brackets, splice plates, reducer plates, blind ends, expansion joints and connectors. Obtain busway components from a single manufacturer.
- D. Engraved nameplates: ½ inch high black letters on yellow laminated plastic nameplate, engraved with the following wording: WARNING! DO NOT USE BUSWAY AS WALKWAY, LADDER OR SUPPORT.

3.5 CONSTRUCTION

- A. Interface with Other Work:
 - 1. Identify wire and cable using Thomas and Betts type WM vinyl markers.
 - 2. Identify each conductor with its circuit number or other designation indicated on Drawings in all junction, pull, terminal boxes and cabinets. Identify neutrals with common circuit numbers in all junction, pull and terminal boxes, panels and cabinets.

3.6 WIRING COLOR CODE

- A. Comply with the following color code for each voltage system.
- B. 208Y/120 Volt System:
 - 1. Phase A - Black.
 - 2. Phase A Switch Leg - Black with "S" tag.
 - 3. Phase B - Red.
 - 4. Phase B Switch Leg - Red with "S" tag.
 - 5. Phase C - Blue.
 - 6. Phase C - Switch Leg - Blue with "S" tag.
 - 7. Travelers - Yellow.
 - 8. Neutral - White.
 - 9. Equipment Ground - Green.
- C. 240/120 Volt System:
 - 1. Phase A - Black.
 - 2. Phase A Switch Leg - Black with "S" tag.
 - 3. Phase B - Orange (High-Leg).
 - 4. Phase C - Blue.
 - 5. Phase C Switch Leg - Blue with "S" tag.
 - 6. Travelers - Yellow.
 - 7. Neutral - White.
 - 8. Equipment Ground - Green.
- D. 480Y/277 Volt System:
 - 1. Phase A - Brown.
 - 2. Phase A Switch Leg - Brown with "S" Tag.
 - 3. Phase B - Orange.

4. Phase B Switch Leg - Orange with "S" Tag.
 5. Phase C - Yellow.
 6. Phase C Switch -Leg- Yellow with "S" Tag.
 7. Travelers - Yellow with "T" Tag.
 8. Neutral - Grey.
 9. Equipment Ground - Green with Yellow stripe.
- E. Use same color for same phase throughout. Use same colors for switch legs. Travelers shall be yellow. Phase rotation shall be same in all panels. Identify large cables with colored tape.
- F. Provide identification tags on each conductor entering panel, switch, junction box and pull box to identify conductor.

3.7 FIELD QUALITY CONTROL

- A. As specified in Section 260500 – Common Work Results for Electrical.
- B. Cables, 600 Volt or less and size no. 3 or larger, shall be meggered using an industry-approved “megger with a minimum of 500 Volt internal generating voltage. All inspection, cleaning and testing procedures shall be in compliance with the recommendations and standards outlined in the “maintenance testing specifications for electrical power distribution equipment and systems”, latest edition, published by International Electrical Testing Association (NETA). Insulation resistance test values shall be no less than 250 megohms. A typewritten report of all readings shall be prepared and submitted.

END OF SECTION

USPS MPF Specification Last Revised: 10/1/2022

SECTION 260533

RACEWAY AND BOXES FOR ELECTRICAL SYSTEMS

PART 1 - GENERAL

1.1 SUMMARY

A. Section Includes:

1. Metal conduit.
2. Flexible metal conduit.
3. Liquidtight metal conduit.
4. Electrical metallic tubing.
5. Fittings and conduit bodies.
6. Wall and ceiling outlet boxes.
7. Pull and junction boxes.
8. Cable trays.
9. Floor boxes with covers (other uses.)

- B. Related Documents: The Contract Documents, as defined in Section 011000 - Summary of Work, apply to the Work of this Section. Additional requirements and information necessary to complete the Work of this Section may be found in other documents.

C. Related Sections:

1. Section 260500 – Common Work Results for Electrical.
2. Section 262726 – Wiring Devices.
3. Section 312000 - Earth Moving.
4. Section 312300 - Excavation and Fill.

1.2 REFERENCES

A. American Society for Testing and Materials (ASTM):

1. ASTM A 123 - Specification for Zinc (Hot-Galvanized) Coatings on Iron and Steel Products.

B. American National Standards Institute (ANSI):

1. ANSI C80.1 - Rigid Steel Conduit, Zinc Coated.
2. ANSI C80.3 - Electrical Metallic Tubing, Zinc Coated.
3. ANSI C80.5 - Rigid Aluminum Conduit.

C. National Electrical Contractors Association (NECA):

1. NECA "Standard of Installation."

D. National Electrical Manufacturers Association (NEMA):

1. NEMA FB 1 - Fittings, Cast Metal Boxes, and Conduit Bodies for Conduit and Cable Assemblies.
2. NEMA RN 1 - Polyvinyl Chloride (PVC) Externally Coated Galvanized Rigid Steel Conduit and Intermediate Metal Conduit.
3. NEMA TC 2 - Electrical Plastic Tubing (EPT) and Conduit (EPC-40 and EPC-80).
4. NEMA TC 3 - PVC Fittings for Use with Rigid PVC Conduit and Tubing.
5. NEMA VE 1 - Metallic Cable Tray Systems.

E. National Fire Protection Association (NFPA):

1. NFPA 70 - National Electrical Code.

1.3 SYSTEM DESCRIPTION

- A. Design Requirements
 - 1. Conduit Size: NFPA 70, unless indicated otherwise on Drawings.

1.4 QUALITY ASSURANCE

- A. Regulatory Requirements:
 - 1. Conform to requirements of NFPA 70.
 - 2. Provide products listed and classified by Underwriters Laboratories, Incorporated.

1.5 PROJECT OR SITE CONDITIONS

- A. Existing Utilities: Contact local utility companies and make arrangements to obtain utility company location and marking service prior to start of Work.
 - 1. Locate existing underground utilities in areas of Work using "Ground Penetrating Radar (GPR)" detection. If utilities are to remain in place, provide means of support and protection during trenching and excavation operations.
 - a. Pothe and locate existing underground utilities at locations to assure that no conflict with Work of this Contract will occur and required clearance is available to prevent damage to existing utilities.
 - b. Perform potholing minimum 10 days before start of excavation or underground work.
 - 2. Should uncharted, or incorrectly charted, piping or other utilities be encountered during excavation, consult utility company and Contracting Officer immediately for directions.
 - 3. Coordinate with Contracting Officer and utility companies to keep existing utility services and facilities in operation.
 - 4. Repair damaged utilities to satisfaction of utility company, at no additional cost to U.S. Postal Service.
 - 5. Do not interrupt existing utilities serving facilities occupied and used by U.S. Postal Service or others, during occupied hours, except when permitted in writing by Contracting Officer and then only after acceptable temporary utility services have been provided and approved by Contracting Officer.

1.6 DELIVERY, STORAGE, AND HANDLING

- A. Section 016000 - Product Requirements: Transport, handle, store, and protect products.
- B. Accept conduit on site. Contractor inspect for damage prior to acceptance.
- C. Protect conduit from corrosion and entrance of debris by storing above grade. Provide appropriate covering.
- D. Protect PVC conduit from sunlight.

PART 2 - PRODUCTS

2.1 CONDUIT REQUIREMENTS

- A. Where conduit is required by standards, codes, or required elsewhere, minimum size shall be as follows:

1. 1/2 inch for power and branch circuit wiring, unless indicated otherwise. All homerun conduits shall be 3/4 inch, minimum.
2. 3/4 inch for communications cable, unless indicated otherwise.
3. 3/4 inch for low voltage, control, intercom, security and communications unless indicated otherwise.
4. Underground conduits shall be sized 1 inch, minimum.

2.2 METAL CONDUIT

- A. Manufacturers: Subject to compliance with project requirements, manufacturers offering specified items which may be incorporated in the Work include the following:
1. Allied Tube & Conduit, Harvey, IL (800) 882-5543.
 2. Wheatland Tube Co., Collinswood, NJ (800) 257-8182.
 3. Republic Wire & Cable, Rocky Mount, NC (800) 533-8198.
 4. Section 016000 - Product Requirements: Product options and substitutions. Substitutions: Permitted.
- B. Rigid Galvanized Steel Conduit (GRC): ANSI C80.1, UL6.
- C. Intermediate Metal Conduit (IMC): UL1242.
- D. Fittings and Conduit Bodies: NEMA FB1 Material to match conduit.

2.3 FLEXIBLE METAL CONDUIT (FMC)

- A. Manufacturers: Subject to compliance with project requirements, manufacturers offering specified items which may be incorporated in the Work include the following:
1. Hubbell, Millford, CT (203) 882-4800.
 2. Electriflex, Roselle, IL (800) 323-6174.
 3. 0-Z/Gedney, Farmington, CT (860) 677-5541.
 4. Section 016000 - Product Requirements: Product options and substitutions. Substitutions: Permitted.
- B. Description: Interlocked steel and aluminum construction.
- C. Fittings: NEMA FB 1.

2.4 LIQUID-TIGHT FLEXIBLE METAL CONDUIT

- A. Manufacturers: Subject to compliance with project requirements, manufacturers offering specified items which may be incorporated in the Work include the following:
1. Hubbell, Millford, CT (203) 882-4800.
 2. Electriflex, Roselle, IL (800) 323-6174.
 3. Anixter, Inc., Skokie, IL (800) ANIXTER.
 4. Section 016000 - Product Requirements: Product options and substitutions. Substitutions: Permitted.
- B. Description: Interlocked steel and aluminum construction with PVC jacket.
- C. Fittings: NEMA FB 1.

2.5 ELECTRICAL METALLIC TUBING (EMT)

- A. Manufacturers: Subject to compliance with project requirements, manufacturers offering specified items which may be incorporated in the Work include the following:
 - 1. Allied Tube & Conduit, Harvey, IL (800) 882-5543.
 - 2. Wheatland Tube Co., Collinswood, NJ (800) 257-8182.
 - 3. Republic Wire & Cable, Rocky Mount, NC (800) 533-8198.
 - 4. Section 016000 - Product Requirements: Product options and substitutions. Substitutions: Permitted.
- B. Description: ANSI C80.3; galvanized tubing.
- C. Fittings and Conduit Bodies: NEMA FB 1; steel set-screw type. Die-cut Zinc not permitted.

2.6 NONMETALLIC CONDUIT

- A. Manufacturers: Subject to compliance with project requirements, manufacturers offering specified items which may be incorporated in the Work include the following:
 - 1. Carlon, Cleveland, OH (800) 322-7566.
 - 2. Section 016000 - Product Requirements: Product options and substitutions. Substitutions: Permitted.
- B. Description: NEMA TC 2; Schedule 40 PVC.
- C. Fittings and Conduit Bodies: NEMA TC 3.

2.7 FITTINGS

- A. Manufacturer: Raco, Inc., South Bend, IN (219) 234-7151.
 - 1. Subject to compliance with project requirements, one of the following manufacturers may also be provided:
 - a. Steel City.
 - b. O-Z/Gedney.
 - 2. Section 016000 - Product Requirements: Product options and substitutions. Substitutions: Permitted.
- B. Conduits 1/2 inch thru 1 inch enter junction boxes, pull boxes, panels, cabinets, and gutters, provide the following:
 - 1. Rigid Conduit: Raco 1222, 1223, 1224.
 - 2. Flexible Metal Conduit: Raco 3302, 3303, 3304, 3305, 3306, 3308.
 - 3. Liquidtight Flexible Metal Conduit: Raco 3511, 3512, 3513, 3541, 3542, 3543.
- C. Conduits 1-1/4 inch and larger entering junction boxes, pull boxes, panels, cabinets, and gutters, provide Insulated throat type bushings; Raco 1225, 1226, 1228, 1230, 1232, 1234, 1236.
- D. Provide threaded joint connectors and malleable iron no thread compression box connectors on rigid conduit. Do not provide fittings requiring set screws or indenter type applications including BM connectors.
- E. Provide only steel set-screw couplings and connectors on EMT conduit.

2.8 CONDUIT STRAPS AND HANGERS

- A. Strap Manufacturer: Raco, Inc., South Bend, IN (219) 234-7151
 - 1. Subject to compliance with project requirements, one of the following manufacturers may also be provided:
 - a. Steel City.
 - b. Unistrut.
 - 2. Section 016000 - Product Requirements: Product options and substitutions. Substitutions: Permitted.

- B. Hanger Manufacturer: Steel City/Thomas & Betts, Memphis, TN (800) 888-0211.
 - 1. Subject to compliance with project requirements, one of the following manufacturers may also be provided:
 - a. Unistrut.
 - b. Raco.
 - 2. Section 016000 - Product Requirements: Product options and substitutions. Substitutions: Permitted.

- C. Straps: Two-hole push on stamped steel straps on surface areas such as concrete, masonry, wide flange beams, columns, and wood.
 - 1. Rigid Conduit: Raco 2232, 2233, 2234, 2235, 2336, 2238.
 - 2. Electrical Metallic Tubing: Raco 2092, 2093, 2094.

- D. Hangers: Lay-in pipe hanger.
 - 1. Conduits 1-1/4 Inch and Larger: Steel-City C-149.

- E. Trapeze Hangers for Conduits Grouped Together: Hangers consisting of all thread rods sized as required and Kingdorff channel.
 - 1. Steel City B-909, 1/2 inch x 1-7/8 inch (12 gauge) with single bolt channel pipe straps.
 - 2. Steel City C-105, C-105-AL, or C-106, (no wire permitted for anchoring conduit).

2.9 SEAL-OFF AND EXPANSION FITTINGS

- A. Seal-Off Fitting Manufacturer: Crouse-Hinds, Syracuse, NY (315) 477-5531.
 - 1. Subject to compliance with project requirements, one of the following manufacturers may also be provided:
 - a. Killark.
 - b. Appleton.
 - c. O-Z/Gedney.
 - 2. Section 016000 - Product Requirements: Product options and substitutions. Substitutions: Permitted.

- B. Expansion Fitting Manufacturer: OZ/Gedney, Farmington, CT (860) 677-5541
 - 1. Subject to compliance with project requirements, one of the following manufacturers may also be provided:
 - a. Crouse-Hinds.
 - b. Killark.
 - c. Appleton.
 - 2. Section 016000 - Product Requirements: Product options and substitutions. Substitutions: Permitted.

- C. Provide seal-off fittings where required by governing authority, code, or as indicated on Drawings.
 - 1. Vertical Runs: Crouse-Hinds Type EYS.
 - 2. Horizontal and Vertical Runs: Crouse-Hinds Type EZS.
 - 3. Elbows: Crouse-Hinds Type EYS.
 - 4. Sealing Compound: "Chico X" fiber and "Chico A".

- D. Provide expansion fittings in conduits where indicated on Drawings or where required to pass through expansion joints embedded in concrete.
 - 1. O-Z/Gedney Type AX.

2.10 OUTLET BOXES

- A. Sheet Metal Outlet Boxes: NEMA OS 1, galvanized steel.
 - 1. Luminaire and Equipment Supporting Boxes: Rated for weight of equipment supported; include 1/2 inch male fixture studs where required.
 - 2. Receptacle and Device Boxes - 4 inch square x 2-1/8 inch deep with raised, single gang, plaster ring unless indicated otherwise.
 - 3. Switch Boxes: 2 inch x 4 inch x 2-1/8 inch deep, unless indicated otherwise.
 - 4. Communication Boxes: 4 inch square x 3 inch deep with raised gang plaster ring unless indicated otherwise.
- B. Cast Boxes: NEMA FB 1, Type FD, aluminum. Provide gasketed cover by box manufacturer. Provide threaded hubs.
- C. Wall Plates for Finished Areas: Specified in Section 262726.

2.11 PULL AND JUNCTION BOXES

- A. Sheet Metal Boxes: NEMA OS 1, galvanized steel.

2.12 FLOOR BOXES

- A. Type: Modular, flush-type dual-service units suitable for wiring method used. Provide dual-service units within carpeted areas only.
- B. Compartmentation: Barrier separates power and signal compartments.
- C. Housing Material: Die-cast aluminum, satin-finished.
- D. Power Receptacle: NEMA WD 6, Configuration 5-20R, ivory finish, unless otherwise indicated.
- E. Signal Outlet: Blank cover with brushed cable opening, unless otherwise indicated.

PART 3 - EXECUTION

3.1 EXAMINATION

- A. Section 017300 - Execution: Verification of existing conditions before starting work.
- B. Verification of Existing Conditions: Verify that field measurements, surfaces, substrates and conditions are as required, and ready to receive Work.
 - 1. Verify routing and termination locations of proposed conduit prior to rough-in.
- C. Existing Utilities, Conduits and Piping:

1. Locate the routings of the existing underground utilities, conduits and piping in the areas of the Work prior to the installation of the proposed conduit. Trace the locations of existing underground utilities, conduits, and piping using "Ground Penetrating Radar (GPR)" detection.
 - a. The routings of these existing underground utilities, conduits and piping shall be identified and marked to avoid any trenching conflicts. These routings shall be recorded on the As-Built drawings prepared by the Contractor for future reference.
 2. Existing utilities, conduits and piping that are to remain shall be supported and protected during the trenching process.
- D. Report in writing to the USPS Project Manager prevailing conditions that will adversely affect satisfactory execution of the Work of this Section. Do not proceed with Work until unsatisfactory conditions have been corrected.
- E. By beginning Work, Contractor accepts conditions and assumes responsibility for correcting unsuitable conditions encountered at no additional cost to the United States Postal Service.

3.2 INSTALLATION - RACEWAYS

- A. Install in accordance with the following schedule, unless indicated otherwise on Drawings: Plastic flexible PVC conduit shall not be permitted. Flexible metal conduit shall be permitted for electrical power and security wiring only and not permitted for fire alarm cables.
1. Above suspended ceilings: Galvanized or sherardised thick wall rigid steel (GRC) or electrical metallic tubing (EMT).
 2. Metal stud walls: Galvanized or sherardised thick wall rigid steel (GRC) or electrical metallic tubing (EMT).
 3. Exposed interior areas: Galvanized or sherardised thick wall rigid steel (GRC) or electrical metallic tubing (EMT).
 4. Exposed exterior areas: Galvanized or sherardised thick wall rigid steel (GRC).
 5. Underground or below slab areas: Rigid polyvinyl chloride conduit (PVC-Sched. 40).
- B. Install conduit in accordance with NECA "Standard of Installation."
- C. Install nonmetallic conduit in accordance with manufacturer's instructions. Nonmetallic conduit shall only be used under slabs or direct buried in earth. Conduit penetrations through slab including elbows shall be galvanized rigid conduit.
- D. Conduit routing indicated on Drawings are approximate locations unless dimensioned. Route parallel and perpendicular to building construction for complete wiring system regardless whether exposed or concealed.
- E. Arrange supports to prevent misalignment during wiring installation.
- F. Support conduit using coated steel or malleable iron straps, lay-in adjustable hangers, clevis hangers, and split hangers.
- G. Group related conduits; support using conduit rack. Construct rack using approved steel channel and provide space on each rack for 25 percent additional conduits.
- H. Fasten conduit supports to building structure and surfaces under provisions of this section.
- I. Do not support conduit with wire or perforated pipe straps in any type structure. Remove wire used for temporary supports. Steel tie wire may be used to anchor conduit down to reinforcing rods in concrete encasement only.
- J. Do not attach conduit or boxes to ceiling support wires. Boxes shall be independently supported.

- K. Arrange conduit to maintain headroom and present neat appearance. Maintain required clearance between conduit and piping.
- L. Route all conduit, whether exposed or concealed, parallel and perpendicular to walls, ceilings, building structures, etc.
- M. Maintain 12 inch clearance between conduit and surfaces with temperatures exceeding 104 degrees F.
- N. Cut EMT conduit square using saw or pipe cutter; de-burr cut ends and ream. Bring conduit to shoulder of fittings; fasten securely.
- O. Join nonmetallic conduit using cement as recommended by manufacturer. Wipe nonmetallic conduit dry and clean before joining. Apply full even coat of cement to entire area inserted in fitting. Allow joint to cure for 20 minutes, minimum.
- P. Use conduit hubs or sealing locknuts to fasten conduit to sheet metal boxes in damp and wet locations and to cast boxes. Use Myers hub connectors on all conduit entering top or sides of all junction boxes, pull boxes, wiring gutters, exposed to weather.
- Q. The number of conduit bends per box shall comply with NFPA 70, Article 360. Conduit bends for "SCS" installation shall not exceed two 90 degree bends or exceed a total of 180 degrees of bend between pull boxes or conduit ends. Pull boxes shall be sized per NEC codes per conduit installed. Use conduit bodies to make sharp changes in direction, as around beams. Use hydraulic one-shot bender to fabricate or use factory elbows for bends in metal conduit larger than 2 inch size.
- R. Avoid moisture traps; provide junction box with drain fitting at low points in conduit system.
- S. Provide suitable fittings to accommodate expansion and deflection where conduit crosses control and expansion joints.
- T. Provide suitable nylon pull string or #14 AWG steel wire in each conduit excluding sleeves and nipples.
- U. Ground and bond conduit per NFPA 70.
- V. Coat all metallic conduit with "General Electric" RTV silicone sealer where conduit is installed in exterior areas or in contact with concrete or earth.
- W. Conduits shall be sized as indicated on Drawings. Where sizes are not indicated, conduit shall be sized per NFPA 70.
- X. Cap all upturned conduits during construction rough-in to prevent moisture or debris from entering. Pull through each and every conduit a dry swab of sufficient size to remove any and all moisture.
- Y. Maximum length of flexible metal conduit (Greenfield), or flexible liquid-tight shall be 5 feet.
- Z. Assure ground continuity on all branch circuitry conduits with two locknuts, one inside and one outside of all boxes, cabinets and gutters for rigid conduit. One locknut inside of all boxes, cabinets, and gutters for EMT.
- AA. Provide conduit supports as follows:
 - 1. Galvanized rigid thick wall conduit (GRC), intermediate grade rigid conduit (IMC) and electrical metallic conduit (EMT) within three feet of all outlet boxes, junction boxes, cabinets, gutters, or fittings. Horizontally anchored at 10 foot maximum intervals. Other spacings indicated on Drawings.

2. Flexible metal conduit (Greenfield) and liquid-tight flexible metal conduit, within 12 inches of all outlet boxes, junction boxes, cabinets, gutters, or fittings and bends or turns. Horizontally anchored at 4-1/2 foot intervals. 1/2 inch minimum size permitted.

BB. Overhead conduits shall be routed below the roof decking. Raceways shall not be routed between the decking flutes.

3.3 INSTALLATION - BOXES

- A. Install boxes in accordance with NECA "Standard of Installation."
- B. Install in locations as shown on Drawings, and as required for splices, taps, wire pulling, equipment connections and compliance with NFPA 70.
- C. Set wall mounted boxes at elevations to accommodate mounting heights indicated or as required for specific project requirements. Orient boxes to accommodate wiring devices as specified in Section 262726.
- D. Electrical boxes are indicated on Drawings in approximate locations unless dimensioned. Adjust box location up to 10 feet if required to accommodate intended purpose with no additional cost to contract. Coordinate mounting heights and locations of outlets mounted above counters, benches, and backsplashes.
- E. Maintain headroom and present neat mechanical appearance.
- F. Install pull boxes and junction boxes above accessible ceilings and in unfinished areas only. Install pull boxes in freezer and dock area above bottom chord of structural joist. Pullboxes sized in excess of 12 inches shall be equipped with hinged and hasped covers.
- G. Install outlet and junction boxes within inaccessible ceiling areas, no more than 6 inches from ceiling access panel or from removable recessed luminaire.
- H. Locate outlet boxes to allow luminaires positioned as indicated on Drawings.
- I. Align adjacent wall mounted outlet boxes for switches, thermostats, and similar devices.
- J. Locate flush mounted box in masonry wall to require cutting of masonry unit corner only. Coordinate masonry cutting to achieve neat opening. Use approved raised gang covers in masonry and stud walls.
- K. Flush mounted boxes shall not be mounted back-to-back in walls; provide minimum 6 inches separation. Provide minimum 24 inches separation in acoustic rated walls.
- L. Secure flush mounted box to interior wall and partition studs. Accurately position to allow for surface finish thickness. Use approved stamped steel bridges to fasten box between studs.
- M. Install flush mounting box without damaging wall insulation or reducing its effectiveness.
- N. Use approved adjustable steel channel fasteners spanning joist for hung ceiling outlet box.
- O. Provide factory sectioned multi-gang boxes where more than one adjacent device is to be mounted. Sectional boxes shall not be permitted.

3.4 FIELD QUALITY CONTROL

- A. Section 014000 - Quality Requirements: Field inspection.
- B. Inspect conduit installation, types, sizes, fittings and attachment to structure.
- C. Inspect box installation, locations, connection to conduit, and attachment to structure.
- D. Inspect cable tray installation, locations, connection to conduit, and attachment to structure.

3.5 ADJUSTING

- A. Adjust flush-mounting outlets to make front flush with finished wall material.
- B. Install knockout closures in unused box openings.

3.6 CLEANING

- A. Clean interior of boxes to remove dust, debris, and other material.
- B. Clean exposed surfaces and restore finish like new.

END OF SECTION

USPS MPF Specification Last Revised: 10/1/2023

SECTION 260623

LIGHTING CONTROL DEVICES

PART 1 - GENERAL

1.1 SUMMARY

- A. Section Includes:
 - 1. Lighting control system for Workroom and VMF building..
 - 2. Control of Interior/Exterior Lighting.
 - 3. Occupancy Photo sensors
- B. Related Documents: The Contract Documents, as defined in Section 011000 - Summary of Work, apply to the work of this section. Additional requirements and information necessary to complete the work of this section may be found in other documents.
- C. Related Sections:
 - 1. Section 019113 - General Commissioning Requirements.
 - 2. Section 260500 - Common Work Results for Electrical.
 - 3. Section 260800 - Commissioning of Electrical Systems.

1.2 REFERENCES

- A. National Electrical Manufacturers Association (NEMA):
 - 1. NEMA ICS 1 - General Standards for Industrial Control and Systems.
- B. National Fire Protection Association (NFPA):
 - 1. NFPA 70 - National Electrical Code.
 - 2. NFPA 101 - Life Safety Code
- C. Codes and Standards:
 - 1. International Building Code / National Electrical Code.
 - 2. Occupational Safety and Health Agency Standards.
 - 3. Illuminating Engineering Society Handbook.
 - 4. ASHRAE Standard 90.1.
 - 5. The International Energy Conservation Code.
- D. U.L. Standards:
 - 1. UL 916 Energy Management Equipment.

1.3 SUBMITTALS

- A. As specified in Section 260500 – Common Work Results for Electrical.
 - 1. Product Data: Data for each component of the lighting control system indicating electrical characteristics and connection requirements.
 - a. Lighting Control Components.
 - b. Digital Interval Timer.
 - c. Digital Time Switches.
 - d. Exterior Photo-Sensor.
 - e. Occupancy Sensors.

2. Shop Drawings: Indicate electrical characteristics and connection requirements, including layout of completed assemblies, interconnecting cabling, dimensions, and power requirements.
3. Assurance/Control Submittals:
 - a. Certificates: Manufacturer's certificate that Products and components meet or exceed specified requirements.
 - b. Qualification Documentation: Submit documentation of experience indicating compliance with specified qualification requirements.

- B. Section 017704 - Closeout Procedures and Training: Procedures for closeout submittals.
1. Project Record Documents: Accurately record the actual locations of Products.
 2. Operating Instructions: Document training by furnishing a sign-in sheet with a description on the training provided, instructors name and organization and those who received training. Refer to 017704 1.3, 1.4 and 1.5 for more specific training.

1.4 SYSTEM DESCRIPTION

- A. Each space enclosed by walls or floor-to-ceiling height partitions must be equipped with at least one automatic control device to independently control the general lighting within the space. This control device must automatically de-energize the space lighting within 30 minutes of all occupants leaving the space. Interior lighting for all spaces must utilize automatic occupancy sensors to turn off lighting in all spaces without occupant intervention.
- B. The service bay lighting systems shall be provided to achieve the required light levels for the four lighting groups as shown on the drawings.
1. Ambient Light Group (ALG): This illumination group shall provide 25 footcandles for operational zones Utilize time switch to obtain high output lighting level of 50 footcandles.
 2. Egress Lighting Group (ELG): This is a condition in which power to the facility or the lighting circuitry is interrupted. During these conditions, an average of one footcandle must be maintained along all emergency egress routes in accordance with the National Fire Protection Agency 101 Life Safety code. The column mounted, emergency battery units within the workroom must provide this emergency egress lighting.
- C. The functional characteristic of each luminaire within the workroom and enclosed platform shall be as follows:
1. All luminaires shall be automatically controlled by luminaire mounted occupancy sensors, unless otherwise indicated. The occupancy sensors must be appropriate for the luminaire mounting height within the workroom or platform.
 2. The occupancy sensors shall be luminaire mounted, passive infra-red type and must automatically turn the "ALG" lighting groups off within 20 minutes of the last detected presence within the Workroom.
- D. Exterior lighting shall be energized by photo-sensor(s) and de-energized by time control functions.
1. The control of the exterior and building mounted signs shall operate similar to the exterior lighting control scheme but shall utilize independent time schedules.

1.5 QUALITY ASSURANCE

- A. Single Source: Provide occupancy sensors, photocells, time switches, digital override timer switches, and other lighting control components from a single lighting control system supplier.
- B. Qualifications:

1. Manufacturer: Company specializing in manufacturing Products specified with minimum 5 years documented experience.
2. Installer: Company specializing in performing the Work of this Section with minimum 5 years documented experience.

C. Regulatory Requirements:

1. Conform to requirements of NFPA 70 and NFPA 101.
2. Furnish products listed and classified by Underwriters Laboratories Inc. as suitable for purpose specified and indicated.
3. Comply with NEC, NEMA and FCC Emission requirements for Class A applications.
4. UL Approvals: Lighting control components are to be UL listed under UL 916 Energy Management Equipment.

D. Testing:

1. Component Pretesting: All component and assemblies are to be pretested and burned-in prior to installation.
2. System Checkout: A factory trained technician shall test each component in the system after installation to verify proper operation. Submit check-out memo from factory representative.
3. Functional testing of the lighting control system shall be provided by an independent commissioning authority in accordance with ASHRAE 90.1 - 2010. Refer to Section 260800 - Commissioning of Electrical Systems.

1.6 DELIVERY, STORAGE, AND HANDLING

- A. Section 016000 - Product Requirements: Transport, Handle, Store, and protect products.
- B. Store products in clean, dry area; maintain temperature to NEMA ICS 1 requirements.

PART 2 - PRODUCTS

2.1 MANUFACTURERS

- A. Subject to compliance with project requirements, manufacturers offering products which may be incorporated in the work include the following:
 1. Cooper Controls, Peachtree City, GA (800) 553-3879.
 2. Current Lighting/NX Lighting Controls, Greenville, SC (866) 758-0116.
 3. Encelium Technologies, inc., Philadelphia, PA (267) 286-0336.
 4. General Electric Company, Plainville, CT (800) 626-2000.
 5. Hubbell Building Automation, Inc, Austin, TX (888) 698-3242.
 6. Intermatic, Inc., Spring Grove, IL (815) 675-7000.
 7. Leviton, Little Neck, NY (800) 824-3005.
 8. Lighting Control & Design, Glendale, CA (800) 345-4448.
 9. Lithonia Lighting (Acuity, Sensor Switch), Conyers, GA (770) 922-9000.
 10. Lutron Electronics, Co. Coopersburg, PA (800) 523-9466.
 11. Novitas, Culver City, CA (310) 568-9600.
 12. Tork, Mount Vernon, NY (914) 664-3542.
 13. WattStopper, Santa Clara, CA (800) 879-8585.
- B. Section 016000 - Product Requirements: Product substitutions: Permitted by manufacturers listed in 2.1A

2.2 LOW VOLTAGE-DIGITAL (INTERVAL) TIMER SWITCH

- A. Provide flush mounted, low voltage, digital, countdown timer switch with the following features:
1. The timer switch shall be programmable to turn loads "off" after a preset time interval of (4) hours maximum. Switch shall be equipped with manual "on/off" pushbutton.
 2. Time switch shall be five terminal, completely self-contained control system that replaces a standard toggle switch and shall operate at 24 VAC/VDC/VAC half wave rectified.
 3. Time scroll features shall allow manual overriding of the preset time-out period. Selecting time scroll UP shall allow time-out period to scroll up throughout the timer possibilities to the maximum. Time scroll DN (down) shall allow time-out period to scroll down to minimum.
 4. Optional flash and beep warnings shall notify occupants when the interval countdown reaches one minute. Switch shall have a Liquid Crystal Display that shows the timer's countdown.
 5. Timer switch shall have manual feature for timer reset where pressing the ON/OFF switch for more than 2 seconds resets the timer to the programmed time-out period.
 6. Timer switch shall mount behind a decorator style face plate. The calibration switch for setting time-out, time scroll and warnings shall be concealed to prevent tampering of adjustments and hardware.
 7. Sensor shall have no minimum load requirement and shall be capable of switching all solid-state LED and electronic fluorescent ballast loads at the rating of the power pack.
 8. Switch shall be manufactured by an ISO 9002 certified manufacturing facility and shall have a defect rate of less than 1/3 of 1 percent. Sensors shall have standard five (5) year warranty and shall be UL and CUL listed.
 9. Provide universal voltage, power pack for 24 VDC operating voltage to the timer switch.
 10. Basis of Design: WattStopper TS-400-24.

2.2 DIGITAL TIME SWITCH

- A. Provide 365/7 day, digital time switch with astronomical clock, holiday scheduling and automatic daylight savings time adjustment. Time switch shall have the following features:
1. Provide maximum 2 hour manual override switch and capacitor carry-over (minimum 100 hours).
 2. Switch shall be compatible with all solid-state LED and electronic fluorescent ballast loads rated 20 Amps at 120 or 277 VAC, DPST.
 3. Provide indoor/outdoor plastic enclosure.
 4. Basis of Design:
 - a. Tork/NSI #DG100A Series.
 - b. Intermatic #ET2000 Series.

2.3 DIGITAL MULTI-CHANNEL TIME SWITCH

- A. Provide 365/7 day, multi-channel, programmable, digital time switch with astronomical clock, holiday scheduling and automatic daylight savings time adjustment. Time switch shall have the following features:
1. Provide maximum 2 hour manual override switch and capacitor carry-over (minimum 2 days) with lithium battery back-up for one year.
 2. Switch shall be compatible with all solid-state LED and electronic fluorescent ballast loads rated 20 Amps per channel at 120 or 277 VAC, SPST.
 3. Switch shall contain "LCD" screen for all programming and shall be channel type to accommodate all site lighting circuits shown with at least one spare channel.
 4. Provide indoor metal enclosure.
 5. Basis of Design:
 - a. Tork/NSI #ELC Series.
 - b. Intermatic #ET70000 Series.

2.4 EXTERIOR PHOTOCONTROL SENSOR

- A. Provide weatherproof line voltage photo-sensor for measuring exterior light levels: ON @ 1 to 5 footcandles / OFF @ 3 to 15 footcandles. The photo-sensor shall be mounted facing north as indicated on the plans. The photo-sensor shall be rated as follows: 1800 Watts @ 120VAC; 4150 Watts @ 277 VAC.
1. Basis of Design:
 - a. Intermatic # K4141C (120/277 VAC).
 - b. Tork/NSI #2001 (1800 Watts @ 120 VAC).
 - c. Tork/NSI #2002 (4620 Watts @ 277 VAC).

2.5 ANALOG, DUAL TECHNOLOGY, SINGLE RELAY, WALL BOX OCCUPANCY SENSOR

- A. Provide flush mounted, single relay, wall box type occupancy sensor with the following features:
1. The Occupancy Sensor Switch shall be a designer-style, multiple-detection technology, universal voltage occupancy sensing wall switch.
 2. Sensor shall be designed to accept and control universal voltage (120VAC to 277VAC, 60Hz.) and rated to control up to 800-watt lighting loads @ 120VAC and 1200 Watts @ 277VAC.
 3. Sensor shall be a two-wire switch capable of handling the following loads:
 - a. Incandescent / Quartz Halogen
 - b. Solid-State LED
 - c. Electronic Low-Voltage
 - d. Magnetic Low-Voltage
 - e. Fluorescent Non-Dimming Ballasts
 4. Sensor shall have a viewing area of not less than one hundred seventy (170°) degrees at an axial distance of 40 feet, 50 feet at 0 degrees, and shall have a total coverage area of not less than 4,000 square feet with an unobstructed view.
 5. Sensor shall utilize non-intrusive, passive dual detection technologies consisting of:
 - a. Passive Infrared (PIR) to read and detect occupants' body heat and movement, and;
 - b. Enhanced microphonics to hear and detect occupancy throughout the entire space.
 6. Under no circumstances shall the unit emit energy of any type into the space that can potentially interfere with electrical, electronic, or medical devices (i.e. hearing aids), etc.
 7. Each unit shall provide manual on/automatic off operation and accept on/off commands from an unlimited number of multi-location 3-way Remotes.
 8. Remote stations shall provide multi-location On / Off control of the switch using conventional 3-way wiring.
 9. The unit shall, when manually turned off by the user, continue to monitor the space, but will not turn on the lights. User shall be able to, at anytime, override this feature by manually turning on the lights.
 10. The unit's operational/parameter programming shall be accomplished with the unit installed and operational without the need to remove the unit (or its faceplate) from its installed location.
 11. Each unit shall provide a LED indicator to provide indication when the sensor detects movement.
 12. Device shall mount in a single gang wall box and be gangable with other designer-style electrical devices and faceplates.
 13. The Sensor shall be UL Listed to U.S. and Canadian standards for 120VAC to 277VAC capacity.
 14. Basis of Design:
 - a. Sensor Switch #WSD-PDT Series.
 - b. WattStopper #PW-100 Series.

2.6 ANALOG DUAL TECHNOLOGY, DUAL RELAY, WALL BOX OCCUPANCY SENSOR

- A. Provide flush mounted, dual relay, wall box type occupancy sensor with the following features:

1. The occupancy sensor switch shall be a designer style, multiple detection technology, universal voltage, occupancy sensing wall switch.
2. Sensor shall be capable of detecting presence in the control area by detecting Doppler shifts in transmitted ultrasound and passive infrared heat changes. Sensor shall utilize Dual Sensing Verification Principal for coordination between ultrasonic and PIR technologies. Each sensing technology shall have a LED indicator that remains active at all times in order to verify detection within the area to be controlled.
3. Sensor shall feature a trigger mode where the end-user can choose which technology will activate the sensor. Selection of technologies for initial, maintain and re-trigger shall be done with DIP switches. Sensor shall have its trigger mode factory preset to allow for quick installation. In this default setting, both technologies must occur in order to initially activate lighting systems. Detection by either technology shall maintain lighting on, and detection by either technology shall turn lights back on after lights were turned off for 5 seconds or less in automatic mode and 30 seconds or less in manual mode.
4. Sensor shall have 4 occupancy logic options for customized control to meet application needs.
5. Ultrasonic sensing shall be volumetric in coverage with a frequency of 40 KHz. It shall utilize Advanced Signal Processing which automatically adjusts the detection threshold dynamically to compensate for constantly changing levels of activity and air flow throughout controlled space.
6. The PIR technology shall utilize a temperature compensated, dual element sensor and a multi-element Fresnel lens. The lens shall offer superior performance in the infrared wavelengths and filter short wavelength IR, such as those emitted by the sun and other visible light sources.
7. Sensor shall utilize SmartSet™ technology to optimize automatic time delay to fit occupancy usage patterns. The use of SmartSet shall be selectable with a DIP switch.
8. Sensor shall utilize Zero Crossing circuitry on both relays to reduce stress on relays and increase sensor life.
9. Sensor shall utilize two relays capable of simultaneously controlling independent lighting loads or circuits. The secondary relay shall be isolated, allowing for two-circuit control.
10. Sensor shall have no minimum load requirement and shall be capable of switching from 0 to 800 Watt solid-state LED; 0 to 800 Watt fluorescent or 1/6 hp at 120 VAC, 60 Hz; and 0 to 1200 Watt fluorescent at 277 VAC, 60 Hz.
11. Sensor shall feature a walk-thru mode, where lights turn off 3 minutes after the area is initially occupied, if no motion is detected after the first 30 seconds, set by a DIP switch.
12. Sensor shall cover up to 1,000 s.f. for walking motion with a field view of 180 degrees and shall have automatic-ON or manual-ON operation for both relays adjustable for each relay.
13. The sensor shall act as a “service switch” to allow operation in the unlikely event of a failure and shall be able to control incandescent, magnetic low voltage, electronic low voltage, “LED” solid state, and fluorescent lighting loads
14. Sensors shall have a built-in light level featuring simple, one-step daylighting setup that works from 8 to 180 footcandles.
15. Wall switch sensor shall be a completely self-contained control unit that replaces a standard toggle switch.
16. To ensure quality and reliability, sensor shall be manufactured by an ISO 9002 certified manufacturing facility and shall have a defect rate of less than 1/3 of 1%. Sensor shall have standard 5-year warranty and shall be UL and CUL listed.
17. Basis of Design: WattStopper #DW-200.

2.7 LUMINAIRE INTEGRATED OCCUPANCY SENSOR

- A. Provide line voltage, low profile, luminaire integrated occupancy sensor with the following features.
 1. Sensor shall be factory or field installed within each luminaire and shall utilize passive infra-red technology to detect presence.
 2. Sensor shall be line voltage rated 0-800 Watts @ 120VAC and 0-1200 Watts @ 277VAC for all solid-state LED and electronic fluorescent lighting loads.

3. Sensor shall be rated for indoor/outdoor installation, shall be UL listed and shall have a standard five (5) year warranty.
4. Sensor shall be available with different lens choices to provide flexibility for varying luminaire mounting heights of 8 ft. to 40 ft. AFF.
5. Sensor shall have adjustable time delay from 30 seconds to 30 minutes; set to 20 minutes.
6. Basis of Design:
 - a. WattStopper #FS-355.
 - b. Leviton #OSFHP Series.

PART 3 - EXECUTION

3.1 EXAMINATION

- A. As specified in Section 260500 – Common Work Results for Electrical.

3.2 INSTALLATION

- A. The Lighting Control System shall be installed and wired completely as shown on the plans by the contractor, who shall make all necessary wiring connections to external devices and equipment.

3.3 FIELD QUALITY CONTROL

- A. As specified in Section 260500 – Common Work Results for Electrical.
- B. Perform operational testing on lighting control system to verify proper operation and field wiring connections.
- C. System Start Up and Commissioning
 1. Manufacturer shall provide a factory authorized technician to confirm proper installation and operation of all lighting control system components.
 2. Lighting control devices shall be tested to ensure that they are calibrated, adjusted, programmed, and in proper working condition in accordance with the construction documents and manufacturer's installation instructions.
 - a. Provide functional performance testing as required by Section 260800 – Commissioning of Electrical Systems.
- D. System Training
 1. Manufacturer shall provide factory authorized technician to train owner personnel in the operation, programming and maintenance of the lighting control system including all occupancy sensors and controls.
- E. System Programming
 1. Manufacturer shall provide system programming including:
 - a. Wiring documentation.
 - b. Switch operation.
 - c. Operating schedules.

END OF SECTION

USPS MPF Specification Last Revised: 10/1/2023

SECTION 262200

SECONDARY DRY-TYPE TRANSFORMERS

PART 1 - GENERAL

1.1 SUMMARY

- A. Work Included: The work specified in this Section includes, but shall not be limited to, the following:
 - 1. Transformers shall be manufactured in compliance with D.O.E. 10 CFR 431.192, April 2013.
 - 2. Transformer shall be UL 1561 listed to feed a mix of equipment load profiles such as inverters without derating or significant degradation of efficiency.
- B. Related Documents: The Contract Documents, as defined in Section 011000 - Summary of Work, apply to the Work of this Section. Additional requirements and information necessary to complete the Work of this Section may be found in other Documents.
- C. Related Sections:
 - 1. Section 260500 - Common Work Results for Electrical.
 - 2. Section 261414 - Infrared Viewing Panels (IR Windows).

1.2 REFERENCES

- A. As specified in Section 260500 – Common Work Results for Electrical.
- B. Institute of Electrical and Electronics Engineers, Inc. (IEEE):
 - 1. IEEE 1100, "IEEE Recommended Practice for Powering and Grounding Electronic Equipment."
 - 2. ANSI/IEEE C57.1110, "Recommended Practice for Establishing Transformer Capability When Feeding Nonsinusoidal Load Currents."
- C. International Code Council (ICC):
 - 1. ICC ES AC156, "Acceptance Criteria for Seismic Qualification by Shake Table Testing of Nonstructural Components and Systems."
 - 2. ICC IBC, "International Building Code."
- D. International Organization for Standardization (ISO):
 - 1. ISO 9001, "Quality Management Systems Requirements."
 - 2. ISO 14001, "Environmental Management Systems Requirements with Guidance for Use."
- E. National Electrical Manufacturers Association (NEMA):
 - 1. NEMA 250, "Enclosures for Electrical Equipment (1000 Volts Maximum)."
 - 2. NEMA ST 20, "Dry Type Transformers for General Applications."
 - 3. NEMA TP 1, "Standard for the Labeling of Distribution Transformer Efficiency."
 - 4. NEMA TP 2, "Standard Test Method for Measuring the Energy Consumption of Distribution Transformers."
- F. National Fire Protection Association (NFPA):
 - 1. NFPA 70, "National Electrical Code," hereinafter referred to as NEC.
 - 2. NFPA 5000, "Building Construction and Safety Code."
- G. Underwriters Laboratories, Inc. (UL):
 - 1. UL 1561, "Standard for Dry Type General Purpose and Power Transformers."

2. UL 250, "Enclosure for Electrical Equipment".

H. 2005 Energy Act PUBLIC LAW 109-58-AUG. 8, 2005. Comply with all Rules from Department of Energy:

1. 10 CFR 429

2. 10 CFR 431

1.3 SUBMITTALS

A. As specified in Section 260500 – Common Work Results for Electrical.

B. Section 013300 - Submittal Procedures: Procedures for submittals.

1. Product Data: Outline and support point dimensions of enclosures and accessories, unit weight, voltage, kVA, and impedance ratings and characteristics, tap configurations, insulation system type, and rated temperature rise.

2. Manufacturer's Test Reports:

a. Copy of ISO 9001 Certification of manufacturing operation.

b. Copy of ISO 14001 Certification of manufacturing operation.

c. Confirmation that transformers are UL 1561 listed with a K1 rating. Those requiring a k factor rating will be K13 rated.

d. Construction details, including, but not limited to, enclosure dimensions, kVA rating, primary and secondary nominal voltages, voltage taps, approximate center of gravity, and unit weight.

e. Basic performance characteristics, including, but not limited to, insulation class, temperature rise, core and coil materials, impedances and audible noise level, unit weight, and inrush value expressed in a multiplier of rated primary current RMS.

f. Efficiency data shall be reported as described in the following sections. Reference temperatures shall be included when reporting efficiency.

1) No load and full load losses shall be calculated per NEMA ST 20 test methods.

2) Efficiency curves as follows:

i. Linear loads.

ii. Data per the non linear load test program.

g. Sound level ratings.

3. Assurance/Control Submittals:

a. Certificates: Manufacturer's certificate that Products meet or exceed specified requirements.

b. Manufacturer's Instructions: Indicate application conditions and limitations of use stipulated by Product testing agency. Include instructions for storage, handling, protection, examination, preparation, installation, and starting of Product.

C. Section 017704 - Closeout Procedures and Training: Procedures for closeout submittals:

1. Project Record Documents: Record actual locations of transformers.

2. Maintenance Data: Include recommended maintenance procedures and intervals.

1.4 QUALITY ASSURANCE

A. As specified in Section 260500 – Common Work Results for Electrical.

B. Regulatory Requirements: Comply with applicable requirements of the laws, codes, ordinances, and regulations of Federal, State, and local authorities having jurisdiction. Obtain necessary approvals from such authorities.

1. Seismic Requirements:

a. ICC IBC, NFPA 5000.

- b. Tri axial shake table test results conducted in accordance with the ICC ES AC156 test protocol 3 (Acceptance Criteria for Seismic Qualification Testing of Nonstructural Components).
 2. Comply with D.O.E. Guidelines established for manufacture, January 1, 2016 (10 CFR 431.192, April 2013).
- C. Compliance: Comply with applicable requirements of the following standards.
 1. CSA 802.2.
 2. CSA C22.2.
 3. ASHRAE 90.1.
- D. The manufacturer of this equipment shall have produced similar electrical equipment for a minimum period of ten (10) years.

1.5 DELIVERY, STORAGE, AND HANDLING

- A. Section 016000 - Product Requirements: Transport, handle, store, and protect Products.
- B. Transformers shall be packaged for shipment using materials that shall have the least environmental impact.
 1. Transformer Wrapping: Transformers shall be protected by cardboard protective material; all plastic wraps shall not be accepted.
 2. Transformer Shipping Base: Transformers shall be shipped on a base that uses at least 50 percent less wood than traditional pallets. Comply with ISPM No. 15.
- C. Store in a warm, dry location with uniform temperature. Cover ventilation openings to keep out dust, water, and other foreign material.
- D. Handle transformers using lifting eyes and/or brackets provided for that purpose. Protect against unfavorable external environment such as rain and snow, during handling.

PART 2 - PRODUCTS

2.1 MANUFACTURERS

- A. Subject to compliance with project requirements, manufacturers offering Products which may be incorporated in the Work include the following:
 1. ABB/G.E. Industrial Solutions (ABB/GEIS), Mebane, NC (800) 431-7867.
 2. Eaton/Cutler-Hammer Corporation, Pittsburgh, PA (800) 525-2000.
 3. Siemens Energy & Automation, Inc., Alpharetta, GA (800) 964-4114.
 4. Square D Company, Palatine, IL (800) 392-8781.
- B. Basis of Design: Product specified shall be D.O.E. 10 CFR 431.192, April 2013 compliant transformers ("EX" Series) as manufactured by Square D Schneider Electric. Items specified are to establish a standard of quality for design, function, materials, and appearance. Equivalent products by other manufacturers are acceptable. The Architect/Engineer will be the sole judge of the basis of what is equivalent.
- C. Section 016000 - Product Requirements: Product options and substitutions. Substitutions: Permitted.

2.2 TWO WINDING TRANSFORMERS

- A. The transformer shall be UL 1561 listed and labeled with a K1 rating (per UL 1561 35.2.1 and 34.2). Provide K13 rated transformers to serve mail processing equipment and other non-linear loads.
- B. Windings shall be continuous wound copper with brazed or welded terminations.
- C. Insulation and varnish systems shall be Nomex-based UL recognized 220 degrees C class utilizing an epoxy polyester impregnation.
- D. Maximum winding temperature rise for K1 rated units shall be 80 degrees C and K13 rated units shall be 115 degrees C rise.
- E. Terminals, including, but not limited to, those for changing taps, shall be readily accessible by removing a front coverplate.
- F. The transformers shall have a basic impulse level of 10 kV BIL.
- G. Voltage taps shall be as follows:
 - 1. Primary 480 volts.
 - a. For transformers 15 kVA to 300 kVA, provide two 2-1/2 percent full capacity taps above and four 2-1/2 percent below nominal primary voltage.
 - b. For transformers 500 kVA to 750 kVA, provide two 2-1/2 percent full capacity taps above and two 2-1/2 percent below nominal primary voltage.
- H. Impedance shall be the manufacturer's standard.
- I. Three phase transformer efficiency shall be as stated below (tested at 35 percent of the nameplate rating, per D.O.E. 10 CFR 431.192):
- J. Sound Levels shall be as follows:
 - 1. 15 and 30 kVA: 39 dB.
 - 2. 45 and 75 kVA: 44 dB.
 - 3. 112.5 kVA: 47 dB.
 - 4. 150 to 225 kVA: 49 dB.
 - 5. 300 kVA: 54 dB.
- K. Transformers shall be designed for continuous operation at rated kVA, for 24 hours a day, 365 days a year operation, with normal life expectancy as defined in ANSI C57.96.
- L. Where required for K13 rating, the neutral bus shall be configured to accommodate 200 percent of the rated current.
- M. Ground core and coil assembly to enclosure by means of a visible flexible copper grounding strap in accordance with Article 250 of NFPA 70.
- N. Mounting: Suitable for wall, floor, or trapeze mounting, except transformers larger than 75 kVA, suitable for floor mounting.

2.3 ENCLOSURE

- A. The enclosure construction shall be ventilated, NEMA 2 drip-proof, with lifting holes. All ventilation openings shall be protected against falling dirt. On outdoor units, provide weather shields over ventilated openings.
- B. Nameplate: Include transformer connection data and overload capacity based on rated allowable temperature rise.

2.4 SOURCE QUALITY CONTROL

- A. Production test each transformer according to NEMA ST20.

PART 3 - EXECUTION

3.1 EXAMINATION

- A. As specified in Section 260500 – Common Work Results for Electrical.

3.2 PREPARATION

- A. Provide minimum 3 inch high concrete pad for floor mounted transformers.

3.3 INSTALLATION

- A. Install transformers in accordance with NECA SI and manufacturer's published instructions, at locations and as indicated on Drawings.
 - 1. Use manufacturer approved mounting brackets for transformers supported from building structure.
 - 2. Securely anchor transformers to concrete pad for floor mounted transformers.
 - 3. Provide working clearances in conformance with NFPA 70 and manufacturer's recommendations.
 - 4. Provide both primary and secondary protection using fuses or circuit breakers as indicated on Drawings.
- B. Set transformers plumb and level.
- C. Use minimum 2 foot length flexible conduit for connections to transformer case. Make conduit connections to side panel of enclosure.
- D. Mount transformers on vibration isolating pads suitable for isolating transformer noise from building structure.
- E. Provide grounding and bonding as specified in Section 260500.
- F. Furnish and install engraved plastic nameplates to include the voltage and source of power upstream, as specified in Section 260500.
- G. Furnish and install seismic restraints designed for type of mounting used.

3.4 FIELD QUALITY CONTROL

- A. As specified in Section 260500 – Common Work Results for Electrical.
- B. Section 014000 - Quality Control: Field testing and inspection.
- C. Check for damage and tight connections prior to energizing transformer.
- D. Measure primary and secondary voltages and make appropriate tap adjustments.

3.5 Transformer Data Sheet

	<u>Secondary Dry Type Transformers</u>		
1.	Manufacture name and model		TBD
2.	Size	<u>kVA</u>	45
3.	Primary Voltage	<u>V</u>	480
4.	Secondary Volatge	<u>V</u>	280
5.	Z%		4%
6.	Primary BIL	<u>KV</u>	10
7.	Secondary BIL	<u>KV</u>	10
8.	<u>Enclosure</u>		
8.1.	Type		NEMA 12
8.2.	Material of enclosure		steel
8.3.	Thickness of enclosure		----
8.4.	Color		ANSI 70 Gray
9.	Steady-State Temperature Rise		80C
10.	Short Circuit Withstand Level	<u>KA</u>	25
11.	Winding material		Copper
12.	Number of phases_		3

END OF SECTION

USPS MPF Specification Last Revised: 10/1/2023

SECTION 262416

PANELBOARDS

PART 1 - GENERAL

1.1 SUMMARY

- A. This section includes:
 - 1. Panelboards.
- B. Related Documents: The contract documents as defined in Section 011000 – Summary of Work, apply to the work of this section. Additional requirements and information necessary to complete the work of this section may be found in other documents.
- C. Related Sections:
 - 1. Section 260500 – Common Work Results for Electrical.

1.2 REFERENCES

- A. As specified in Section 260500 - Common Work Results for Electrical.
- B. National Electrical Manufacturers Association (NEMA):
 - 1. NEMA AB 1 – Molded Case Circuit Breakers.
 - 2. NEMA ICS 2 – Industrial Control Devices, Controllers, and Assemblies.
 - 3. NEMA KS 1 – Enclosed Switches.
 - 4. NEMA PB 1 – Panelboards.
 - 5. NEMA PB 1.1 – Instructions for Safe Installation, Operation and Maintenance of Panelboards Rated 600 Volts or Less.
- C. Underwriters Laboratories (UL):
 - 1. UL 486 – Molded Case Circuit Breakers.
 - 2. UL 67 – Heat Rise Test for Panelboards.
 - 3. UL 50 – Steel Gauge Requirements for Cabinets and Enclosures.
 - 4. UL 1449 4th Edition – Standard for Transient Voltage Surge Suppressors.

1.3 SUBMITTALS

- A. As specified in Section 260500 – Common Work Results for Electrical.
 - 1. Shop Drawings: Indicate outline and support point dimensions, voltage, main bus ampacity, integrated short circuit ampere rating, circuit breaker and fusible switch arrangement and sizes.
 - 2. Manufacturer's Installation Instructions: Indicate application conditions and limitations of use stipulated by Product testing agency. Include instructions for storage, handling, protection, examination, preparation, installation, and starting of Product.
 - 3. Shall include UL 1449 Listing documentation verifying the following:
 - a. Short Circuit Current Rating (SCCR).
 - b. Voltage Protection Ratings (VPRs) for all modes.
 - c. Maximum Continuous Operating Voltage Rating (MCOV).
 - d. I-nominal rating (I-n).

- B. Section 017704 – Closeout Procedures and Training: Procedures for closeout submittals:
 - 1. Project Record Documents: Record actual locations of Products; indicate actual branch circuit arrangement.
 - 2. Operation and Maintenance Data: Include spare parts data listing; source and current prices of replacement parts and supplies; and recommended maintenance procedures and intervals.
 - 3. Submit data showing compliance with UL 1449.

1.4 QUALITY ASSURANCE

- A. As specified in Section 260500 - Common Work Results for Electrical
- B. Panelboards shall be UL Listed and labeled and shall be designed in accordance with the applicable standards of ANSI and NEMA.
- C. Qualifications
 - 1. Manufacturer: Company specializing in manufacturing the Products specified in this section with minimum five years documented experience.

PART 2 - PRODUCTS

2.1 GENERAL CLASSIFICATION

- A. Manufacturers: ABB/G.E. Industrial Solutions (ABB/GEIS) Catalog numbers are used to identify type of equipment specified. Equivalent products by the following manufacturers are acceptable:
 - 1. Siemens
 - 2. Square-D
 - 3. Eaton/Cutler Hammer
 - a. Branch Circuit Panels:
 - 1) 120/208V: ABB/GEIS Type ReliaGear.
 - b. Distribution Panels:
 - 1) Circuit breaker: ABB/GEIS Type ReliaGear nexT.
 - 4. No substitutions permitted.

2.2 BRANCH CIRCUIT PANELS

- A. Cabinet: Construct cabinet with code gauge galvanized steel. Provide minimum 20 inch wide cabinets, and extra wiring space where incoming feed-through or parallel lines are required.
- B. Doors: Provide single door construction, made of cold-rolled steel. Door shall have concealed hinges, flush catch, and lock. (Tee bar handles not acceptable). Secure top and bottom of door to cabinet by slotted steel bolts. Release shall be by one-half turn with a screwdriver. All panels shall be keyed alike.
 - 1. Panelboards shall be equipped with “door within door” type trim.
- C. Panels located adjacent to each other shall have identically sized enclosures and trims.
- D. Finish: Finish exposed parts with one coat of primer and one coat of light gray enamel suitable for overpainting in field if desired.
- E. Phase, neutral and ground bus bars shall be tin plated copper.
- F. Provide all hardware for future breakers, identified on drawings as SPACES, or for the full length of usable bus, whichever is longer.

- G. Provide ground bus with full complement of terminals in addition to insulated neutral bus.
- H. Circuit Breakers:
 - 1. Provide multi-pole units with common trip elements. Handle ties are not acceptable.
 - 2. Provide circuit breakers equipped with padlockable handle attachments, padlocks and keys for padlocking the breaker in the "on" position when used to serve Fire Alarm, Security and CCTV Systems. Handle padlock attachment shall be similar to Square D types #QOHPL or #QO1PA with padlock and keys or Garvin Industries #UBL2-UPC. Key operated, circuit breaker attachments utilizing a screwdriver or allen wrench shall not be acceptable.
 - 3. 120/208V branch circuit panelboards: Molded cast bolt-on type designed for 120/208V, three phase, four wire service with minimum 10,000 amperes rms short circuit rating.
 - 4. 277/480V branch circuit panelboards: Molded cast bolt-on type designed for 277/480V, three phase, four wire service with minimum 14,000 amperes rms short circuit rating.
- I. Main circuit breakers shall be individually mounted. The panelboard interior assembly shall be dead front with panelboard front removed. Main lugs or main breakers shall have barriers on five sides. The barrier in front of the main lugs shall be hinged to a fixed part of the interior. The end of the bus structure opposite the main shall have barriers.
- J. Provide all panelboards with lockout/tagout devices; Circuit-Safe type as manufactured by Stranco, Inc. or approved equal.
- K. Nameplates: Provide engraved plastic nameplate identification on outside of each panel to include the voltage and source of power upstream, as specified in section 260500.
- L. Circuit directories: Provide a metal-framed circuit directory on inside of inner door, with plastic protector.
- M. Provide two 3/4 inch and one 1 inch spare empty conduits routed above into accessible ceiling space from all flush mounted panelboards.
- N. Panels serving electronic equipment and/or other harmonic producing loads shall be equipped with double neutral bus bars.

PART 3 - EXECUTION

3.1 EXAMINATION

- A. As specified in Section 260500 – Common Work Results for Electrical.

3.2 CLEARANCES

- A. Minimum code required clearances around panelboards must be maintained.

3.3 INSTALLATION

- A. Install panelboards in accordance with NEMA PB 1.1.
- B. Install panelboards plumb. Provide supports in accordance with Section 260500.
- C. Provide filler plates for unused spaces in panelboards.

3.4 MOUNTING HEIGHT

- A. Typically mount panel boards top at 6 feet above finished floor but no more than 6 feet 6 inches above finished floor to top of circuit breaker handle.

3.5 MOUNTING HARDWARE

- A. Provide all necessary blocking, channels and other hardware for securing panelboards to wall, column, or other parts of building structure.

3.6 FIELD CONTROL

- A. Section 014000 – Quality Requirements: Field Testing and Inspection.
- B. Perform inspections and tests listed in NETA ATS, Section 7.6.
- C. Measure steady state load currents at each panelboard feeder; rearrange circuits in the panelboard to balance the phase loads to within 20 percent of each other. Maintain proper phasing for multi-wire branch circuits.
- D. Inspect for physical damage, proper alignment, anchorage, and grounding. Check proper installation and tightness of connections for circuit breakers.

END OF SECTION

USPS MPF Specification Last Revised: 10/1/2022

SECTION 262726

WIRING DEVICES

PART 1 - GENERAL

1.1 SUMMARY

- A. Section Includes:
 - 1. Wall switches.
 - 2. Receptacles.
 - 3. Device plates and box covers.
 - 4. Digital Interval Countdown Timer Switch
- B. Related Documents: The Contract Documents, as defined in Section 011000 - Summary of Work, apply to the Work of this Section. Additional requirements and information necessary to complete the Work of this Section may be found in other documents.
- C. Related Sections:
 - 1. Section 260500 - Common Work Results for Electrical.

1.2 REFERENCES

- A. National Electrical Contractors Association (NECA):
 - 1. NECA "Standard of Installation."
- B. National Electrical Manufacturers Association (NEMA):
 - 1. NEMA WD 1 – General Requirements for Wiring Devices.
 - 2. NEMA WD 6 – Wiring Devices – Dimensional Requirements.
- C. National Fire Protection Association (NFPA):
 - 1. NFPA 70 - National Electrical Code.

1.3 QUALITY ASSURANCE

- A. Qualifications:
 - 1. Manufacturer: Company specializing in manufacturing the Products specified in this section with minimum 5 years documented experience.
- B. Regulatory Requirements:
 - 1. Conform to requirements of NFPA 70.
 - 2. Provide Products listed and classified by Underwriters Laboratories, Incorporated.

1.4 SUBMITTALS

- A. Product data required.

PART 2 - PRODUCTS

2.1 WALL SWITCHES

- A. Manufacturers: Subject to compliance with project requirements, manufacturers offering specified items which may be incorporated in the Work include the following:
1. Hubbell, Inc, Milford, CT (203) 882-4800.
 2. Leviton Manufacturing, Company, Inc., Little Neck, NY (800) 824-3005.
 3. Pass & Seymour, Syracuse, NY (800) 776-4035.
- B. Section 016000 - Product Requirements: Product options and substitutions. Substitutions: Permitted.
- C. Provide 20Amp, 120/277Volt, specification grade, flush single pole toggle switches with side and back wired screw terminals. All switches shall be equipped with grounding screws.
- D. Single Pole Switch:
1. Leviton Cat. No.1221-2.
 2. P&S Cat. No. PS20AC1I.
 3. Hubbell Cat. No. HBL1221.
- E. Double Pole Switch:
1. Leviton Cat. No. 1222-2.
 2. P&S Cat. No. PS20AC2.
 3. Hubbell, Cat. No. HBL1222.
- F. Three-way Switch:
1. Leviton, Cat. No. 1223-2.
 2. P&S Cat. No. PS20AC-3.
 3. Hubbell Cat. No. HBL1223.
- G. Indicator Switch:
1. Leviton Cat. No. 1221-PLR (Red).
 2. P&S Cat. No. PS20AC1-RPL (Red).
 3. Hubbell Cat. No. HBL1221PL (Red).
- H. Locator Switch:
1. Leviton Cat. No. 1221-LHC (Clear).
 2. P&S Cat. No. PS20AC1-CSL (Clear).
 3. Hubbell Cat. No. HBL1221IL (Clear).
- I. Locking Switch:
1. Leviton Cat. No. 1221-2L.
 2. P&S Cat. No. PS20AC1-L.
 3. Hubbell Cat. No. HBL1221L.
- J. Color: Switches located within the Retail Area to be mounted in "blue" or "red" painted walls shall be black. All other switches shall be white unless indicated otherwise.

2.2 RECEPTACLES

- A. Manufacturers: Subject to compliance with project requirements, manufacturers offering specified items which may be incorporated in the Work include the following:
1. Leviton Manufacturing, Company, Inc., Little Neck, NY (800) 824-3005.
 2. Pass & Seymour, Syracuse, NY (800) 776-4035.
 3. Hubbell, Inc, Milford, CT (203) 882-4800.

4. Section 016000 - Product Requirements: Product options and substitutions. Substitutions: Permitted.
- B. Provide duplex, specification grade, 20Amp, 125Volt, 2 pole, 3 wire receptacles with grounding screw.
- C. Duplex Convenience Receptacle:
 1. Leviton Cat. No. 5362.
 2. P&S Cat. No. 5362.
 3. Hubbell Cat. No. HBL5352.
- D. Tamper and Weather Resistant GFCI Receptacle (Side Wired Feed-Thru):
 1. Hubbell Cat. No. GFR5362SG.
- E. Color: Receptacles located within the Retail Area to be mounted in "blue" or "red" painted walls shall be black. All other receptacles shall be white unless indicated otherwise.

2.3 WALL PLATES

- A. Manufacturers: Subject to compliance with project requirements, manufacturers offering specified items which may be incorporated in the Work include the following:
 1. P&S Sierra.
 2. Hubbell.
 3. Leviton.
 4. Section 016000 - Product Requirements: Product options and substitutions. Substitutions: Permitted.
- B. Coverplate: Coverplates to be installed within the Retail Areas on "blue" or "red" painted walls shall be black smooth thermoplastic. All other coverplates shall be white smooth thermoplastic unless otherwise noted.
 1. Sierra TP8-W.
- C. Weatherproof Coverplate: Gasketed cast metal with hinged gasketed device.
 1. Sierra 4510 cast aluminum.
- D. Integral locking and pad-lockable coverplates:
 1. Duplex receptacles shall be equipped with Decora style, stainless steel, single gang, locking coverplates: Pass & Seymour/Legrand #WR26L.
 2. Quadraplex receptacles shall be equipped die-cast metal, low profile, two gang, flip type, pad-lockable coverplates: Hubbell/TayMac #MX2050S.
 - a. Provide two (2) keyed, padlocks for each quadraplex coverplate: Master Lock #4120KA.
 - b. All quadraplex receptacles to be keyed alike.

PART 3 - EXECUTION

3.1 EXAMINATION

- A. Section 017300 - Execution: Verification of existing conditions before starting work.
- B. Verification of Conditions: Verify that field measurements, surfaces, substrates and conditions are as required, and ready to receive Work.
 1. Verify that outlet boxes are installed at proper height.
 2. Verify that wall openings are neatly cut and will be completely covered by wall plates.
 3. Verify that branch circuit wiring installation is completed, tested, and ready for connection to wiring devices.

3.2 PREPARATION

- A. Provide extension rings to bring outlet boxes flush with finished surface.
- B. Clean debris from outlet boxes.

3.3 INSTALLATION

- A. Install wiring devices as indicated, in accordance with manufacturer's written instruction, applicable requirements of the NEC and NECA "Standard of Installation", and in accordance with recognized industry practices to fulfill project requirements.
- B. Install devices plumb and level.
- C. Install switches with OFF position down.
- D. Install receptacles with grounding pole on bottom.
- E. Connect wiring device grounding terminal to branch circuit equipment grounding conductor.
- F. Connect wiring devices by wrapping conductor 2/3 of screw diameter in clockwise direction around screw terminal. Tighten screw to 12 pound-inches. Do not use spring pressure devices for wire connections.
- G. Install galvanized steel plates on outlet boxes and junction boxes in unfinished areas, above accessible ceilings, and on surface mounted outlets.
- H. Provide coverplates on switch, receptacle, and blank outlets.
- I. Receptacles mounted within 8 feet of a fire extinguisher shall be equipped with integral locking or pad-lockable coverplates as specified in paragraph 2.3 D.

3.4 LABELING

- A. All coverplates for receptacles and switches shall be labeled with the branch circuit number. Label shall be machine generated and permanently affixed to the outside of the coverplate.

3.5 CONSTRUCTION

- A. Interface with other work:
 - 1. Coordinate locations of outlet boxes provided under Section 260533 to obtain mounting heights indicated on Drawings.

3.6 FIELD QUALITY CONTROL

- A. Section 014000 - Quality Requirements: Field inspection.
- B. Prior to energizing circuitry, test wiring for electrical continuity, and for short circuits. Ensure proper polarity of connections is maintained. Subsequent to energization, test wiring devices to demonstrate compliance with requirements.
- C. Inspect each wiring device for defects.

- D. Operate each wall switch with circuit energized and verify proper operation.
- E. Verify that each receptacle device is energized.
- F. Test each receptacle device for proper polarity.
- G. Test each GFCI receptacle device for proper operation.

3.7 ADJUSTING

- A. Adjust devices and wall plates to be flush, level and plumb with wall.

3.8 CLEANING

- A. Section 017300 - Execution: Cleaning installed work.
- B. Clean exposed surfaces to remove splatters and restore finish.

END OF SECTION

USPS MPF Specification Last Revised: 10/1/2022

SECTION 262816

ENCLOSED SWITCHES AND CIRCUIT BREAKERS

PART 1 - GENERAL

1.1 SUMMARY

- A. Section Includes:
 - 1. Fusible switches.
 - 2. Nonfusible switches.
 - 3. Fuses.
 - 4. Circuit breakers
- B. Related Documents: The Contract Documents, as defined in Section 011000 - Summary of Work, apply to the Work of this Section. Additional requirements and information necessary to complete the Work of this Section may be found in other Documents.
- C. Related Sections:
 - 1. Section 260500 - Common Work Results for Electrical: Basic electrical methods.

1.2 REFERENCES

- A. National Electrical Testing Association (NETA):
 - 1. NETA ATS - Acceptance Testing Specifications for Electrical Power Distribution Equipment and Systems.
- B. National Electrical Contractors Association (NECA):
 - 1. NECA SI - Standard of Installation.
- C. National Electrical Manufacturers Association (NEMA):
 - 1. NEMA FU 1 - Low Voltage Cartridge Fuses.
 - 2. NEMA KS 1 - Enclosed Switches.
- D. National Fire Protection Association (NFPA):
 - 1. NFPA 70 - National Electrical Code.

1.3 SUBMITTALS

- A. Section 013300 - Submittal Procedures: Procedures for submittals.
 - 1. Product Data:
 - a. Switch ratings and enclosure dimensions.
 - b. Fuse data sheets showing electrical characteristics including time-current curves.
 - c. Circuit Breaker data sheets showing electrical characteristics including time-current curves.
 - 2. Assurance/Control Submittals:
 - a. Certificates: Manufacturer's certificate that Products meet or exceed specified requirements.
 - b. Manufacturer's Instructions: Indicate application conditions and limitations of use stipulated by Product testing agency. Include instructions for storage, handling, protection, examination, preparation, installation, and starting of Product.

- B. Section 017704 - Closeout Procedures and Training: Procedures for closeout submittals.
 - 1. Project Record Documents: Record actual locations of enclosed switches and actual fuse and breaker sizes.

1.4 QUALITY ASSURANCE

- A. Perform Work in accordance with NECA SI.
- B. Manufacturer Qualifications: Company specializing in manufacturing Products specified in this Section with minimum five years documented experience.
- C. Regulatory Requirements:
 - 1. Conform to requirements of NFPA 70.
 - 2. Products: Listed and classified by Underwriters Laboratories, Incorporated as suitable for purpose specified and indicated.

1.5 MAINTENANCE

- A. Section 017704 - Closeout Procedures and Training: Procedures for closeout submittals.
- B. Extra Products: At completion of installation, deliver to USPS Project Manager.
 - 1. Three of each size and type fuse installed.

PART 2 - PRODUCTS

2.1 MANUFACTURERS

- A. Switches: Subject to compliance with project requirements, manufacturer's offering Products which may be incorporated in the Work include the following:
 - 1. ABB/G.E. Industrial Solutions (ABB/GEIS), Mebane, NC (800) 431-7867.
 - 2. Siemens Energy & Automation, Alpharetta, GA (800) 964-4114.
 - 3. Square D Company, Palatine, IL (800) 392-8781.
 - 4. Eaton/Cutler Hammer Corporation, Pittsburg, PA (800) 525-2000.
- B. Fuses: Subject to compliance with project requirements, manufacturers offering Products which may be incorporated in the Work include the following:
 - 1. Cooper Industries Incorporated, Waukesha, WI (414) 524-3300.
 - 2. Littlefuse Inc., Chicago, IL (773) 628-1000.
 - 3. Gould Shawmut, Newburyport, MA (508) 462-6662.
- C. Circuit Breakers: Subject to compliance with project requirements, manufacturers offering Products which may be incorporated in the Work include the following:
 - 1. General Electric Company (800) 626-2000.
 - 2. Siemens Energy & Automation, Alpharetta, GA (800) 964-4114.
 - 3. Square D Company, Palatine, IL (800) 392-8781.
 - 4. Eaton Corporation, Cutler-Hammer Products, Pittsburg, PA (800) 525-2000.
- D. Section 016000 - Product Requirements: Product options and substitutions. Substitutions not permitted.

2.2 FUSIBLE ENCLOSED SWITCH ASSEMBLIES

- A. NEMA KS 1, Type HD heavy duty, 100,000 AIC load interrupter enclosed knife switch with externally operable handle interlocked to prevent opening front cover with switch in ON position. Cover shall be equipped with a manual defeat to allow opening while energized by authorized personnel. Handle shall be lockable in ON or OFF position.
- B. Rating: 250 volts AC or 600 volts AC as indicated on Drawings.
- C. Fuse Clips: Designed to accommodate Class R fuses.
- D. Enclosures: NEMA KS 1.
 - 1. Interior Dry Locations: NEMA Type 1 or 12.
 - 2. Exterior Locations: NEMA Type 3R.
- E. Provide factory ground lug and neutral block if required.

2.3 NONFUSIBLE SWITCH ASSEMBLIES

- A. NEMA KS 1, Type GD General Duty, load interrupter enclosed knife switch with externally operable handle interlocked to prevent opening front cover with switch in ON position. Cover shall be equipped with a manual defeat to allow opening while energized by authorized personnel. Handle shall be lockable in ON or OFF position.
- B. Rating: 250 volts AC or 600 volts AC as indicated on Drawings.
- C. Enclosures: NEMA KS 1.
 - 1. Interior Dry Locations: NEMA Type 1 or 12.
 - 2. Exterior Locations: NEMA Type 3R .
- D. Provide factory ground lug and neutral block if required.

2.4 FUSES

- A. NEMA FU 1, Class RK1, dual element, current limiting, time delay, 250 volt AC or 600 volt AC as indicated on drawings.
- B. Interrupting Rating: 100,000 rms amperes.

2.5 Circuit Breakers

- A. NEMA 1 , Class [] , 120/208V and 277/480V AC, Wire size range: #12-4/0 , Amp ratings : as indicated on drawings
- B. Interrupting Rating: 10kA-22kA

PART 3 - EXECUTION

3.1 EXAMINATION

- A. As specified in Section 260500 - Common Work Results for Electrical.

3.2 INSTALLATION

A. Switches:

1. Install in accordance with manufacturers published instructions and NECA SI.
2. Install where indicated on Drawings, where required by equipment, and where required by NFPA 70.
3. Apply adhesive tag on inside door of each fused switch indicating NEMA fuse class and size installed.
4. Furnish and install engraved plastic nameplates to include the voltage and source of power upstream, as specified in section 260500.

B. Fuses:

1. Install fuses in fusible switches in accordance with manufacturer's published instructions, as indicated on Drawings, or as required by loading per NFPA 70.
2. Install fuse with label oriented with manufacturer, type, and size easily read.

C. Circuit Breakers:

1. Install in accordance with manufacturers published instructions and NFPA 70.
2. Install where indicated on Drawings, where required by equipment, and where required by NFPA 70.

3.3 FIELD QUALITY CONTROL

- A. Section 014000 - Quality Requirements: Field testing and inspection.
- B. Inspect and test in accordance with NETA ATS, except Section 4.
- C. Perform inspections and tests listed in NETA ATS, Section 7.5.

END OF SECTION

USPS MPF Specification Last Revised: 10/1/2023

SECTION 265100

INTERIOR LIGHTING
(LED - SOLID STATE)

PART 1 - GENERAL

1.1 SUMMARY

- A. Section Includes:
 - 1. Interior luminaires and accessories.
 - 2. Emergency lighting units.
 - 3. Exit signs.
 - 4. Ballast/Light emitting diode (LED) drivers.
 - 5. Light Sources.
 - 6. Luminaire accessories.
- B. Substitutions:
 - 1. Section 016000 - Product Requirements: Product substitutions permitted by manufacturers listed in Paragraph 2.1A.
- C. Related Documents: The Contract Documents, as defined in Section 011000 - Summary of Work, apply to the Work of this Section. Additional requirements and information necessary to complete the Work of this Section may be found in other Documents.
- D. Related Sections:
 - 1. Section 260500 - Common Work Results for Electrical: Basic electrical methods.
 - 2. Section 260623 – Lighting Control Devices.

1.2 REFERENCES

- A. As specified in Section 260500 – Common Work Results for Electrical.
- B. Illuminating Engineering Society (IES):
 - 1. IES LM-79 - (2008) Electrical and Photometric Measurements of Solid-State Lighting Products.
 - 2. IES LM-80 - (2015) Measuring Lumen Maintenance of LED Light Sources.
 - 3. IES TM-21 - (2011; Addendum B 2015) Projecting Long Term Lumen Maintenance of LED Light Sources.
- C. National Fire Protection Association (NFPA):
 - 1. NFPA 70 - National Electrical Code.
 - 2. NFPA 101 - Life Safety Code.
- D. National Electrical Manufacturers Association (NEMA):
 - 1. NEMA ANSILG C78.377 – (2017) Electric Lamps— Specifications for the Chromaticity of Solid State Lighting Products.
 - 2. NEMA SSL 1 – (2010) Electronic Drivers for Led Devices, Arrays, or Systems.
 - 3. NEMA SSL 3 - (2011) High-Power White LED Binning for General Illumination.
- E. Federal Communications Commission Parts 18.305, 18.307 (EMI RFI).
- F. American Society of Heating, Refrigerating and Air Conditioning, Inc.
 - 1. ANSI/ ASHRAE/ IES Standard 90.1.

- G. Underwriters Laboratories (UL)
 - 1. UL 1472 – (2015) UL Standard for Safety Solid-State Dimming Controls.
 - 2. UL 1598 – (2008; Reprint Oct 2012) Luminaires.
 - 3. UL 844 – (2012; Reprint Mar 2016) UL Standard for Safety Luminaires for Use in Hazardous (Classified) Locations.
 - 4. UL 8750 – (2015; Reprint Feb 2018) UL Standard for Safety Light Emitting Diode (LED) Equipment for Use in Lighting Products.
 - 5. UL 924 – (2016; Reprint Nov 2017) UL Standard for Safety Emergency Lighting and Power Equipment.

1.3 SUBMITTALS

- A. As specified in Section 260500 - Common Work Results for Electrical.
 - 1. Product Data: Submit catalog cuts, drawings, descriptive matter and lighting performance characteristics as required to completely define the materials and construction details employed, finishes applied, dimensions, hinging, latching and relamping provisions, and electrical characteristics.
 - 2. Assurance/Control Submittals:
 - a. Manufacturer's Instructions: Indicate application conditions and limitations of use stipulated by Product testing agency. Include instructions for storage, handling, protection, examination, preparation, and installation of Product.
- B. Section 017704 - Closeout Procedures and Training: Procedures for closeout submittals:
 - 1. Operation and Maintenance Data: Submit manufacturer's operation and maintenance instructions for each type of luminaire.

1.4 DEFINITIONS

- A. For LED luminaire light sources, "Useful Life" is the operating hours before reaching 70 percent of the initial rated lumen output (L70) with no catastrophic failures under normal operating conditions. This is also known as 70 percent "Rated Lumen Maintenance Life" as defined in IES LM-80.
- B. For LED luminaires, "Luminaire Efficacy" (LE) is the appropriate measure of energy efficiency, measured in lumens/watt. This is gathered from LM-79 data for the luminaire, in which absolute photometry is used to measure the lumen output of the luminaire as one entity, not the source separately and then the source and housing together.
- C. Total harmonic distortion (THD) is the root mean square (RMS) of all the harmonic components divided by the total fundamental current.

1.5 QUALITY ASSURANCE

- A. As specified in section 260500 – Common Work Results for Electrical.
- B. Products shall be tested, approved and labeled/listed by Underwriters Laboratories, Inc., or by a nationally recognized testing laboratory (NRTL).
- C. Electrical equipment and materials shall be new and within one year of manufacture, complying with the latest codes and standards. Re-built, refurbished and/or re-manufactured electrical equipment and materials shall not be furnished on this project.

1.6 MAINTENANCE

- A. Section 017704 - Closeout Procedures and Training: Procedures for closeout submittals.

- B. Extra Products: At completion of installation, deliver to the USPS Project Manager.
1. Two of each luminaire lens type.
 2. Each component type: Provide quantity for each unique ballast/driver, and LED array equal to 2 percent of luminaire total, but not less than two of each type.

PART 2 - PRODUCTS

2.1 LUMINAIRE MANUFACTURERS

- A. Subject to compliance with project requirements, manufacturers offering Products which may be incorporated in the Work include the following:
1. Alphabet Lighting, Tustin, CA (714) 259-9959.
 2. Barron/Exitronix, Glendale, AZ (888) 533-3948.
 3. Beghelli, Miramar, FL (954) 442-6600.
 4. Chloride Systems, Burgaw, NC (910) 259-1000.
 5. Cooper Lighting (Halo, Invue, Lumark, McGraw-Edison, Failsafe, Metalux, Portfolio, Sure-Lites), Peachtree City, GA (770)486-4800.
 6. Current Lighting (Albeo, Columbia, Compass, Dual-Lite, Kurt Versen, Forum, Lite Control, Prescolite), Greenville, SC (866) 758-0116.
 7. Day-Brite, Tupelo, MS (662) 842-7212.
 8. Edison-Price Lighting, Long Island City, NY (718) 685-0700.
 9. Elcast Lighting, Addison, IL (630) 543-5390.
 10. Evenlight, Trevese, PA (800) 872-0879.
 11. H.E. Williams, Carthage, MO (417) 358-4065.
 12. Holophane, Newark, OH (740) 345-9631.
 13. Indy Lighting, Fishers, IN (317) 849-1233.
 14. Intense Lighting LLC, Anaheim, CA (800) 691-5321.
 15. Isolite, Berwyn, PA (800) 888-5483.
 16. Kenall Manufacturing, Gurnee, IL (847) 360-8200.
 17. Killark Electric, Fenton, MO (314) 531-0460.
 18. Kirlin Lighting, Detroit, MI (313) 259-6400.
 19. Kramer Lighting, Sturtevant, WI (800) 236-6800.
 20. Kurtzon Lighting, Chicago, IL (773) 277-2121.
 21. LaMar Lighting, Farming Dale, NY (631) 777-7700.
 22. LightAlarms (Thomas & Betts) Montreal, ON (888) 552-6467.
 23. Lithonia Lighting (Gotham, Acuity, Sensor Switch), Conyers, GA (770) 922-9000.
 24. LSI Industries, Cincinnati, OH (513) 793-3200.
 25. Lumax Industries, Altoona, PA (814) 944-2537.
 26. Mercury Lighting, Fairfield, NJ (800) 637-2584.
 27. Omega Lighting, Tupelo, MS (800) 234-1890.
 28. Orion Energy Systems, Inc., Manitowoc, WI (800) 660-9340.
 29. Pheonix Products, Milwaukee, WI (414) 438-1200.
 30. Prudential Lighting, Los Angeles, CA (213) 746-0360.
 31. Solas Ray Lighting, Indianapolis, IN (800) 840-5635.
 32. Vista Lighting, Tupelo, MS (662) 690-4105.
 33. Zumtobel Staff, Highland, NY (800) 448-4131.

2.2 LUMINAIRE TYPES

- A. Type B4: Lithonia #FEML48-XXXX-IMAFL-MD-MVOLT-GZ10-40K-80CRI-STSL-SPD .
1. Description: 7" x 4 feet long enclosed and gasketed LED luminaire. UL listed for wet location.
 2. Lens: 4.5 inches Deep high impact, injection molded, acrylic lens; linear ribbed frosted, 0.08 inches thick.

3. Housing:
 - a. One piece, 5 VA fiberglass housing with stainless steel latches.
 - b. NEMA 4x, IP65 rated.
 4. Ballast/Driver:
 - a. LED high efficiency – 18W at 2900 Lumen, 24W at 3800 Lumen, 38W at 5600 Lumen, 51W at 7400 Lumen or 62W at 9200 Lumen. Wattage based on lumen package selected.
 - b. Integral 10 KV/5 kA surge protection device.
 5. Mounting: Surface ceiling or wall mounted.
 6. Lamps: 2900 Lumen, 3800 Lumen, 5600 Lumen, 7400 Lumen or 9200 Lumen LED array; 4000K rated 60,000 hours at LLD = 0.8.
 7. Marking: Luminaires are to be labeled on the interior side with lumen package used.
 8. Alternate Manufacturers:
 - a. Metalux #4VT2-LD5-X-DR100-UNV-L840-CD1-WL-SSL.
 - b. Columbia #LXEM4-40-XX-RFA-ED1-U-SSL.
 - c. Substitutions permitted: As listed in Paragraph 2.1A.
- B. Type CL2: Lithonia #ZLIN-L24-XXXX-FST-MVOLT-40K-80CRI-WH.
1. Description; 2 feet long, LED strip luminaire with protective lens/diffuser.
 2. Lens: Snap on frosted, diffused lens.
 3. Housing:
 - a. 20 gauge cold rolled steel housing with punched knockouts for mounting.
 - b. End plates shall be die-formed heavy gauge rolled steel with punched knockouts for through wiring.
 - c. White baked enamel finish with a minimum 90 percent reflectance.
 4. Ballast/Driver: LED high efficiency – 15W at 1800 Lumen, 19W at 2400 Lumen or 31W at 3700 Lumen. Wattage based on lumen package selected.
 5. Mounting:
 - a. Surface mounted to the underside of the ceiling. Attach luminaire to ceiling grid by means of a gripper hanger which attaches to any standard ceiling grid system.
 - b. For spaces without ceiling, suspend from structure with all-thread rods to required height.
 - c. Electrical Contractor to determine quantity of hangers required for either method.
 6. Lamps: 1800 Lumen, 2400 Lumen or 3700 Lumen LED arrays; 4000K rated 60,000 hours at LLD = 0.7.
 7. Marking: Luminaires are to be labeled on the interior side with lumen package used.
 8. Alternate Manufacturers:
 - a. Columbia Lighting #MPS2-40XX-FW-ED1-U.
 - b. Metalux #2SNLED-LD5-XX-LW-UNV-L840-HCD-1.
 - c. Substitutions permitted: As listed in Paragraph 2.1A.
- C. Type EM2: Lithonia #ELM4L-UVOLT-LTP-SDRT.
1. Description: Compact contemporary design LED emergency lighting unit with adjustable heads and lithium iron phosphate battery. Provide with line latching, solid-state voltage limiting charger, solid-state switching, low voltage disconnect, brownout circuit, overload, short-circuit protection test switch and power indicator light.
 2. Battery: Sealed, maintenance free, lithium iron phosphate, 11 Watt at 9.6 volt.
 3. Housing: White thermoplastic body, UL924 listed, all components meet the UL 94-0.5VA flame retardant standard.
 4. Mounting: Wall mounted.
 5. Voltage: 277 or 120. Refer to light fixture schedule on drawings.
 6. Lamps: 640 Lumens total, 2 at 3.3 Watt/9.6 Volt. (included).
 7. Alternate Manufacturers:
 - a. Beghelli #XLPLED1-AT-HO.
 - b. Evenlite #TEBL3W-SD.
 - c. Dual-Lite #EVHC12-I-06L.
 - d. Substitutions permitted: As listed in Paragraph 2.1A.

- D. Type EM3: Exitronix #RSL12N-42-1205-W-G2.
1. Description: Industrial design LED emergency lighting unit with adjustable heads and nickel cadmium battery. Provide with line latching, solid-state voltage limiting charger, solid-state switching, low voltage disconnect, brownout circuit, overload, short-circuit protection test switch and self-test/self-diagnostics.
 2. Battery: Sealed, maintenance free, nickel cadmium, 12 volt, with 42 Watt capacity.
 3. Housing: 20-gauge steel housing finished in white epoxy, powder coat finish, with hinged faceplate for ease of maintenance. UL924 listed, all components meet the UL 94-0.5VA flame retardant standard.
 4. Mounting: Wall mounted.
 5. Voltage: refer to drawing information.
 6. Lamps: 2 at 5 Watt, PAR 18 LED (included).
 7. Alternate Manufacturers:
 - a. Beghelli #EST12V-42-2SRE-AT.
 - b. Lightalarms #2P12N1/LED (Series).
 - c. Chloride #TNM50-M7F-2-IC.
 - d. Substitutions permitted: As listed in Paragraph 2.1A.
- E. Type EM4 (exterior egress doors): Lithonia #AFF-OEL-XXXXXX-UVOLT-LTP-SDRT-FCT.
1. Description: Wall Mounted UL wet location LED emergency lighting unit
 2. Ballast/Driver: LED high efficiency – 2.5W at 635 Lumen LED (forward throw).
 3. Housing: UL listed wet location (NEMA 4X) low profile, die-cast aluminum, sealed and gasketed. Finish by the USPS Project Manager.
 4. Battery: Lithium iron phosphate with self-diagnostics. 32 to 122 degrees F (standard), -22 to 122 degrees F (cold weather) , wet locations.
 5. Mounting: Surface wall.
 6. Voltage: refer to drawing information.
 7. Lamps: 2.5W at 635 Lumen LED array.
 8. Alternate Manufacturers:
 - a. Isolite #ELED-EM-WH-MB.
 - b. Compass #CUWZ-PC Series.
 - c. Compass #CUSO Series.
 - d. Sure-Lites #SELW25-NC-WH.
 - e. Substitutions permitted: As listed in Paragraph 2.1A.
- F. Type X1: Lithonia #LQM-S-W-3R-120/277-ELN-SD.
1. Description: Ceiling, end or wall mounted, single face LED exit sign with canopy. Self-powered and with self-diagnostics.
 2. Features: Red Letters, White Stencil, White Housing (verify colors with local jurisdiction). Injection molded UL94-5V rated polycarbonate frame and canopy.
 3. Mounting: Ceiling, back or end mounted.
 4. Battery: Maintenance free sealed Nickel Cadmium with long life, full recharge time of 24 hours max.
 5. Voltage: refer to drawing information.
 6. Lamps: LED lamp module.
 7. Alternate Manufacturers:
 - a. Sure-Lites #LPX7-X-SD.
 - b. Compass #CERSD Series.
 - c. Substitutions permitted: As listed in Paragraph 2.1A.
- G. Type X2: Lithonia #LQM-S-W-3R-120/277-ELN-SD.
1. Description: Ceiling or end mount, double face LED exit sign with canopy. Self-powered and with self-diagnostics.

2. Features: Red Letters, White Stencil, White Housing (verify colors with local jurisdiction). Injection molded UL94-5V rated polycarbonate frame and canopy. Two bottom apertures snap out to emit downlight as required.
3. Mounting: Ceiling or end-mount.
4. Battery: Maintenance free sealed nickel-cadmium with long life, full recharge time of 24 hours maximum.
5. Voltage: refer to drawing information.
6. Lamps: LED lamp module.
7. Alternate Manufacturers:
 - a. Sure-Lites #LPX7-X-SD.
 - b. Compass #CERSD Series.
 - c. Substitutions permitted: As listed in Paragraph 2.1A.

2.3 LUMINAIRES

- A. Provide luminaires as indicated in luminaire schedule and details on project plans. Provide luminaires complete with light sources of quantity, type and wattage indicated. Provide all luminaires of the same type by the same manufacturer. Luminaires must be specifically designed for use with the driver or ballast and light source provided.
- B. LED Luminaires:
 1. Install ballast/drivers, LED arrays and specified accessories at the factory.
 2. Luminaires must have a minimum 5 year manufacturer's warranty.
 3. Luminaires must have a minimum L70 lumen maintenance value of 50,000 hours as calculated by IES TM-21, with data obtained per IES LM-80 requirements.
 4. Luminaire drive current value must be identical to that provided by test data for luminaire in question.
 5. Luminaires must be listed with the Design Lights Consortium 'Qualified Products List' when falling into category of "General Application" luminaires, i.e. Interior Directional, Display Case, Troffer, Linear Ambient, or Low/High Bay. Requirements are shown in the Design Lights Consortium "Technical Requirements Table" at <https://data.energystar.gov/dataset/EPA-Recognized-Laboratories-For-Lighting-Products/jgwf-7qrr>.
 6. Provide Department of Energy 'Lighting Facts' label for each luminaire.
- C. Luminaires for hazardous locations:
 1. In addition to requirements stated herein, provide LED luminaires for hazardous locations which conform to UL 844 or which have Factory Mutual certification for the class and division indicated.

2.4 LED DRIVERS

- A. NEMA SSL 1, UL 8750. LED drivers must be electronic, UL Class 1, constant-current type and comply with the following requirements:
 1. Output power (watts) and luminous flux (lumens) as shown in luminaire schedule for each luminaire type to meet minimum luminaire efficacy (LE) value provided.
 2. Power Factor (PF) greater than or equal to 0.9 over the full dimming range when provided.
 3. Current draw Total Harmonic Distortion (THD) of less than 20 percent.
 4. Class A sound rating.
 5. Operable at input voltage of 120-277 volts at 60 hertz.
 6. Minimum 5 year manufacturer's warranty.
 7. RoHS compliant.
 8. Integral thermal protection that reduces or eliminates the output power if case temperature exceeds a value detrimental to the driver.
 9. UL listed for dry or damp locations typical of interior installations.
 10. LED driver shall tolerate sustained open circuit and short circuit output conditions without damage.

11. LED driver shall comply with the requirements of the FCC rules and regulations, Title 47 CFR Part 15 Non-Consumer (Class A).

2.5 LIGHT SOURCES

- A. NEMA ANSLG C78.377, NEMA SSL 3. Provide type and wattage as indicated in luminaire schedule on project plans.
- B. LED arrays shall have a correlated color temperature (CCT) of 4000K; minimum color rendering index (CRI) value of 80.
- C. High power, white light output utilizing phosphor conversion (PC) process or mixed system of colored LEDs, typically red, green and blue (RGB).
- D. Provide light source color consistency by utilizing a binning tolerance within a 4 step McAdam ellipse.
- E. Luminaire shall have door frame and lens compatible for use with LED arrays and integral airflow ventilation system.

2.6 LED EMERGENCY DRIVERS

- A. Provide LED emergency driver with automatic power failure detection, test switch and LED indicator (or combination switch/indicator) located on luminaire exterior and provide self-diagnostic function integral to emergency driver. Integral nickel cadmium or lithium iron phosphate battery is required to supply a minimum of 90 minutes of emergency power at 700 Lumens (at 100 Lumens/Watt). Driver must be RoHS compliant, rated for installation in plenum-rated spaces and damp locations, and be warranted for a minimum of five years.

2.7 LUMINAIRE SUPPORT HARDWARE

- A. Wire:
 1. ASTM A641/A641M; Galvanized, soft tempered steel, minimum 0.11 inches in diameter, or galvanized, braided steel, minimum 0.08 inches in diameter.
- F. Threaded Rods:
 1. Threaded steel rods, 3/16 inch diameter, zinc or cadmium coated.
- G. Straps:
 1. Galvanized steel, one inch by 3/16 inch, conforming to ASTM A653/A653M, with a light commercial zinc coating or ASTM A1008/A1008M with an electrodeposited zinc coating conforming to ASTM B633, Type RS.

2.8 EQUIPMENT IDENTIFICATION

- A. Each item of equipment must have a nameplate bearing the manufacturer's name, address, model number, and serial number securely affixed in a conspicuous place; the nameplate of the distributing agent will not be acceptable.
- B. Provide labeled luminaires in accordance with UL 1598 requirements. All luminaires must be clearly marked for operation of specific light sources and ballasts or drivers. Note the following light source characteristics in the format "Use Only _____":
 1. Correlated color temperature (CCT) and color rendering index (CRI) for all luminaires.

2. All markings related to light source type must be clear and located to be readily visible to service personnel, but unseen from normal viewing angles when light sources are in place. Ballasts or drivers must have clear markings indicating multi-level outputs and indicate proper terminals for the various outputs.

2.9 FACTORY APPLIED FINISH

- A. Provide all luminaires and lighting equipment with factory-applied painting system that as a minimum, meets requirements of NEMA 250 corrosion-resistance test.

2.10 RECESS- AND FLUSH-MOUNTED LUMINAIRES

- A. Provide access to lamp and ballast from bottom of luminaire. Provide trim for the exposed surface of flush-mounted luminaires as indicated on project drawings and specifications.

2.11 SUSPENDED LUMINAIRES

- A. Provide hangers capable of supporting twice the combined weight of luminaires supported by hangers. Provide with swivel hangers to ensure a plumb installation. Provide cadmium-plated steel with a swivel-ball tapped for the conduit size indicated. Hangers must allow fixtures to swing within an angle of 45 degrees. Brace pendants 4 feet or longer to limit swinging. Single-unit suspended luminaires must have twin-stem hangers. Multiple-unit or continuous row luminaires must have a tubing or stem for wiring at one point and a tubing or rod suspension provided for each unit length of chassis, including one at each end. Provide rods in minimum 0.25 inch diameter.

PART 3 - EXECUTION

3.1 EXAMINATION

- A. As specified in Section 260500 – Common Work Results for Electrical.

3.2 INSTALLATION

- A. Electrical installations must conform to IEEE C2, NFPA 70, and to the requirements specified herein. Install luminaires to meet the requirements of ASHRAE 90.1 and ASHRAE 189.1. To encourage consistency and uniformity, install luminaires of the same manufacture and model number when residing in the same facility or building.
- B. Luminaires:
 1. Set luminaires plumb, square, and level with ceiling and walls, in alignment with adjacent luminaires and secure in accordance with manufacturers' directions and approved drawings. Installation must meet requirements of NFPA 70. Obtain approval of the exact mounting height on the job from client before commencing installation and, where applicable, after coordinating with the type, style, and pattern of the ceiling being installed.
 2. Recessed and semi-recessed luminaires must be independently supported from the building structure by a minimum of four wires, straps or rods per luminaire and located near each corner of the luminaire. Ceiling grid clips are not allowed as an alternative to independently supported luminaires.
 3. Round luminaires or luminaires smaller in size than the ceiling grid must be independently supported from the building structure by a minimum of two wires, straps or rods per luminaire,

spaced approximately equidistant around. Do not support luminaires by acoustical tile ceiling panels.

- a. Where luminaires of sizes less than the ceiling grid are indicated to be centered in the acoustical panel, support each independently and provide at least two 3/4 inch metal channels spanning, and secured to, the ceiling tees for centering and aligning the luminaire. Provide wires, straps, or rods for luminaire support in this section.

C. Suspended Luminaires:

1. Provide suspended luminaires with swivel hangers so that they hang plumb and level. The stem, canopy and luminaire must be capable of 45 degree swing. Pendants, rods, or chains, 4 feet or longer excluding luminaire, must be braced to prevent swaying using three cables at 120 degree separation.
2. Suspended luminaires in continuous rows must have internal wireway systems for end to end wiring and must be properly aligned to provide a straight and continuous row without bends, gaps, light leaks or filler pieces.
3. Match supporting pendants with supported luminaire. Canopies must be finished to match the ceiling and must be low profile unless otherwise shown.
4. Maximum distance between suspension points must be 10 feet or as recommended by the manufacturer, whichever is less.

D. Locate ceiling luminaires as indicated on reflected ceiling plan.

E. Install surface mounted luminaires and exit luminaire signs plumb and adjust to align with building lines and with each other. Secure to prevent movement. Mount exit signs to outlet box mounted flush in wall or ceilings. Outlet box for ceiling mounted exit signs: Connect to rigid conduit system.

F. Install recessed luminaires using accessories and firestopping materials to meet regulatory requirements for fire rating. In fire rated ceilings, recessed luminaires must carry 1 hour UL fire rating classification.

G. Install earthquake clips to secure recessed grid-supported luminaires in place.

H. Install wall mounted luminaires, emergency lighting units and exit luminaire signs at height as scheduled and shown on drawings.

I. Install accessories furnished with each luminaire.

J. Bond products and metal accessories to branch circuit equipment grounding conductor.

K. Install specified light sources in each emergency lighting unit, exit luminaire sign, and luminaire.

L. Wire exit signs and emergency lighting units ahead of the local switch, to the normal lighting circuit located in the same room or area.

M. Luminaire whips shall be steel or aluminum. M/C cable shall be permissible for luminaire whips/connections. Luminaire whips/connections shall be made with a minimum of #12 AWG copper conductors. Equipment grounding conductors shall be provided in all luminaire whips and/or connections.

1. All luminaire whips shall be supported to luminaire support wire/cable with an approved fastener equal to an Erico "KX" flexible conduit hanger or other UL listed supports and fasteners.

N. Luminaires are not to be used as a raceway unless stamped for use as raceway by manufacturer. Single luminaire in lay-in ceilings shall not be used for raceway and shall be connected to an outlet box located within six feet (6') of fixture with flexible conduit or luminaire whips.

3.3 FIELD QUALITY CONTROL

A. Section 014000 - Quality Requirements: Field testing and inspection.

- B. Operate each luminaire after installation and connection. Inspect for proper connection and operation.
- C. Final acceptance will be based on measurement of initial lighting levels after required hours of burn in as specified in USPS Mail Processing Facility Design Criteria, not maintained lighting levels.

3.4 WARRANTY

- A. Provide a written 5 year on-site replacement warranty for material, luminaire finish, and workmanship. On-site replacement includes transportation, removal, and installation of new products.
 - 1. Include finish warranty to include failure and substantial deterioration such as blistering, cracking, peeling, chalking, or fading.
 - 2. Material warranty must include:
 - a. All drivers.
 - b. Replacement when more than 10 percent of LED sources in any lightbar or subassembly are defective or non-starting.
- B. Warranty period must begin on date of beneficial occupancy. Provide the USPS Project Manager with signed warranty certificates prior to final payment.

3.5 ADJUSTING

- A. Aim and adjust luminaires as directed by the USPS Project Manager.
- B. Position exit luminaire sign directional arrows as indicated.

3.6 CLEANING

- A. Section 017300 - Execution: Cleaning installed work.
- B. Clean electrical parts to remove conductive and deleterious materials.
- C. Remove dirt and debris from enclosures.
- D. Clean photometric control surfaces as recommended by manufacturer.
- E. Clean finishes and touch up damage.

END OF SECTION

USPS MPF Specification Last Revised: 10/1/2023

SECTION 265600
EXTERIOR LIGHTING

PART 1 - GENERAL

1.1 SUMMARY

- A. Section Includes:
 - 1. Exterior luminaires and accessories.
 - 2. Poles.
 - 3. Ballast/Drivers.
- B. Substitutions:
 - 1. Section 016000 – Product Requirements: Product substitutions permitted by manufacturers listed in Paragraph 2.1A.
- C. Related Documents: The Contract Documents, as defined in Section 011000 - Summary of Work, apply to the work of this section. Additional requirements and information necessary to complete the work of this section may be found in other documents.
- D. Related Sections
 - 1. Section 033000 - Cast-in-Place Concrete: Concrete for pole foundation.
 - 2. Section 260500 - Common Work Results for Electrical: Basic electrical methods.
 - 3. Section 260623 - Lighting Control Devices.

1.2 REFERENCES

- A. As referenced in Section 260500 – Common Work Results for Electrical.
- B. Illuminating Engineering Society North America (IESNA):
 - 1. IESNA RP-8 - Recommended Practice for Roadway Lighting.
 - 2. IESNA RP-20 – Recommended Practice for Lighting for Parking Facilities.
 - 3. IESNA RP-33 - Recommended Practice for Lighting for Exterior Environments.
- C. Federal Communications Commission Parts 18.305, 18.307 (EMI RFI).
- D. American Society of Heating, Refrigerating and Air Conditioning, Inc.
 - 1. ANSI/ ASHRAE/ IES Standard 90.1.

1.3 SUBMITTALS

- A. As specified in Section 260500 – Common Work Results for Electrical.
 - 1. Product Data:
 - a. Luminaire dimensions, ratings, and performance data.
 - b. Complete computer data printout of illumination levels based on a 5 by 5 foot grid pattern.
 - 2. Shop Drawings:
 - a. Indicate dimensions and components for each luminaire which is not a standard Product of the manufacturer.
 - b. Indicate illumination levels in accordance with layout and scheduled luminaires indicated on Drawings.

1.4 QUALITY ASSURANCE

- A. As specified in Section 260500 – Common Work Results for Electrical.

1.5 DELIVERY, STORAGE, AND HANDLING

- A. As specified in Section 260500 – Common Work Results for Electrical.

1.6 MAINTENANCE

- A. Section 017704 – Closeout Procedures and Training: Procedures for closeout submittals.
- B. Extra Products: At completion of installation, deliver to the USPS Project Manager.
 - 1. Each component type: Provide quantity for each unique ballast/driver, surge protector and LED array equal to 2 percent of luminaire total, but not less than two of each type.

PART 2 - PRODUCTS

2.1 LUMINAIRE MANUFACTURERS

- A. Subject to compliance with project requirements, manufacturers offering Products which may be incorporated in the Work include the following:
 - 1. Alphabet Lighting, Tustin, CA (714) 259-9959.
 - 2. Architectural Landscape Lighting, Santa Ana, CA 92704 (714) 668-1107.
 - 3. Barron Lighting Group (Trace-Lite), Phoenix, AZ 85027 (888) 533-3948.
 - 4. Bronzelite Commercial Landscape Lighting, (800) 273-1569.
 - 5. CGF Design Inc., Morton Grove, IL (847) 815-5079.
 - 6. Cooper Lighting (Invue, Lumark, Lumiere, Portfolio, McGraw-Edison), Peachtree City, GA (770)486-4800.
 - 7. Current Lighting (Architectural Area Lighting, Beacon, Kim, Prescolite), Greenville, SC (866) 758-0116.
 - 8. Deco Lighting, Commerce, CA (800) 613-3326.
 - 9. Gardco/Philips Lighting, San Leandro, CA (800) 227-0758.
 - 10. Gotham Lighting, Conyers, GA (800) 315-4982.
 - 11. Hadco Lighting, Littlestown, PA (717) 359-7131.
 - 12. Holophane, Newark, OH (740) 345-9631.
 - 13. Hydrel Architectural and Landscape Products, Sylmar, CA 91342 (818) 362-9465.
 - 14. Intense Lighting, Anaheim, CA (800) 961-5322.
 - 15. Kenall Manufacturing, Gurnee, IL (847) 360-8200.
 - 16. Kirlin Lighting, Detroit, MI (313) 259-6400.
 - 17. Ligman Lighting USA, Hillsboro, OR (503) 645-0500.
 - 18. Lithonia Lighting, Conyers, GA (770) 922-9000.
 - 19. LSI Industries, Cincinnati, OH 513) 793-3200.
 - 20. McPhilben Lighting, San Leandro, CA (510) 357-6900.
 - 21. Pathway Lighting, Old Saybrook, CT (800) 342-0592.
 - 22. Quality Lighting, Franklin Park, IL (847) 451-0090.
 - 23. Visionaire Lighting, Rancho Dominguez, CA (310) 512-6480.
 - 24. Wide-Lite, San Marcos, TX (512) 392-5821.

2.2 LUMINAIRE TYPES

- A. Type MH3 (exterior): Lithonia #MRWLED-XX-40K-SRX-MVOLT.
1. Description: 18 inch diameter half cylinder wall mounted full cut-off, solid state, LED luminaire. Lens door is fully gasketed with one-piece solid silicone and UL listed for wet locations.
 2. Lens: Precision molded acrylic.
 3. Housing: Die-cast single piece aluminum housing. Finish by the USPS Project Manager.
 4. Ballast/Driver: 20W at 2200 Lumen, 29W at 3000 Lumen, 40W at 4500 Lumen or 61W at 6000 Lumen. Wattage based on lumen package selected.
 5. Mounting: Surface wall.
 6. Voltage: refer to drawing information
 7. Lamp: 2200 Lumen, 3000 Lumen, 4500 Lumen or 6000 Lumen LED array; 4000K, 60,000 hours @ LLC = 0.9.
 8. Label: UL listed for wet locations; IP65 rated.
 9. Warranty: Full five (5) year factory replacement warranty (internal components).
 10. Alternate Manufacturers:
 - a. Gardco/Philips #104L-XXL-XXX-NW-G1-X.
 - b. Beacon #QSP2-XXL-XX-4K7-X-UNV.
 - c. Lithonia #WSRLED-XX-40K-SRX-MVOLT.
 - d. McGraw Edison #ISS-XA1X-XXX-U-XXX.
 - e. Barron Trace-Lite #TLED111P-XX-VS.
 - f. Deco Lighting #D440-LED-XX-40-UNV-D-XX.
 - g. Substitution permitted: As listed in Paragraph 2.1A.
- B. Type PL1 (exterior): Lithonia #DSXCSLED-XXC-XXXX-40K-T5M-MVOLT-SRM.
1. Description: Low profile, square, full cut-off canopy light U.L. listed for wet locations.
 2. Housing/Lens: Die-cast aluminum housing with tempered, flat glass lens and pressure stabilizing vent. Finish by USPS Project Manager.
 3. Ballast/Driver: 26W at 2700 Lumen thru 107W at 11,000 Lumen. Wattage based on lumen package selected.
 4. Mounting: refer to drawing information
 5. Lamp: 2700 Lumen thru 11,000 Lumen LED array; 4000K, 60,000 hours; LLD=0.85.
 6. Voltage: refer to drawing information.
 7. Label: U.L. listed for wet locations; IP66 rated with 5-year factory warranty.
 8. Alternate manufacturers:
 - a. Philips/Gardco #SFCX-5W-48L-XXX-NW-G2-UNV.
 - b. Deco Lighting #D533-PRO-XX-40-U-5-SU (Surface only).
 - c. Deco Lighting #533R-PRO-XX-40-U-5 (recessed only).
 - d. McGraw-Edison #CNC-XXX-LED-E1-XX (Surface only).
 - e. McGraw-Edison #LRC-B-XX-X-LED-E1-XXX (recessed only).
 - f. Substitution permitted: As listed in Paragraph 2.1A.
- C. Type PL2 (exterior): Lumark #XTORXB-W-XX.
1. Description: Slim, low profile, wall mounted, full cut-off LED luminaire. U.L. listed for wet locations.
 2. Housing/Lens: Die-cast aluminum housing with flat glass bottom lens.
 3. Ballast/Driver: 12W at 1400 Lumen, 18W at 2100 Lumen, 26W at 2700 Lumen or 38W at 4200 Lumen. Wattage based on lumen package selected.
 4. Mounting: Surface, wall mounted with recessed outlet box - 4 inch profile.
 5. Lamp: 1400 Lumen, 2100 Lumen, 2700 Lumen or 4200 Lumen LED array; 4000K, 72,000 hours; LLD=0.90.
 6. Voltage: refer to drawing information.
 7. Label: U.L. listed for wet locations; 5 year factory warranty.
 8. Alternate manufacturers:
 - a. Current Lighting #EXO-5G1-XO-4K7-FT-UNV-XXX.
 - b. Substitution permitted: As listed in Paragraph 2.1A.
 - h.

2.3 LUMINAIRES

- A. Provide luminaires as indicated in luminaire schedule and details on project plans. Provide luminaires complete with light sources of quantity, type and wattage indicated. Provide all luminaires of the same type by the same manufacturer. Luminaires must be specifically designed for use with the driver or ballast and light source provided.
- B. LED Luminaires:
 - 1. Install ballast/drivers, LED arrays and specified accessories at the factory.
 - 2. Luminaires must have a minimum 5 year manufacturer's warranty.
 - 3. Luminaires must have a minimum L70 lumen maintenance value of 50,000 hours as calculated by IES TM-21, with data obtained per IES LM-80 requirements.
 - 4. All luminaires shall be fused. Locate fuses within handhole of pole for pole mounted luminaires.
 - 5. Voltage: refer to drawing information .
 - 6. Provide individual surge protectors within handhole of each pole mounted luminaire. Branch circuit breakers feeding pole mounted luminaires shall also be equipped with surge protection.

2.4 LED DRIVERS

- A. NEMA SSL 1, UL 8750. LED drivers must be electronic, UL Class 1, constant-current type and comply with the following requirements:
 - 1. Output power (watts)and luminous flux (lumens) as shown in luminaire schedule for each luminaire type to meet minimum luminaire efficacy (LE) value provided.
 - 2. Power Factor (PF) greater than or equal to 0.9 over the full dimming range when provided.
 - 3. Current draw Total Harmonic Distortion (THD) of less than 20 percent.
 - 4. Class A sound rating.
 - 5. Operable at input voltage of 120-277-480 volts at 60 hertz.
 - 6. Minimum 5-year manufacturer's warranty.
 - 7. RoHS compliant.
 - 8. Integral thermal protection that reduces or eliminates the output power if case temperature exceeds a value detrimental to the driver.
 - 9. UL listed for wet locations typical of exterior installations.
 - 10. LED driver shall tolerate sustained open circuit and short circuit output conditions without damage.
 - 11. LED driver shall comply with the requirements of the FCC rules and regulations, Title 47 CFR Part 15 Non-Consumer (Class A).

2.5 LIGHT SOURCES

- A. NEMA ANSLG C78.377, NEMA SSL 3. Provide type and wattage as indicated in luminaire schedule on project plans.
- B. LED arrays shall have a correlated color temperature (CCT) of 4000K; minimum color rendering index (CRI) value of 70.
- C. High power, white light output utilizing phosphor conversion (PC) process or mixed system of colored LEDs, typically red, green and blue (RGB).
- D. Provide light source color consistency by utilizing a binning tolerance within a 4 step McAdam ellipse.

2.6 EQUIPMENT IDENTIFICATION

- A. Each item of equipment must have a nameplate bearing the manufacturer's name, address, model number, and serial number securely affixed in a conspicuous place; the nameplate of the distributing agent will not be acceptable.

- B. Provide labeled luminaires in accordance with UL 1598 requirements. All luminaires must be clearly marked for operation of specific light sources and ballasts or drivers. Note the following light source characteristics in the format "Use Only _____".
- C. Correlated color temperature (CCT) and color rendering index (CRI) for all luminaires.
- D. All markings related to light source type must be clear and located to be readily visible to service personnel, but unseen from normal viewing angles when light sources are in place. Drivers must have clear markings indicating multi-level outputs and indicate proper terminals for the various outputs.

PART 3 - EXECUTION

3.1 INSTALLATION

- A. Provide 3000 PSI minimum concrete for lighting poles bases at locations indicated, in accordance with Section 033000 and details shown on drawings.
- B. Install poles plumb. Provide double nuts to adjust plumb. Grout around each base and provide bolt covers.
- C. Bond luminaires, metal accessories and metal poles to branch circuit equipment grounding conductor. Provide supplementary 3/4 inch x 10 foot copper clad rod with #2/AWG/copper grounding electrode conductor at each pole.

3.2 FIELD QUALITY CONTROL

- A. Conform to Section 014000: Quality Requirements.
- B. Operate each luminaire after installation and connection. Inspect for improper connections and operation.
- C. Measure illumination levels to verify conformance with layout and performance requirements.
- D. Take measurements during night sky, without moon or with heavy overcast clouds effectively obscuring moon.

3.3 ADJUSTING

- A. Aim and adjust luminaires to provide illumination levels and distribution as directed.

3.4 CLEANING

- A. Conform to Section 017300 -Execution: Cleaning and protecting installed work.
- B. Clean electrical parts to remove conductive and deleterious materials.
- C. Remove dirt and debris from enclosure, pole, and base.
- D. Clean photometric control surfaces as recommended by manufacturer.
- E. Clean finishes and touch up damage.

3.5 PROTECTION OF FINISHED WORK

- A. Conform to Section 017300 – Execution: Protecting installed work.

END OF SECTION

USPS MPF Specification Last Revised: 10/1/2023

SECTION 311000

SITE CLEARING

PART 1 - GENERAL

1.1 SUMMARY

- A. Section Includes:
1. Cleaning site of debris, grass, trees and other plant life in preparation for site or building excavation Work.
 2. Protection of existing structures, trees or vegetation indicated to remain.
 3. Stripping topsoil from areas indicated.
- B. Related Documents: The Contract Documents, as defined in Section 011000 - Summary of Work, apply to the Work of this Section. Additional requirements and information necessary to complete the Work of this Section may be found in other Documents.
- C. Related Sections:
1. Section 013543 - Environmental Procedures: Recycling and reuse of waste materials.
 2. Section 024113 - Selective Site Demolition: Demolition and removal of site structures.
 3. Section 312000 - Earth Moving: Cutting, filling, and grading for proposed site improvements.

1.2 QUALITY ASSURANCE

- A. Regulatory Requirements:
1. Obtain required permits and licenses in accordance with requirements of Federal Clean Water Act (CWA) and Water Quality Act (WQA). File Notice of Intent (NOI) with United States Environmental Protection Agency, or appropriate state agency where project is located.
 2. Provide temporary erosion control systems as indicated on Drawings or as directed by Owner's Representative to protect adjacent properties and water resources from erosion and sedimentation.
 3. CWA (1972) and WQA (1987) Requirements:
 - a. Where Work on this project will disturb 1 or more acres, do not start Work without obtaining a "National Pollution Discharge Elimination System" (NPDES) permit governing discharge of storm water from project site for duration of Contract. Prepare and obtain approval of a "Storm Water Pollution Prevention Plan" (SWP³) that includes monitoring of erosion control measures for duration of Contract.
 - b. Provide storm water management in accordance with NPDES permit, SWP³ and for any enforcement action taken or imposed by Federal or State agencies, including cost of fines, construction delays and remedial actions resulting from failure to comply with all provisions of NPDES permit and SWP³.
 - c. Keep SWP³ on site and make available for inspection by appropriate authority having jurisdiction at any time.

1.3 PROJECT CONDITIONS OR SITE CONDITIONS

- A. Existing Conditions:
1. Notify the Contracting Officer of variations to conditions or discrepancies in actual site conditions prior to start of site preparation Work.

2. Traffic: Conduct operations and removal of debris with minimum interference to roads, streets, walks, and other adjacent facilities. Do not close or obstruct streets, walks or other facilities without permission from authorities having jurisdiction.
3. Protections: Provide protection for safe passage of persons around area of site preparation. Take precautions and conduct operations to prevent injury to adjacent buildings, structures, other facilities, and persons.
 - a. Provide interior and exterior shoring, bracing, or support to prevent movement, settlement or collapse of structures to be demolished and adjacent facilities to remain.

PART 2 - PRODUCTS

2.1 MATERIALS

- A. Topsoil: Friable clay loam surface soil containing humus, organic matter, found in a depth of not less than 4 inches free of subsoil, clay lumps, stones, and other objects over 2 inches in diameter, and without weeds, roots, and other unsuitable material.

PART 3 - EXECUTION

3.1 EXAMINATION

- A. Section 017300 - Execution: Verification of existing conditions before starting work.
- B. Verification of Conditions: Verify that field measurements, surfaces, substrates and conditions are as required, and ready to receive Work.
 1. Locate existing utilities as specified in Section 312000.
 2. Verify that survey benchmark and intended elevations for the Work are as indicated and are not located in an area that may be damaged.
 3. Verify that existing plant life and clearing limits are clearly tagged, identified and marked in such a manner as to insure their safety throughout construction operations.
- C. Report in writing to Contracting Officer prevailing conditions that will adversely affect satisfactory execution of the Work of this Section. Do not proceed with Work until unsatisfactory conditions have been corrected.
- D. By beginning Work, Contractor accepts conditions and assumes responsibility for correcting unsuitable conditions encountered at no additional cost to the United States Postal Service.

3.2 PREPARATION

- A. Provide temporary erosion control systems as indicated on Drawings or as directed by Contracting Officer to protect project site and adjacent properties and water resources from erosion and sedimentation.

3.3 CLEARING

- A. Clear areas required for access to site and execution of Work.
- B. Remove trees, shrubs, grass, other vegetation, improvements, or obstructions interfering with installation of Work as indicated on Drawings. Removal includes digging out stumps and roots. Fill depressions caused by clearing and grubbing operations to subgrade elevation. Prevent water ponding.

Place suitable fill material in horizontal layers not exceeding 8 inches loose depth, and compact as specified herein and in Section 312000.

- C. Remove grass, trees, plant life, stumps and all other construction debris from site.
 - 1. Collect, recycle, reuse, and dispose of demolished materials as specified in Section 013543 - Environmental Procedures and as approved by the U.S. Postal Service in the Solid Waste Management and Environmental Protection Plan.
 - a. Mulch: Identify organic debris that is free of disease, pest infestation, and chemical contamination and that is suitable for recycling on site. Chip and compost suitable organic debris for use as mulch on site. Stockpile where indicated on Drawings or directed by Contracting Officer. Coordinate with mulch requirements of Section 329200 - Turf and Grasses and Section 329300 - Plants.

3.4 TOPSOIL EXCAVATION

- A. Strip topsoil from areas that are indicated to be filled, excavated, landscaped, or re-graded to depth that prevents contact with underlying subsoil or unsuitable material. Where trees are indicated to remain, stop topsoil stripping sufficient distance from tree to prevent damage to main root system.
- B. Cut heavy growths of grass from areas prior to start of stripping. Remove heavy growths of grass along with clearing of other vegetation materials.
- C. Topsoil: Organic surface soil found in depth not less than 6 inches.
- D. Satisfactory Topsoil: Soil reasonably free of subsoil, clay lumps, stones and other objects over 2 inches in diameter, weeds, roots, and other unsuitable material.
- E. Stockpile topsoil where indicated on Drawings or directed by Contracting Officer. Construct stockpile areas to positively drain surface water. Cover stockpile areas as required to prevent windblown dust. Dispose of unsuitable topsoil off-site as specified clearing, unless directed otherwise by Contracting Officer. Dispose of excess topsoil off-site as specified for clearing, unless directed otherwise by Contracting Officer.

3.5 REMOVAL

- A. Remove debris, rock, extracted plant life, paving, curbs, and other structures indicated on Drawings as specified in Section 024113.
 - 1. Collect, recycle, reuse, and dispose of demolished materials as specified in Section 013543 - Environmental Procedures and as approved by the U.S. Postal Service in the Solid Waste Management and Environmental Protection Plan.

3.6 PROTECTION

- A. Protect existing streets, structures, and utilities as specified in Section 312000.
- B. Protect trees, plant growth, and features indicated to remain.
- C. Protect natural resources as specified in Section 013543 - Environmental Procedures and as approved by the U.S. Postal Service in the Solid Waste Management and Environmental Protection Plan.

END OF SECTION

SECTION 312000

EARTH MOVING

PART 1 - GENERAL

1.1 SUMMARY

- A. Section Includes:
1. Preparation of subgrade for building, slabs, walks, pavements, and other sitework.
 2. Rough and finish grading.
 3. Excavation for filling and grading.
 4. Filling and subgrade preparation.
 5. Geotechnical Data
- B. Related Documents: The Contract Documents, as defined in Section 011000 - Summary of Work, apply to the Work of this Section. Additional requirements and information necessary to complete the Work of this Section may be found in other Documents.
- C. Related Sections:
1. Section 013543 - Environmental Procedures: Recycling and reuse of waste materials, and protection of natural resources
 2. Section 024113 - Selective Site Demolition: Demolition and removal of designated existing site items.
 3. Section 311000 - Site Clearing: Clearing site of debris, grass, trees, and other plant life.
 4. Section 312300 - Excavation and Fill: Earthwork for structures, utilities, and pavement.
 5. Section 313200 - Soil Stabilization: Lime, cement, fly ash, and geotextile subgrade stabilizers.
 6. Section 312500 - Erosion and Sedimentation Controls: Temporary and permanent erosion control and slope protection systems.
 7. Section 312317 - Rock Excavation: Removal of rock during excavation.
 8. Section 329113 - Soil Preparation: Placing topsoil and fine grading.

1.2 REFERENCES

- A. American Society for Testing and Materials (ASTM):
1. ASTM C 136 - Method for Sieve Analysis of Fine and Course Aggregates.
 2. ASTM D 698 - Test Method for Laboratory Compaction Characteristics of Soil Using Standard Effort.
 3. ASTM D 1556 - Test Method for Density of Soil in Place by the Sand-Cone Method.
 4. ASTM D 1557 - Test Method for Laboratory Compaction Characteristics of Soil Using Modified Effort.
 5. ASTM D 2167 - Test Method for Density and Unit Weight of Soil In-Place by the Rubber Balloon Method.
 6. ASTM D 2487 - Classification of Soils for Engineering Purposes (Unified Soil Classification System).
 7. ASTM D 2922 - Test Methods for Density of Soil and Soil- Aggregate in Place by Nuclear Methods (Shallow Depth).
 8. ASTM D 3017 - Test Method for Moisture Content of Soil and Rock in Place by Nuclear Methods (Shallow Depth)
 9. STM D 4318 - Test Method for Liquid Limit, Plastic Limit, and Plasticity Index of Soils.
- B. American Association of State Highway and Transportation Officials (AASHTO):
1. AASHTO T 88 - Particle Size Analysis of Soils

1.3 DEFINITIONS

- A. Building Area Subgrade Pad: Portion of site directly beneath and within a line 10 feet 0 inches beyond building and appurtenances including limits of any future building expansion areas indicated on Drawings.

1.4 SUBMITTALS

- A. Section 013300 - Submittal Procedures: Procedures for submittals.
 - 1. Shop Drawings:
 - a. Submit drawings or details indicating proposed alternate earthwork procedures or proposed procedures not indicated in Contract Documents.
 - b. Submit drawings or details of design for use of fabrics or geogrids.
 - 2. Assurance/Control Submittals:
 - a. Material Source: Submit name of imported materials suppliers. Provide materials from same source throughout the Work. Change of source requires Contracting Officer approval.
 - b. Test Reports: Submit the following reports directly to Contracting Officer from Testing Laboratory, with copy to Contractor. Prepare reports in conformance with Section 014000 - Quality Requirements:
 - 1) Test reports on borrow material.
 - 2) Verification of each footing subgrade.
 - 3) Field density test reports.
 - 4) Optimum moisture-maximum density curve for each type of soil encountered.
 - 5) Report of actual unconfined compressive strength and bearing tests/results for each strata tested. Give "three-dimensional" description of each test location.
 - c. Certificates: Gradation and certification of aggregate material for Testing Laboratory review.
 - d. Qualification Documentation: Submit earthwork company documentation of experience indicating compliance with specified qualification requirements.
- B. Section 017704 - Closeout Procedures and Training: Procedures for closeout submittals.
 - 1. Project Record Documents: Accurately record final grade contours, spot elevations, and slope gradients.

1.5 QUALITY ASSURANCE

- A. Qualifications: Earthwork company specializing in performing the Work of this Section with minimum 5 years documented experience.
- B. Regulatory Requirements: Perform earthwork in accordance with applicable requirements of governing authorities having jurisdiction.
- C. Pre-Installation Meetings:
 - 1. Convene a pre-installation meeting one week prior to commencing Work of this Section.
 - 2. Require attendance of parties directly affecting Work of this Section.
 - 3. Review conditions of earthwork operations, earthwork procedures and coordination with related Work.
 - 4. Agenda:
 - a. Tour, inspect, and discuss conditions of existing soils and soil substrates.
 - b. Review dust control measures and their requirements.
 - c. Review required submittals, both completed and yet to be completed.
 - d. Review Survey and Civil sitework Drawings.
 - e. Approve proposed earthwork equipment.
 - f. Approve excess material dump location.

- g. Approve import material storage location.
- h. Review and finalize construction schedule related to earthwork and verify availability of materials, personnel, equipment, and facilities needed to make progress and avoid delays.
- i. Review required inspections, testing, certifying, and material usage accounting procedures.
- j. Review weather and forecasted weather conditions, and procedures for coping with unfavorable conditions.
- k. Review safety precautions relating to earthwork operations.
- l. Review environmental procedures.

1.6 PROJECT OR SITE CONDITIONS

A. Existing Conditions:

1. Geotechnical Data:
 - a. Soils investigation reports and data are not a part of Contract Documents.
 - b. Contractor may make additional test borings and other exploratory operations at no additional cost to U.S. Postal Service. Coordinate tests with Contracting Officer.
2. Classification of Excavations: Contractor acknowledges that Contractor has investigated project site to determine type, quantity, quality, and character of excavation work to be performed. Consider excavation as unclassified excavation, except where Rock Excavation is required. Rock Excavation criteria is as follows:
 - a. Rock Excavation: Igneous, metamorphic, or sedimentary rock that cannot be removed by rippers or other mechanical methods requiring drilling and blasting.
 - b. Rock Excavation Not Indicated in Report of Subsurface Exploration:
 - 1) Notify Contracting Officer immediately, and in writing, prior to start of Rock Excavation operations.
 - 2) Contracting Officer will visit Project Site, verify requirement for Rock Excavation, determine estimated quantity Rock Excavation required, and provide Contractor written authorization to proceed.
 - 3) Contracting Officer will verify measurements and quantities of actual Rock Excavation required and make adjustments to Contract as specified in Section 012600.
 - c. Rock excavation specified in Section 312317.
3. Existing Utilities: Contact local utility companies and make arrangements to obtain utility company location and marking service prior to start of Earthwork operations.
 - a. Locate existing underground utilities in areas of Work using "Ground Penetrating Radar (GPR)" detection. If utilities are to remain in place, provide means of support and protection during Earthwork operations.
 - 1) Pothole and locate existing underground utilities at locations to assure that no conflict with Work of this Contract will occur and required clearance is available to prevent damage to existing utilities.
 - 2) Perform potholing minimum 10 days before start of excavation or underground work.
 - b. Should uncharted, or incorrectly charted, piping or other utilities be encountered during excavation, consult utility company and Contracting Officer immediately for directions.
 - c. Coordinate with Contracting Officer and utility companies to keep existing utility services and facilities in operation.
 - d. Repair damaged utilities to satisfaction of utility company, at no additional cost to U.S. Postal Service.
 - e. Do not interrupt existing utilities serving facilities occupied and used by U.S. Postal Service or others, during occupied hours, except when permitted in writing by Contracting Officer and then only after acceptable temporary utility services have been provided and approved by Contracting Officer.
 - f. Demolish and completely remove from site existing underground utilities indicated on Drawings to be removed as specified in Section 024113. Coordinate with utility companies for shut-off of services if lines are active.

PART 2 - PRODUCTS

2.1 MATERIALS

A. Subsoil: Approved by Testing Laboratory and Contracting Officer.

1. Excavated and re-used material or select.
2. Graded.
3. Free of lumps larger than 3 inches, rocks larger than 2 inches, and debris.
4. Conforming to ASTM D 2487 CL or OL.

B. Aggregate: Approved by Testing Laboratory and Contracting Officer.

1. Coarse Aggregate: Recycled Concrete or Coarse Stone free of shale, clay, friable material and debris; graded in accordance with ASTM D 2487 Group Symbol [GW] [GP] [GM] [GC]; within the following limits:

SIEVE SIZE	PERCENT PASSING
2 inches	100
1 inch	95
3/4 inch	95 to 100
5/8 inch	75 to 100
3/8 inch	55 to 85
No. 4	35 to 60
No. 16	15 to 35
No. 40	10 to 25
No. 200	5 to 10

2. Pea Gravel: Natural Stone; washed, free of clay, shale, organic matter; graded in accordance with ASTM D 2487 Group Symbol GM or GC or requested by owner; to the following limits:
 - a. Minimum Size: 1/4 inch.
 - b. Maximum Size: 5/8 inch.
3. Fine Sand: Natural river or bank sand; washed; free of silt, clay, loam, friable or soluble materials, and organic matter; graded in accordance with ASTM D 2487 Group Symbol SW, SP, SM, or SC; within the following limits:

SIEVE SIZE	PERCENT PASSING
No. 4	100
No. 14	10 to 100
No. 50	5 to 90
No. 100	4 to 30
No. 200	0

C. Topsoil: Approved by Testing Laboratory and Contracting Officer.

1. Excavated and reused material or select.
2. Graded.
3. Free of roots, rocks larger than 1/2 inch, subsoil, debris, large weeds, and foreign matter.
4. Conforming to ASTM D 2487 Group Symbol OH.
5. Containing a minimum of 4 percent and a maximum of 25 percent inorganic matter.
6. Conforming to ASTM D 2487 Group Symbol OH or PT.
7. Limit decaying matter to 15 percent of total content by volume.

D. Filter/Drainage Fabrics:

1. Mirafi 140N.
2. Amoco Style #4546.
3. DuPont Typar 3341.

E. Soil Stabilization Materials: Specified in Section 313200.

2.2 SOURCE QUALITY CONTROL

- A. Section 014000 - Quality Requirements: Testing Laboratory services.
- B. Testing and Analysis:
 - 1. Soil: Perform in accordance with ASTM D 698, ASTM D 1557, ASTM D 2167, ASTM D 2922, and ASTM D 3017 or requested by owner.
 - 2. Aggregate: Perform in accordance with ASTM D 698, ASTM D 1557, ASTM D 2167, ASTM D 2922, ASTM D 3017, ASTM D 4318, and ASTM C 136 or requested by owner.
- C. If tests indicate materials do not meet specified requirements, change material and retest.
- D. Provide materials from same source throughout the Work.

PART 3 - EXECUTION

3.1 EXAMINATION

- A. Section 017300 - Execution: Verification of existing conditions before starting work.
- B. Verification of Conditions: Verify that field measurements, surfaces, substrates and conditions are as required, and ready to for earthwork operations to begin.
 - 1. Verify that existing site soils and soil conditions encountered are as indicated in Geotechnical Data.
 - 2. Verify quantity and type of each soil material before start of material installation.
 - 3. Backfilling:
 - a. Verify imported fill and stockpiled fill to be reused is approved.
 - b. Verify foundation perimeter drainage installation has been inspected and approved.
 - c. Verify foundation or basement walls are braced to support surcharge forces imposed by backfilling operations.
 - d. Verify areas to be backfilled are free of debris, snow, ice, or water, and ground surfaces are not frozen.
- C. Report in writing to Contracting Officer prevailing conditions that will adversely affect satisfactory execution of the Work of this Section. Do not proceed with Work until unsatisfactory conditions have been corrected.
- D. By beginning Work, Contractor accepts conditions and assumes responsibility for correcting unsuitable conditions encountered at no additional cost to the United States Postal Service.

3.2 PREPARATION

- A. Clear site as specified in Section 311000.
- B. Identify required lines, elevations, levels, contours, grades, and datum necessary to perform earthwork operations as indicated on Drawings.
- C. Examine Project Site with Contracting Officer before start of earthwork operations. Identify areas and prepare to brace or shore areas of adjacent property subject to rotation, slumping, or cave-in to prevent dislocation of adjacent soil, pavement, utilities, structures, or other items to remain.
- D. Verify that survey benchmark and intended elevations for Work are as indicated on Drawings. Short form contour designations are intended to be a continuing of the long form bench mark.

- E. Locate, identify, and protect existing utilities to remain and previously installed utilities that may be damaged by construction operations.
 - 1. Notify Contracting Officer and utility company immediately of utilities, not indicated on Drawings, encountered.
 - 2. Maintain existing utilities, active utilities, and drainage systems in operating condition.
 - 3. Comply with utility company requirements and directions of Contracting Officer to keep utilities in operation.
 - 4. Repair damage to utilities as directed by Contracting Officer.
- F. Protect plant life, lawns, fences, existing structures, sidewalks, paving and curbs from earthwork operations, excavating equipment, and vehicular traffic.
- G. Protect benchmarks, property corners, and other survey monuments from damage or displacement. Where markers are required to be removed, provide removal and reinstallation by licensed land surveyor licensed in State where project is located.
- H. Remove material encountered in grading operations that is unsuitable for backfilling, subgrade or foundation purposes as determined by Testing Laboratory and as directed by Contracting Officer. Dispose of materials off-site in an approved manner in accordance with requirements of authorities having jurisdiction.
- I. Prior to placing fill in low areas, such as previously existing creeks, ponds, or lakes, perform following procedures:
 - 1. Drain water out by gravity with ditch having flow line lower than lowest elevation in low area. If drainage cannot be performed by gravity ditch, use pumping equipment.
 - 2. After drainage of low area is complete, remove mulch, mud, debris, and other unsuitable material by using equipment and methods keeping natural soils underlying low areas dry and undisturbed.
 - 3. If proposed for fill, dry muck, mud, and other materials removed from low areas on-site by spreading in thin layers for inspection by Testing Laboratory and Contracting Officer. Place material determined by the Testing Laboratory and contracting Officer suitable for use as fill material into lowest elevation of site filling operation. Do not place under building subgrade pad or paving subgrade. If material is determined by the Testing Laboratory and Contracting Officer to be unsuitable, remove material from site.

3.3 EXCAVATION FOR FILLING AND GRADING

- A. Provide dewatering, drainage, and ground water management to control moisture of soils when performing grading operations during periods of wet weather.
- B. Shore, brace, and drain excavations to maintain excavations safe, secure, and free of water at all times.
- C. Provide protection for workers within trench areas in accordance with local, State, and Federal Occupational Safety and Health requirements and regulations.
- D. Unacceptable Fill Material for Building and Paving Areas: Excavated material containing rock or stone greater than 6 inches in largest dimension.
- E. Acceptable Fill Material:
 - 1. Rock or stone less than 6 inches in largest dimension as fill to within 24 inches of surface of proposed subgrade when mixed with suitable material.
 - 2. Rock or stone less than 2 inches in largest dimension mixed with suitable material as fill within the upper 24 inches of proposed subgrade.

3.4 FILLING AND SUBGRADE PREPARATION

- A. Fill areas to contours and elevations as indicated on Drawings with materials specified herein.
- B. Place fill in continuous lifts as specified herein.
- C. Refer to Section 312300 for filling requirements for structures, utilities, and pavements.
- D. Areas Exposed by Excavation or Stripping:
 - 1. Scarify areas exposed by excavation or stripping on which building subgrade preparations are to be performed to minimum 8 inch depth.
 - 2. Compact to minimum 95] percent optimum density in accordance with ASTM D 698 or 92 percent optimum density in accordance with ASTM D 1557 at minimum moisture content 1 percent below and maximum 3 percent above optimum moisture content.
 - 3. Proofroll to detect any areas of insufficient compaction by making minimum of 2 complete passes with fully-loaded tandem-axle dump truck, or Contracting Officer approved equivalent, in each of two perpendicular directions under supervision and direction of Testing Laboratory and Contracting Officer.
 - 4. Excavate and recompact areas failing to meet specified requirements.
- E. Fill Material Placement:
 - 1. Place in 6 inch maximum lifts compacted minimum 95 percent optimum density in accordance with ASTM D 698 or 92 percent optimum density in accordance with ASTM D 1557 at minimum moisture content of 1 percent below and maximum moisture content 3 percent above optimum moisture content.
- F. Provide material imported from off-site with CBR (California Bearing Ratio) or LBR (Limerock Bearing Ratio) value equal to or above pavement design subgrade CBR or LBR value indicated on Drawings.

3.5 MAINTENANCE OF SUBGRADE

- A. Verify finished subgrades for conformance to elevations as indicated on Drawings and for specified conditions for subgrade.
- B. Protect subgrade from excessive wheel loading during construction, including concrete trucks and dump trucks.
- C. Remove areas of finished subgrade with compaction density below specified density to depth required as directed by Testing Laboratory and Contracting Officer. Fill removed areas and compact to specified compaction density
- D. Provide surface of subgrade after compaction hard, uniform, smooth, stable, and true to grade and cross-section.

3.6 FINISH GRADING

- A. Grade areas other than paved areas and building pad areas to finish grade elevations or contours as indicated on Drawings including the following:
 - 1. Excavated areas.
 - 2. Filled and transition areas.
 - 3. Landscaped areas.
- B. Provide finish graded areas uniform and smooth, free from rocks, debris, or irregular surface changes with maximum tolerance of 0.10 feet above or below established finish subgrade elevation. Provide graded surfaces sloping uniformly between indicated elevations.
- C. Provide drainage ditches graded with uniform slope to allow drainage without ponding, minimizing potential for erosion. Refer to Section 312500 for procedures to protect slopes and control erosion.

- D. Refer to Section 313200 for soil stabilization using lime, cement, fly ash and geotextile fabric methods for subbase materials.
- E. Refer to Section 329113 for placing topsoil and fine grading in landscaped areas.

3.7 FIELD QUALITY CONTROL

- A. Section 014000 - Quality Requirements: Field testing and inspection.
- B. Excavation: Notify Testing Laboratory and Contracting Officer for visual inspection of bearing surfaces, 48 hours prior to backfilling and other subsequent Work.
- C. Site Tests - Quantity:
 - 1. Building Area Subgrade Pad:
 - a. Cut Areas: Minimum one compaction test for every 2500 square feet.
 - b. Fill Areas: Minimum one compaction test for every 2500 square feet for each 8 inch lift, measured loose.
 - 2. Areas Outside Building Area Subgrade Pad:
 - a. Cut Areas: Minimum one compaction test for every 10,000 square feet.
 - b. Fill Areas: Minimum one compaction test for every 10,000 square feet for each 8 inch lift, measured loose.
- D. Site Tests - Methods:
 - 1. Perform tests on each type of existing on-site or imported off-site material used for compacted fill.
 - a. Moisture and Density Relationship: ASTM D 698 or ASTM D 1557.
 - b. Mechanical Analysis: AASHTO T-88
 - c. Plasticity Index: ASTM D 4318
 - 1) One optimum moisture-maximum density curve for each type of soil encountered.
 - 2) Report of actual unconfined compressive strength and bearing tests/results for each strata tested. Give "three-dimensional" description of each test location.
 - 2. Perform field density tests for in-place materials in accordance to one of the following standards:
 - a. Sand-Cone Method: ASTM D 1556
 - b. Balloon Method: ASTM D 2167
 - c. Nuclear Method: ASTM D 2922 (Method B-Direct Transmission)
 - 3. Perform a CBR (California Bearing Ratio) or LBR (Limerock Bearing Ratio) test for each type of imported off-site material in areas where pavement will be placed.
- E. If tests indicate the Work does not meet specified requirements, remove Work, replace, compact, and retest at no additional cost to United States Postal Service.

3.8 PROTECTION

- A. Protect building subgrade pad and building related earthwork from damage by construction operations and erosion.
- B. Prohibit vehicles from entering building subgrade pad area. Vehicles not permitted.
- C. Scarify surface, reshape, and compact areas damaged by construction operations or weather erosion.

END OF SECTION

USPS MPF Specification Last Revised: 10/1/2022

312000 - 8

SECTION 312300
EXCAVATION AND FILL

PART 1 - GENERAL

1.1 SUMMARY

- A. Section Includes:
 - 1. Excavating and backfilling for structures, utilities, and pavement.
 - 2. Pipe bedding.
 - 3. Compacting fill materials.
 - 4. Borings and casings under roads.

- B. Related Documents: The Contract Documents, as defined in Section 011000 - Summary of Work, apply to the Work of this Section. Additional requirements and information necessary to complete the Work of this Section may be found in other Documents.

- C. Related Sections:
 - 1. Section 312000 - Earth Moving: Cutting, filling, and grading for proposed site improvements.
 - 2. Section 312317 - Rock Excavation: Removal of rock during excavation.
 - 3. Section 313200 - Soil Stabilization: Lime, cement, fly ash, and geotextile subgrade stabilizers.

1.2 REFERENCES

- A. American Society for Testing and Materials (ASTM):
 - 1. ASTM D698 - Test Method for Laboratory Compaction Characteristics of Soil Using Standard Effort.
 - 2. ASTM D1557 - Test Method for Laboratory Compaction Characteristics of Soil Using Modified Effort.

- B. American Association of State Highway and Transportation Officials (AASHTO):
 - 1. AASHTO T 180 - Moisture-Density relations of Soils Using a 10 Pound Rammer and an 18 Inch Drop.

- C. American Water Works Association (AWWA):
 - 1. AWWA C 200 - Steel Water Pipe, 6 Inch and Larger.
 - 2. AWWA C 206 - Field Welding of Steel Water Pipe.

- D. National Fire Protection Association (NFPA):
 - 1. NFPA 70 - National Electric code.

1.3 DEFINITIONS

- A. Building Area Subgrade Pad: Portion of site directly beneath and within a line 10 feet beyond building and appurtenances including limits of any future building expansion areas indicated on Drawings.

1.4 SUBMITTALS

- A. Section 013300 - Submittal Procedures: Procedures for submittals.
 - 1. Shop Drawings:

- a. Submit drawings or details indicating proposed alternate earthwork procedures or proposed procedures not indicated in Contract Documents.
 - b. Shop Drawings or details pertaining to Site Utilities are not required unless required by regulatory authorities or unless use of materials, methods, equipment, or procedures are contrary to Drawings or these specifications are proposed. Do not perform work until required shop drawings have been approved by Contracting Officer.
2. Assurance/Control Submittals:
- a. Material Source: Submit name of imported materials suppliers. Provide materials from same source throughout the work. Change of source requires Contracting Officer approval.
 - b. Test Reports: Submit the following reports directly to Contracting Officer from Testing Laboratory, with copy to Contractor:
 - 1) Test reports on borrow material.
 - 2) Verification of each footing subgrade.
 - 3) Field density test reports.
 - 4) Optimum moisture-maximum density curve for each type of soil encountered.
 - 5) Report of actual unconfined compressive strength and bearing tests/results for each strata tested. Give "three-dimensional" description of each test location.
 - c. Certificates: Gradation and certification of aggregate material for Testing Laboratory review.
 - d. Qualification Documentation: Submit earthwork company documentation of experience indicating compliance with specified qualification requirements.
- B. Section 017704 - Closeout Procedures and Training: Procedures for closeout submittals.
- 1. Project Record Documents: Accurately record the following.
 - a. Spot elevations for building area subgrade pad.
 - b. Location of existing utilities remaining, re-routed utilities, new utilities by horizontal dimensions, elevations or inverts, and slope gradients.

1.5 QUALITY ASSURANCE

- A. Qualifications: Earthwork company specializing in performing the Work of this Section with minimum 5 years documented experience.
- B. Regulatory Requirements: Perform earthwork in accordance with applicable requirements of governing authorities having jurisdiction.

1.6 PROJECT CONDITIONS OR SITE CONDITIONS

- A. Existing Conditions: Requirements specified in Section 312000.
- B. Existing Utilities: Requirements specified in Section 312000.

PART 2 - PRODUCTS

2.1 MATERIALS

- A. Stockpiled on-site fill and backfill material specified in Section 312000, tested by Testing Laboratory and approved by Contracting Officer.
- B. Imported off-site fill and backfill material specified in Section 312000, tested by Testing Laboratory and approved by Contracting Officer.

- C. Pipe Bedding Material: Processed sand and gravel free from clay lumps, organic, or other deleterious material complying with the following gradation requirements:

<u>SIEVE SIZE</u>	<u>PERCENT PASSING</u>
1 Inch	100
3/4 Inch.....	90 to 100
3/8 Inch.....	20 to 55
No. 4.....	0 to 10
No. 8.....	0 to 5

- D. Steel Casing Pipe: AWWA C 200, minimum grade B; size and wall thickness as indicated on Drawings.
- E. Stabilization Fabrics and Geogrids:
1. Mirafi 500X or 600X.
 2. Amoco Style #2002 Woven.
 3. Reemay Typar 3401 and 3601.
 4. Trevira S1114 and S1120.
 5. Tensar 1100 and 1200.
- F. Filter/Drainage Fabrics:
1. Mirafi 140 N.
 2. Amoco Style #4546.
 3. Reemay Typar 3341.
 4. Carthage Mills, Carthage 6%.

PART 3 - EXECUTION

3.1 EXAMINATION

- A. Section 017300 - Execution: Verification of existing conditions before starting work.
- B. Verification of Conditions: Verify that field measurements, surfaces, and conditions are as required, and ready to receive Work.
- C. Report in writing to Contracting Officer prevailing conditions that will adversely affect satisfactory execution of the Work of this Section. Do not proceed with Work until unsatisfactory conditions have been corrected.
- D. By beginning Work, Contractor accepts conditions and assumes responsibility for correcting unsuitable conditions encountered at no additional cost to United States Postal Service.

3.2 PREPARATION

- A. Identify required lines, elevations, levels, contours, grades, and datum necessary to perform earthwork operations as indicated on Drawings.
- B. Verify that survey benchmark and intended elevations for the Work are as indicated on Drawings.
- C. Locate, identify, and protect existing utilities to remain and previously installed utilities that may be damaged by construction operations.
1. The routing of existing underground utilities, conduit and piping shall be located using "Ground Penetrating Radar (GPR)" detection.
 2. Notify Contracting Officer, municipality, and utility company immediately of utilities, not indicated on Drawings, encountered.
 3. Maintain existing utilities, active utilities, and drainage systems in operating condition.

4. Comply with utility company requirements and directions of Construction Manager to keep utilities in operation.
 5. Repair damage to utilities as directed by Contracting Officer.
- D. Protect plant life, lawns, fences, existing structures, sidewalks, paving and curbs from earthwork operations, excavating equipment, and vehicular traffic.
- E. Protect bench marks, property corners, and other survey monuments from damage or displacement. Where markers are required to be removed, provide removal and reinstallation by licensed land surveyor licensed in State where project is located.
- F. Overexcavate areas of building subgrade found consisting of unsuitable materials as determined by Testing Laboratory and Contracting Officer. Prepare, fill with suitable material, and compact as specified. Stabilize areas as specified in Section 313200.

3.3 EXCAVATION

- A. Excavation for filling and grading specified in Section 312000.
- B. Rock excavation specified in Section 312317.
- C. Excavation for Structures:
1. Excavate subbase for building foundations, slabs-on-grade and site structures to width and depth indicated on Drawings.
 - a. Cut excavation banks vertically.
 - b. Remove rocks, loose soil, and debris from bottom of excavation.
 - c. Overexcavate wet or unsuitable soil from bottom of excavation.
 - d. Provide stable base for concrete reinforcing installation and concrete placement.
 - e. Hand trim to indicated lines and grades just prior to concrete reinforcing installation.
 2. Provide protection for workers within trench areas in accordance with local, state, and national Occupational Safety and Health requirements and regulations.
 - a. Trenches minimum 4 feet in depth.
 3. During excavation, stockpile materials suitable for backfilling away from excavation to prevent overloading, slides, or cave-ins.
 4. Remove material encountered in excavating operations that is unsuitable for backfilling, subgrade or foundation purposes as determined by Testing Laboratory and Contracting Officer. Dispose of materials off-site in an approved manner in accordance with requirements of authorities having jurisdiction.
 5. Prevent surface water from flowing into excavations by temporary grading or other approved methods.
 - a. Do not allow water to accumulate in excavations.
 - b. Remove accumulated water in excavations.
 - c. Provide and maintain pumps, well points, sumps, suction and discharge lines, and other dewatering system components required to remove water from excavations.
- D. Excavation for Utilities:
1. Excavate trench width and depth required for laying pipe, conduit, or cable. Cut trench banks vertical. Remove stones from bottom of trench as required to avoid point-bearing. Over excavate wet or unstable soil, if encountered, from trench bottom as required to provide suitable base for continuous and uniform bedding.
 2. During excavation, stockpile materials suitable for backfilling away from trench bank to prevent overloading, slides, or cave-ins.
 3. Remove material encountered in trenching operations that is unsuitable for backfilling, subgrade or foundation purposes as determined by Testing Laboratory and Contracting Officer. Dispose of materials off-site in an approved manner in accordance with requirements of authorities having jurisdiction.

4. Prevent surface water from flowing into trenches or other excavations by temporary grading or other approved methods.
 - a. Do not allow water to accumulate in excavations.
 - b. Remove accumulated water in excavations.
 - c. Provide and maintain pumps, well points, sumps, suction and discharge lines and other dewatering system components required to remove water from excavations.
 5. Open cut excavation using trenching machine or backhoe. Do not use dirt clods for backfill created by use of machines other than ladder or wheel-type trenching machines.
 6. Grade trench bottom to provide uniform bearing and support for each section of pipe on bedding material along entire trench length, except where necessary to excavate for bell holes, proper sealing of pipe joints, or other required connections. Dig bell holes and depressions for joints after trench bottom has been graded. Do not excavate trench deeper, longer, or wider than required to make proper joint connection.
 7. Excavate trench width below the top of pipe minimum 300 mm wide and maximum 460 mm wider than outside surface of pipe or conduit installed to elevations and grades indicated on Drawings. Excavate trench width for other pipe, conduit, or cable to least practical width allowing for proper compaction of trench backfill.
 8. Excavate trench depth measured from finished grade or paved surface to the following requirements or applicable codes and ordinances:
 - a. Water Mains: 30 inches to top of pipe barrel or 6 inches below frost line established by local building official, whichever is deeper.
 - b. Sanitary Sewer: Elevations, and grades indicated on Drawings.
 - c. Storm Sewer: Depths, elevations, and grades indicated on Drawings.
 - d. Electrical Conduits: 24 inches minimum to top of conduit or as required by NFPA 70, or local utility company requirements, whichever is deeper.
 - e. TV Conduits: 18 inches minimum to top of conduit or as required by local utility company, whichever is deeper.
 - f. Telephone Conduits: 18 inches minimum to top of conduit, or as required by local utility company, whichever is deeper.
 - g. Gas Mains and Service: 30 inches minimum to top of pipe, or as required by local utility company, whichever is deeper.
 9. Provide shoring, sheeting, and bracing, as required, in trenches and other excavations where protection of construction personnel is required. Sheeting may be removed after sufficient backfilling to protect against damaging or injurious caving.
- E. Excavation for Pavement:
1. Excavate roadway and pavement areas to line and grade indicated on Drawings.
 2. Stockpile excavated material suitable for backfilling on-site.
 3. Remove excavated materials not required or not suitable for backfill from site.
 4. Overexcavate areas of pavement subgrade found to contain unsuitable material. Prepare, fill with suitable material, and compact as specified. Stabilize areas as specified in Section 313200.

3.4 PIPE BEDDING

- A. Excavate trenches, for pipe or conduit installed to elevations indicated on Drawings, 4 inches below bottom of pipe and to width as specified. Place 4 inches of bedding material, compact in bottom of trench, and shape to conform to lower portion of pipe barrel. After pipe installation, backfill and compact to top of trench.
- B. Place geotextile fabric as indicated on Drawings.

3.5 BACKFILLING AND SUBGRADE PREPARATION

- A. Backfilling:
 1. Verify that imported off-site fill and stockpiled on-site fill is tested and approved.

- 2. Verify that foundation perimeter drainage installation is inspected and approved.
 - 3. Verify that foundation or below grade structure walls are braced to support surcharge forces imposed by backfilling operations.
 - 4. Verify that backfill areas are free of debris, snow, ice, or water, and that ground surfaces are not frozen.
- B. Prepare building area subgrade pad in accordance with foundation subsurface preparation information indicated on Drawings and specified herein. Do not use rock larger than 6 inches for building subgrade fill.
- C. Areas Exposed by Excavation or Stripping:
- 1. Scarify areas exposed by excavation or stripping on which building subgrade preparations are to be performed to minimum 8 inch depth.
 - 2. Compact to minimum 95 percent optimum density in accordance with ASTM D1557 (Modified Proctor) at minimum moisture content 1 percent below and maximum 3 percent above optimum moisture content.
 - 3. Proofroll to detect any areas of insufficient compaction by making minimum of 2 complete passes with fully-loaded tandem-axle dump truck, or Contracting Officer approved equivalent, in each of two perpendicular directions under supervision and direction of Contracting Officer.
 - 4. Excavate and recompact areas failing to meet specified requirements.
- D. Fill Material Placement:
- 1. Place in 6 inch maximum lifts compacted minimum 95 percent optimum density in accordance with ASTM D1557 (Modified Proctor) at minimum moisture content of 1 percent below and maximum moisture content 3 percent above optimum moisture content.
 - 2. Maximum allowable values for plasticity index (PI) and liquid limit (LL) of suitable fill materials to be used as fill in the specified areas, unless indicated otherwise on Drawings:

<u>LOCATION</u>	<u>PI</u>	<u>LL</u>
Building area, below upper 4 feet of proposed subgrade elevation	30	40
Building area, upper 4 feet of proposed subgrade elevation.....	20	30
Paving area, below upper 4 feet of proposed subgrade elevation	30	40
Paving area, upper 4 feet of proposed subgrade elevation	20	30

- E. Provide material imported from off-site with CBR (California Bearing Ratio) or LBR (Limerock Bearing Ratio) value equal to or above pavement design subgrade CBR or LBR value indicated on Drawings.

3.6 MAINTENANCE OF SUBGRADE

- A. Verify finished subgrades for elevations indicated on Drawings and specified conditions for construction above subgrade.
- B. Protect subgrade from excessive wheel loading during construction, including concrete trucks and dump trucks.
- C. Remove areas of finished subgrade found to have insufficient compaction density. Replace in a manner that will comply with compaction requirements as directed by Contracting Officer. Provide hard, uniform, smooth, stable surface, true to grade and cross-section after completion of compaction.

3.7 BORINGS AND CASINGS UNDER ROADS

- A. Install street, road, or highway crossings for utility mains by jacking and boring method in accordance with requirements of governing authorities having jurisdiction.

- B. Locate approach pits and trenches within right- of-way of street, road, highway, or railroad distance from paving permitting traffic to pass without interference. Tamp backfill for approach pits and trenches within right- of-way in layers not greater than 6 inches thick for entire length and depth of trench or pit. Compact backfill to 95 percent of maximum density obtained at optimum moisture as determined by AASHTO T 180, Method A (Modified Proctor). Mechanical tampers may be used after cover of 6 inches has been obtained over top of pipe barrel.
- C. Use commercial type boring rig providing hole bored to proper alignment and grade within 2 inches of same diameter as largest outside joint diameter of pipe installed. Install pipe in hole immediately after bore has been made, and in no instance shall hole be left open while unattended.
- D. Clean and prime interior and exterior of casing pipe; apply two coats of asphalt in accordance with requirements of governing authorities having jurisdiction.
- E. Butt weld steel casing. Weld using full penetration single butt-welds in accordance with AWWA C 206.
- F. Install casing and utility pipe with end seals, vent pipe, and other special equipment in accordance with requirements of governing authorities having jurisdiction.
- G. Paving Damage Caused by Contractor Construction Operations:
 - 1. Repair paving where cracks occur on either side of line where pipe was installed by removing damaged paving between cracks, sawcutting paving in straight line at a point sufficiently beyond location of cracks for repair and placing new paving to match existing in areas where paving removed.
 - 2. Make repairs to the satisfaction of paving owner.
 - 3. Make repairs at no additional cost to United States Postal Service within one year from Date of Substantial Completion.

3.8 FIELD QUALITY CONTROL

- A. Section 014000 - Quality Requirements: Field testing and inspection.
- B. Excavation: Notify Testing Laboratory and Contracting Officer for visual inspection of bearing surfaces, 48 hours prior to backfilling and other subsequent Work.
- C. Site Tests:
 - 1. Specified in Section 312000.
 - 2. Tests for Building Area Subgrade Pad:
 - a. Cut Areas: Minimum one compaction test for every 2500 square feet.
 - b. Fill Areas: Minimum one compaction test for every 2500 square feet for each 8 inch lift measured loose.
 - 3. Tests for areas outside building area subgrade pad specified in Section 312000.
- D. If tests indicate the Work does not meet specified requirements, remove Work, replace, compact and retest at no additional cost to United States Postal Service.

3.9 PROTECTION

- A. Protect building subgrade pad and building related earthwork from damage by construction operations and erosion.
- B. Prohibit vehicles from entering building subgrade pad area. Vehicles not permitted.
- C. Scarify surface, reshape, and compact areas damaged by construction operations or weather erosion.

END OF SECTION

USPS MPF Specification Last Revised: 10/1/2022

312300 - 8

SECTION 312500

EROSION AND SEDIMENTATION CONTROLS

PART 1 - GENERAL

1.1 SUMMARY

- A. Section Includes:
 - 1. Temporary and permanent erosion control systems.
 - 2. Slope protection systems.
- B. Related Documents: The Contract Documents, as defined in Section 011000 - Summary of Work, apply to the Work of this Section. Additional requirements and information necessary to complete the Work of this Section may be found in other Documents.
- C. Related Sections:
 - 1. Section 313200 - Soil Stabilization: Lime, cement, fly ash, and geotextile subgrade stabilizers.

1.2 SUBMITTALS

- A. Section 013300 - Submittal Procedures: Procedures for Quality Assurance/Control submittals.
 - 1. Material Source: Submit name of material suppliers.
 - 2. Provide materials from same source throughout Work. Change of source requires Contracting Officer approval.

1.3 PROJECT CONDITIONS OR SITE CONDITIONS

- A. Environmental Requirements: Protect adjacent properties and water resources from erosion and sediment damage throughout Work.

PART 2 - PRODUCTS

2.1 MATERIALS

- A. Quick Growing Grasses: Wheat, rye, or oats.
- B. Straw Bales: Free of weed seed.
- C. Fencing for Siltation Control: Indicated on Drawings.
- D. Erosion Control Blankets and/or Erosion Control Geotextiles.
- E. Bale Stakes:
 - 1. Minimum 4 feet length.
 - 2. Two No. 4 steel reinforcing bars or,
 - 3. Two steel pickets or,
 - 4. Two 2 x 2 inch hardwood stakes driven 18 inches to 24 inches into ground.
- F. Temporary Mulches: Loose straw, netting, wood cellulose, or agricultural silage free of seed.

- G. Metal Fence Stakes: Minimum 8 foot length.

PART 3 - EXECUTION

3.1 EXAMINATION

- A. Section 017300 - Execution: Verification of existing conditions before starting Work.
- B. Verification of Conditions: Verify that field measurements, surfaces, substrates and conditions are as required, and ready to receive Work.
- C. Report in writing to Contracting Officer prevailing conditions that will adversely affect satisfactory execution of the Work of this Section. Do not proceed with Work until unsatisfactory conditions have been corrected.
- D. By beginning Work, Contractor accepts conditions and assumes responsibility for correcting unsuitable conditions encountered at no additional cost to U.S. Postal Service.

3.2 PREPARATION

- A. Review Stormwater Pollution Prevention Plan SWP³.
- B. Notify Contracting Officer of deficiencies or changes in Stormwater Pollution Prevention Plan SWP³ required by current site conditions. Revisions of plan will be made as determined by Contracting Officer.

3.3 EROSION CONTROL AND SLOPE PROTECTION IMPLEMENTATION

- A. Contracting Officer may direct Contractor to limit surface area of erodible earth material exposed by clearing and grubbing, excavation, borrow and embankment operations and may direct Contractor to provide immediate permanent or temporary pollution control measures.
- B. Provide permanent erosion control measures at earliest practical time to minimize requirement for temporary erosion controls. Permanently seed and mulch cut slopes as excavation proceeds.
- C. Maintain temporary erosion control systems installed by Contractor as directed by Contracting Officer to control siltation at all times throughout Work. Provide maintenance or additional Work directed by Contracting Officer within 48 hours of notification by Contracting Officer.
- D. Apply soil stabilization as specified in Section 313200 or seed slopes that may be easily eroded with wheat, rye, or oat grasses.

END OF SECTION

USPS MPF Specification Last Revised: 10/1/2022

SECTION 321216

ASPHALT PAVING

PART 1 - GENERAL

1.1 SUMMARY

- A. Section Includes:
 - 1. Bituminous concrete paving.
 - 2. Surface course.
 - 3. Binder course.
 - 4. Paving base course.
- B. Related Documents: The Contract Documents, as defined in Section 011000 - Summary of Work, apply to the Work of this Section. Additional requirements and information necessary to complete the Work of this Section may be found in other Documents.
- C. Related Sections:
 - 1. Section 312000 - Earth Moving: Earthwork for Pavement.
 - 2. Section 321313 - Concrete Paving: Concrete paving, curbs and sidewalks.
 - 3. Section 321723 - Pavement Markings: Painted pavement markings.

1.2 REFERENCES

- A. Asphalt Institute (AI):
 - 1. AI MS-2 - Mix Design Methods for Asphalt Concrete and Other Hot Mix Types.
 - 2. AI MS-3 - Asphalt Plant Manual.
 - 3. AI MS-8 - Asphalt Paving Manual.
 - 4. AI MS-19 - Basic Asphalt Emulsion Manual.
- B. American Society for Testing and Materials (ASTM):
 - 1. ASTM D 242 - Specification for Mineral Fiber for Bituminous Paving Mixtures.
 - 2. ASTM D 698 - Test Methods for Moisture-Density Relations of Soils and Soil-Aggregate Mixtures, Using 5.5 Pound Rammer and 12 inch Drop.
 - 3. ASTM D 1188 - Method for Bulk Specific Gravity and Density of Compacted Bituminous Mixtures Using Paraffin-Coated Specimens.
 - 4. ASTM D 1557 - Test Methods for Moisture-Density Relations of Soils and Soil-Aggregate Mixtures Using 10 Pound Rammer and 18 inch Drop.
 - 5. ASTM D 1560 - Test Method for Resistance to Deformation and Cohesion of Bituminous Mixtures by Means of Hveem Apparatus.
 - 6. ASTM D 2397 - Specification for Cationic Emulsified Asphalt.
 - 7. ASTM D 2399 - Practice for Selection of Cutback Asphalt.
 - 8. ASTM D 2726 - Test Method for Bulk Specific Gravity and Density of Nonabsorbative Compacted Bituminous Mixtures.
 - 9. ASTM D 3381 - Specification for Viscosity-Graded Asphalt Cement for Use in Pavement Construction.
 - 10. ASTM D 3549 - Test Method for Thickness or Height of Compacted Bituminous Paving Mixture Specimens.
 - 11. ASTM D 4318 - Test Method for Liquid Limit, Plastic Limit, and Plasticity Index of Soils.
- C. American Association of State Highway and Transportation Officials (AASHTO):
 - 1. AASHTO T 88 - Particle Size Analysis of Soils.

1.3 SYSTEM DESCRIPTION

- A. Design Requirements: Provide asphalt-aggregate mixture as recommended by local or state paving authorities to suit project conditions. Use locally available materials and gradations which meet standard state highway specifications and exhibit satisfactory records of previous installations.

1.4 SUBMITTALS

- A. Section 013300 - Submittal Procedures: Procedures for submittals.
 - 1. Assurance/Control Submittals:
 - a. Design Data:
 - 1) Submit design mix following format indicated Asphalt Institute Manual MS-2, Marshall Stability Method; including type/name of mix, gradation analysis, grade of asphalt cement used, Marshall Stability (pounds), flow, effective asphalt content (percent), and direct references to applicable state highway department specification sections for each material.
 - 2) Provide design mixture listed in current edition of applicable state highway department specifications.
 - 3) Use mix designs prepared within 3 years maximum.
 - 4) Provide documentation of state highway limitations, if any, on use of recycled content materials.
 - b. Certificates: Submit materials certificate to Testing Laboratory signed by material supplier and Contractor, certifying that materials comply with, or exceed, the requirements specified herein.
 - c. Qualification Documentation: Paving installer documentation of experience indicating compliance with specified qualification requirements.

1.5 QUALITY ASSURANCE

- A. Perform Work in accordance with AI MS-8
- B. Installer Qualifications: Company specializing in performing the Work of this Section with minimum 5 years documented experience.
- C. Regulatory Requirements:
 - 1. Conform to applicable requirements for paving work on public property.
 - 2. Maintain access for vehicular and pedestrian traffic as required for other construction activities. Use temporary striping, flagmen, barricades, warning signs, and warning lights as required.

1.6 PROJECT CONDITIONS OR SITE CONDITIONS

- A. Jobsite Requirements:
 - 1. Apply prime and tack coats when ambient temperature is above 40 degrees F, and when temperature has been above 35 degrees F for 12 hours immediately prior to application. Do not apply when base is wet, contains excess moisture, or during rain.
 - 2. Construct bituminous concrete paving when atmospheric temperature is above 40 degrees F.

1.7 ENVIRONMENTAL REQUIREMENTS

- A. Resource Management:

1. Recycled Content: Provide aggregate fabricated from a minimum of 30% recycled rubble or concrete. Provide asphalt cement fabricated from recycled content asphalt.

PART 2 - PRODUCTS

2.1 MATERIALS

- A. Base Course: As indicated on Drawings, complying with applicable state highway specifications regarding source, quality, gradation, liquid limit, plasticity index and mix proportioning.
 1. Unless otherwise specified in applicable state highway specifications, provide base course aggregate fabricated from minimum 30 percent recycled rubble or concrete.
- B. Asphalt Cement: Fabricated from minimum 15 percent recycled asphalt and complying with ASTM D 3381; Table 2 AC-10, AC-20, or AC-30, viscosity grade, depending on local mean annual air temperature as indicated below:

<u>TEMPERATURE CONDITION</u>	<u>ASPHALT GRADES</u>
Cold, mean annual air temperature at 45 degrees F or lower	AC-10, 85/100 pen.
Warm, mean annual air temperature between 45 degrees F and 75 degrees F	AC-20, 60/70 pen.
Hot, mean annual air temperature at 75 degrees F or higher.....	AC-30

- C. Prime Coat: A medium curing cut-back asphalt or an asphalt penetrating prime coat consisting of either ASTM D 2397 or ASTM D 2399, MC- 30 or SS-1h.
- D. Tack Coat: Emulsified asphalt; ASTM D 2397 or ASTM D 2399, SS-1h, CSS-1, or CSS-1h, diluted with one part water to one part emulsified asphalt.
- E. Mineral Filler: Rock or slag dust, hydraulic cement, or other inert material complying with AASHTO M-17/ASTM D 242, if recommended by applicable state highway department standards.
- F. Asphalt-Aggregate Mixture: Unless otherwise indicated on Drawings, the Design Mix shall have a minimum stability based on a 50-blow Marshall complying with ASTM D 1559 of 1000 pounds with a flow between 8 and 16. The Design Mix shall be within sieve analysis and bitumen ranges below:

SIEVE ANALYSIS OF MIX

<u>Square Sieve</u>	<u>Total Percent Passing</u>	<u>Percent Tolerance</u>
1/2 inch	80 - 100.....	5
3/8 inch	65 - 93.....	4
No. 8	0 - 55.....	4
No. 50	2 - 27.....	2
No. 200	0 - 10.....	2

Percent Bitumen by Weight of Total Mix: 5.0 - 8.5.
 Percent Air Voids: 3-6.
 Percent Aggregate Voids Filled with Asphalt Cement: 70 - 82.
 Allowable Variance of Percent Bitumen by Weight of Total Mix: 0.4.

2.2 EQUIPMENT

- A. Maintain equipment in satisfactory operating condition and correct breakdowns in a manner that will not delay or be detrimental to progress of paving operations.

PART 3 - EXECUTION

3.1 EXAMINATION

- A. Section 017300 - Execution: Verification of existing conditions before starting work.
- B. Verification of Conditions: Verify that field measurements, surfaces, substrates and conditions are as required, and ready to for earthwork operations to begin.
 - 1. Verify gradients and elevations of base are correct, and base is dry.
- C. Report in writing to Contracting Officer prevailing conditions that will adversely affect satisfactory execution of the Work of this Section. Do not proceed with Work until unsatisfactory conditions have been corrected.
- D. By beginning Work, Contractor accepts conditions and assumes responsibility for correcting unsuitable conditions encountered at no additional cost to the United States Postal Service.

3.2 BASE COURSE PLACEMENT

- A. Perform base course construction in a manner that will drain surface properly at all times and at the same time prevent runoff from adjacent areas from draining onto base course construction.
- B. Compact base material to not less than 98 percent of optimum density as determined by ASTM D 698 or 95 percent of optimum density, as determined by ASTM D 1557, unless otherwise indicated on the Drawings.
- C. Granular Base: Construct to thickness indicated on Drawings. Apply in lifts or layers not exceeding 6 inches, measured loose.
- D. Sand/Shell Base: Construct to thickness indicated on Drawings. Apply in lifts or layers not exceeding 4 inches, measured loose.
- E. Asphalt Institute Type IV Mix for Full Depth Asphalt Base: Construct to thickness indicated on Drawings in lifts or layers not exceeding 3 inches, measured loose.
- F. Asphalt Institute Type VI, VII, or VIII Mixes for Hot-Mix Sand Asphalt Bases: Construct to thickness indicated on Drawings. Apply in lifts or layers not exceeding 3 inches, measured loose.
- G. Soil Cement Stabilized Base: Construct to thickness and strength as indicated on Drawings and in accordance with applicable state highway specifications. If not indicated on the Drawings, the minimum compressive strength shall be 500 pounds per square inch, tested at 28 days.

3.3 APPLICATIONS

- A. Prime Coat:
 - 1. Apply bituminous prime coat to all base material surfaces where bituminous concrete paving will be constructed.
 - 2. Apply bituminous prime coat in accordance with applicable state highway specifications.
 - 3. Apply at minimum rate of 0.25 gallon per square yard over compacted base material. Apply to penetrate and seal, but not flood surface.
 - 4. Make necessary precautions to protect adjacent areas from overspray.
 - 5. Cure and dry as long as necessary to attain penetration of compacted base and evaporation of volatile substances.

B. Tack Coat:

1. Apply to contact surfaces of previously constructed bituminous concrete base courses or portland cement concrete and surfaces abutting or projecting into bituminous concrete or into bituminous concrete pavement.
2. Apply tack coat to bituminous concrete base course or sand asphalt base course. Apply emulsified asphalt tack coat between each lift or layer of full depth bituminous concrete and sand asphalt bases and on surface of all such bases where bituminous concrete paving will be constructed.
3. Apply emulsified asphalt tack coat in accordance with applicable state highway specifications.
4. Apply at minimum rate of 0.05 gallon per square yard of surface.
5. Allow to dry until at proper condition to receive paving.

3.4 BITUMINOUS CONCRETE PLACEMENT

- A. Place bituminous concrete mixture on completed compacted subgrade surface, spread, and strike off. Spread mixture at following minimum temperatures:
 1. When ambient temperature is between 40 degrees F and 50 degrees F, mixture temperature equal to 285 degrees F.
 2. When ambient temperature is between 50 degrees F and 60 degrees F, mixture temperature equal to 280 degrees F.
 3. When ambient temperature is higher than 60 degrees F, mixture temperature equal to 275 degrees F.
- B. Whenever possible, all pavement shall be spread by a finishing machine; however, inaccessible or irregular areas may be placed by hand methods. The hot mixture shall be spread uniformly to the required depth with hot shovels and rakes. After spreading, the hot mixture shall be carefully smoothed to remove all segregated course aggregate and rake marks. Rakes and lutes used for hand spreading shall be of the type designed for use on asphalt mixtures. Loads shall not be dumped faster that they can be properly spread. Workers shall not stand on the loose mixture while spreading.
- C. Paving Machine Placement: Apply successive lifts of bituminous concrete in transverse directions with the surface course placed in the direction of surface-water flow. Place in typical strips not less than 10 feet wide.
- D. Joints: Make joints between old and new pavements, or between successive days and work in a manner that will provide a continuous bond between adjoining work. Construction joints shall have same texture, density, and smoothness as other sections of bituminous concrete course. Clean contact surfaces of all joints and apply tack coat.

3.5 ROLLING AND COMPACTION

- A. The mixture, after being spread, shall be thoroughly compacted by rolling as soon as it will bear the weight of the rollers without undue displacement. The number, weight, and types of rollers and sequences of rolling operations shall be such that the required density and surface are consistently attained while the mixture is in a workable condition.
- B. Compact mixture with hot hand tampers or vibrating plate compactors in areas inaccessible to rollers.
- C. Breakdown Rolling: Accomplish breakdown or initial rolling immediately following rolling of joints and outside edge. Check surface after breakdown rolling, and repair displaced areas by loosening and filling with hot material.
- D. Second Rolling: Follow breakdown rolling as soon as possible, while mixture is hot. Continue second rolling until mixture has been thoroughly compacted.

- E. Finish Rolling: Perform finish rolling while mixture is still warm enough for removal of roller marks. Continue rolling until roller marks are eliminated and course has attained maximum density.
- F. Patching: Remove and replace paving areas mixed with foreign materials and defective areas. Cut out such areas and fill with fresh, hot bituminous concrete. Compact by rolling to maximum surface density and smoothness.
- G. Protection: After final rolling, do not permit vehicular traffic on pavement until it has cooled and hardened. Erect barricades to protect paving from traffic until mixture has cooled enough not to become marked.

3.6 CONSTRUCTION

- A. Site Tolerances:
 - 1. Paving Surface Smoothness: Maximum allowable 10 foot straightedge tolerance for smoothness.
 - a. Base Course Surface: 1/4 inch.
 - b. Wearing Surface Course: 3/16 inch.

3.7 FIELD QUALITY CONTROL

- A. Section 014000 - Quality Requirements: Field inspection and testing procedures
- B. Site Tests:
 - 1. Paving Base Course: Perform testing of in-place base courses for compliance with requirements for thickness, compaction, density, and tolerance.
 - a. Moisture/Density Test: ASTM D 698 or ASTM D 1557.
 - b. Mechanical Analysis Test: AASHTO T-88.
 - c. Plasticity Index Test: ASTM D 4318.
 - d. Base Material Thickness Test: Minimum one test for every 20,000 square feet.
 - e. Base Material Compaction Test: Minimum one test for every 20,000 square feet.
 - f. Field Density Tests: Perform testing of in-place base courses for compliance with requirements for density using one of the following methods:
 - 1) Sand-cone Method: ASTM D 1556.
 - 2) Balloon Method: ASTM D 2167.
 - 3) Nuclear Method: ASTM D 2922, Method B (Direct Transmission).
 - g. Test each source of base material for compliance with applicable state highway specifications.
 - 2. Asphalt Concrete Paving: Perform testing of in-place asphalt concrete paving courses for compliance with requirements for thickness, compaction, and surface smoothness.
 - a. Thickness: ASTM D 3549; Thickness shall not be less than thickness specified on Drawings.
 - b. Surface Smoothness: Testing shall be performed on the finished surface of each asphalt paving course using 10 foot straightedge applied parallel with, and at right angles to centerline of paved areas. Smoothness shall not be less than tolerances specified herein.
 - 3. Compaction: Field density test for in place materials shall be performed by examination of field cores in accordance with one of the following standards:
 - a. Bulk Specific Gravity of Paraffin-Coated Specimens: ASTM D 1188, minimum one core per 20,000 square feet.
 - 1) Standard Duty Areas: Minimum 3 cores.
 - 2) Heavy Duty Areas: Minimum 3 cores.
 - b. Bulk Specific Gravity Using Saturated Surface-Dry Specimens: ASTM D 2726, minimum one core per 20,000 square feet.
 - 1) Standard Duty Areas: Minimum 3 cores.
 - 2) Heavy Duty Areas: Minimum 3 cores.

END OF SECTION

USPS MPF Specification Last Revised: 10/1/2022

321216 - 7

SECTION 321313
CONCRETE PAVING

PART 1 - GENERAL

1.1 SUMMARY

- A. Section Includes:
 - 1. Concrete Pavement
 - 2. Concrete walks and terraces.
 - 3. Concrete curbs, and curb and gutters.

- B. Related Documents: The Contract Documents, as defined in Section 011000 - Summary of Work, apply to the Work of this Section. Additional requirements and information necessary to complete the Work of this Section may be found in other documents.

- C. Related Sections:
 - 1. Section 312000 - Earth Moving: Earthwork for pavement.
 - 2. Section 321216 - Asphalt Paving.
 - 3. Section 033000 - Cast-In-Place Concrete: Concrete requirements for pavement.

1.2 REFERENCES

- A. American Concrete Institute (ACI):
 - 1. ACI 301 - Specifications for Structural Concrete.
 - 2. ACI 308 - Standard Practice for Curing Concrete.

- B. American society for Testing and Materials (ASTM):
 - 1. ASTM A 185 - Specification for Steel Welded Wire, Fabric, Plain, for Concrete Reinforcement.
 - 2. ASTM A 615 - Specification for Deformed and Plain Billet-Steel Bars for Concrete Reinforcement.
 - 3. ASTM C 494 - Standard Specification for Chemical Admixtures for Concrete.
 - 4. ASTM C 618 - Standard Specification for Coal Fly Ash and Raw or Calcined Natural Pozzolan for Use as a Mineral Admixture in Concrete.
 - 5. ASTM D 1751 - Specification for Preformed Expansion Joint Fillers for Concrete Paving and Structural Construction (Nonextruding and Resilient Bituminous Types).

1.3 SUBMITTALS

- A. Section 013300 - Submittal Procedures: Procedures for submittals.
 - 1. Product Data: Submit product data for the following:
 - a. Joint filler.
 - b. Joint sealant.
 - c. Concrete admixtures.
 - d. Concrete curing compounds.
 - 2. Assurance/Control Submittals:
 - a. Concrete Mix Design: Submit three copies of each proposed mix design for each class of concrete in accordance with ACI 301, Sections 3.9 "Proportioning on the basis of previous field experience or trial mixture", or 3.10 "Proportioning based on empirical data". Submit separate mix design for concrete to be placed by pumping, in addition to the mix design for concrete to be placed directly from the truck chute.
 - b. Include the following information in concrete mix design:

- 1) Proportions of cement, fine and coarse aggregate, and water.
- 2) Water-cement ratio, 28-day compressive design strength, slump, and air content.
- 3) Type of cement and aggregate.
- 4) Aggregate gradation.
- 5) Type and dosage of admixtures.
- 6) Special requirements for pumping.
- 7) Range of ambient temperature and humidity for which design is valid.
- 8) Special characteristics of mix which require precautions in mixing, placing, or finishing techniques to achieve finished product specified.

1.4 QUALITY ASSURANCE

- A. Perform work in accordance with ACI 301.
- B. Conform to ACI 305R when mixing and placing concrete during hot weather.
- C. Conform to ACI 306R when mixing and placing concrete during cold weather.
- D. Regulatory Requirements:
 1. Conform to applicable requirements for paving work on public property.
 2. Contractor shall maintain access for vehicular and pedestrian traffic as required for other construction activities. Utilize temporary striping, flagmen, barricades, warning signs, and warning lights as required.

PART 2 - PRODUCTS

2.1 FORM AND REINFORCING MATERIAL

- A. Forms: Steel, wood, or other suitable material of size and strength to resist movement during concrete placement and to retain horizontal and vertical alignment until removal. Use straight forms, free of distortion and defects. Use flexible spring steel forms or laminated boards to form radius bends as required.
 1. APA Exterior Plyform BB with a medium density, smooth, hard, fused resin fiber overlay, or metal forms.
 2. Form Oil: Coat forms with non-staining type coating that will not discolor or deface surface of concrete. Subject to compliance with requirements, manufacturers offering specified items which may be incorporated in the work include the following.
 - a. "Eucoslip" - Euclid Chemical Co., Cleveland, OH (800) 321-7628.
 - b. "Form Coating" - Nox-Crete Chemicals, Omaha, NE (800) 669-2738.
 - c. Substitutions: Under provisions of Section 016000.
- B. Curb, Curb and Gutter Forms: Use flexible spring-steel forms or laminated boards to form radius bends. Tolerance: Not to deviate more than 1/4 inch in 10 feet in grade and alignment.
- C. Reinforcing:
 1. Welded Wire Mesh: Welded plain cold-drawn steel wire fabric, ASTM A 185. Furnish in flat sheets, not rolls, unless otherwise acceptable to Owner.
 2. Reinforcing Bars: Deformed steel bars, ASTM A 615, Grade 60.
 3. Fiber reinforced concrete mixtures having the same strength or exceeding as specified for concrete mixes, as verified by Manufacturer's testing laboratory procedures, shall be considered as an alternate for welded wire mesh in exterior flat work, curbs and sidewalks.
- D. Reinforcing Accessories:

1. Reinforcing Accessories: Subject to compliance with requirements, manufacturers offering specified items which may be incorporated in the work include the following.
 - a. Dayton Superior Corp., Miamisburg, OH (800) 745-3700.
 - b. Heckmann Building Products, Inc., Chicago, IL (800) 621-4140.
 - c. Hohmann & Barnard, Inc., Hauppauge, NY (800) 645-0616.
 - d. Richmond Screw Anchor Co., Inc., Ft. Worth, TX (817) 284-4981.
2. Conform to Concrete Reinforcing Steel Institute Manual of Standard Practice. Include spacers and chairs with plastic tipped legs, ties and other devices necessary for properly assembling, placing, spacing and supporting forms and reinforcement in place.
3. Section 016000 - Product Requirements: Product options and substitutions. Substitutions: Permitted.

2.2 CONCRETE MATERIALS

- A. Comply with requirements of applicable Section 033000 for concrete materials, admixtures, bonding materials, curing materials, surface sealers and others as required.
- B. Cement:
 1. Portland Cement: ASTM C150 Type 1.
 2. High-early Strength Portland Cement: ASTM C150, Type III.
- C. Aggregates: ASTM C33.
 1. Fine aggregate shall be natural sand, or sand prepared from stone or gravel. Grains shall; be clean, hard, durable, uncoated and free from silt, loam and clay.
 2. Coarse Aggregates: Crushed stone, gravel, or other approved inert materials of similar characteristics, or combinations thereof, having hard, strong, durable pieces free from adherent coatings. Maximum size of pieces shall be 3/4" to #4 except for footings, which may be 1-1/2". The maximum size of aggregate may also be not larger than one fifth of the narrowest dimension between forms, nor larger than three fourths of the minimum clear spacing between reinforcing bars.
- D. Water: Clean and free from injurious amounts of oil, acids, salts, organic or other deleterious matter.
- E. Air Entrainment: ASTM C260.
 1. Use air-entrained concrete for exterior exposed concrete including walls, walks, paving, etc. where minimum daily temperatures are expected below 38 degrees F during pouring or subsequent 38 day curing period.
 2. Proportion air-entraining concrete to attain minimum 28-day compressive strength specified.
 3. Total Air Entrainment in Concrete: Not less than four percent nor more than six percent volume of concrete.
- F. Admixtures:
 1. May be used at Contractor's option to provide workability at low slumps, increased compressive strength, retardation or acceleration of the concrete.
 2. Chemical Admixtures: ASTM C494. Mineral Admixtures: ASTM C618.
 3. The cement factor shall not be reduced and changes shall be made in the other mix proportions to ensure the minimum strength requirements.
 4. Use of admixtures approved in writing by Architect. No additional expense to the Owner will be allowed.
 5. No calcium chloride shall be used.
 6. Before any admixture is accepted for use, the Contractor shall submit certified laboratory reports on each additive material to the architectural consultant. The report shall show the following:
 - a. Confirmation of compliance with the applicable ASTM Standard.
 - b. Evaluation of the effects of the admixture on the properties of the concrete to be made on the job, including consideration of the anticipated ambient conditions on the job, and proposed construction procedures.

- c. Determination of within-lot uniformity of product proposed for use.

2.3 CONCRETE MIXES

A. Concrete Proportions:

1. Concrete shall be homogenous, and when hardened, shall have the required strength, resistance to deterioration, durability, water tightness and the properties as specified.
2. Minimum concrete strength at 28 days shall be;
 - a. 3,000 psi for walks, terraces, curbs and gutters.
 - b. 4,000 psi for concrete pavement and pads.
3. Slump of concrete:
 - a. Pavement: 2-1/2 inch minimum to 4 inch maximum.
 - b. Ramps and sloping surfaces: Not more than 3 inches.

B. Ready-Mix Concrete:

1. Ready-mix concrete shall conform to ASTM C94. The mixing agitation shall begin within 30 minutes, and the concrete shall be discharged from the truck within one hour after the water has been added to the concrete mix.
2. Delivery tickets are to accompany each concrete truck and shall be kept in the job superintendent's file. Delivery tickets must indicate the following information or be subject to rejection:
 - a. Name of project.
 - b. Supplier of concrete.
 - c. Truck identity and ticket serial number.
 - d. Date of delivery.
 - e. Brand of cement.
 - f. Cement content.
 - g. Strength classification.
 - h. Batching time.
 - i. Point of deposit.
 - j. Total amount of water.
 - k. Weight of aggregate.
 - l. Daily temperature.
 - m. Number of cubic yards in load.
 - n. Admixture content.
 - o. Name of Contractor.
 - p. Name of driver.
 - q. Time loaded and first mixing of concrete.
 - r. Reading of revolution counter.
3. Quantity of water used for each batch shall be accurately measured.

2.4 JOINT MATERIALS

- A. Sealed expansion and contraction joints: Filler of nonbituminous rubber or cork conforming to ASTM D1752.
- B. Non-sealed joints:
 1. Non-sealed Joints: Subject to compliance with requirements, manufacturers offering specified items which may be incorporated in the work include the following.
 - a. "Flexcell" - Celotex Corp., Tampa, FL (813) 873-1700.
 - b. "Seal Tight Fiber Expansion Joint" - W.R. Meadows, Inc., Hampshire, IL (800) 342-5976.
 2. Filler premolded bituminous type conforming to ASTM D1751.
 3. Section 016000 - Product Requirements: Product options and substitutions. Substitutions: Permitted.

- C. Noncompressive Filler:
1. Noncompressive Filler: Subject to compliance with requirements, manufacturers offering specified items which may be incorporated in the work include the following.
 - a. "Styrofoam SM" - Dow Chemical Co., Midland, MI (517) 636-0754.
 - b. "Foamular" - Owens Corning, Toledo, OH (800) 828-7155.
 2. 2 inch or 1 inch thick sheets.
 3. Section 016000 - Product Requirements: Product options and substitutions. Substitutions: Permitted.
- D. Compressive Filler:
1. Compressive Filler: Subject to compliance with requirements, manufacturers offering specified items which may be incorporated in the work include the following.
 - a. "Ethafaam" - Dow Chemical Co., Midland, MI (800) 322-8723.
 - b. "Rodofast" - Sternson Group, Brampton, ON (800) 265-8417.
 2. 2 inch or 1 inch thick sheets, compression modulus within the range of 15 to 25 pounds per square inch per inch.
 3. Section 016000 - Product Requirements: Product options and substitutions. Substitutions: Permitted.
- E. Filler Adhesive for Noncompressive Filler and Compressive Filler:
1. Filler Adhesive: Subject to compliance with requirements, manufacturers offering specified items which may be incorporated in the work include the following.
 - a. "General Purpose Mastic No. 11" - Dow Chemical Co., Midland, MI (800) 322-8723.
 - b. "Rodofast" - Sternson Group, Brampton, ON (800) 265-8417.
 2. Section 016000 - Product Requirements: Product options and substitutions. Substitutions: Permitted.
- F. Slab-on-grade Construction Joints: Provide a full slab depth 24 gauge metal preshaped key, approximate depth of key to be 1/4 slab thickness and a key width of about 1/10 slab thickness.
- G. Joint Sealants: ASTM C920. Non-priming, pourable, self-leveling polyurethane. Subject to compliance with project requirements manufacturers offering joint sealants which may be incorporated in the Work include, but are not limited to the following:
1. Sonolastic Paving Joint Sealant, by Sonneborn, Shakopee, MN (800) 433-9517.
 2. Sonomeric CT 1 Sealant, by Sonneborn, Shakopee, MN (800) 433-9517.
 3. Sonomeric CT 2 Sealant, by Sonneborn, Shakopee, MN (800) 433-9517.
 4. Vulkem 45, by Mameco, Cleveland, OH (800) 321-6412.
 5. Chem-Caulk, by Bostik, Middleton, MA (800) 726-7845.
 6. "THC-900" - Tremco, Beachwood, OH (800) 562-2728.
 7. Section 016000 - Product Requirements: Product options and substitutions. Substitutions: Permitted.

2.5 CURING MATERIALS

- A. Sealers:
1. Sealers: Subject to compliance with requirements, manufacturers offering specified items which may be incorporated in the work include the following.
 - a. "Polyseal" - W.R. Meadows, Inc., Hampshire, IL (800) 342-5976.
 - b. "Kure-N-Seal" - Sonneborn, Shakopee, MN (800) 433-9517.
 - c. "Cure-Hard" - W.R. Meadows, Inc., Elgin, IL (312) 683-4500.
 2. ASTM C156 and ASTM C309, Type I. Material shall become integral part of concrete and leave slab free of residue or film.
 3. Section 016000 - Product Requirements: Product options and substitutions. Substitutions: Permitted.
- B. Membrane: Opaque-white polyethylene sheet, 0.006 inch thick, meeting requirements of ASTM C171.

PART 3 - EXECUTION

3.1 EXAMINATION

- A. Section 017300 - Execution Requirements: Verification of existing conditions before starting work.
- B. Verification of Conditions: Verify that field measurements, surfaces, substrates and conditions are as required, and ready to for earthwork operations to begin.
 - 1. Verify gradients and elevations of base are correct, and base is dry.
- C. Report in writing to Contracting Officer prevailing conditions that will adversely affect satisfactory execution of the Work of this Section. Do not proceed with Work until unsatisfactory conditions have been corrected.
- D. By beginning Work, Contractor accepts conditions and assumes responsibility for correcting unsuitable conditions encountered at no additional cost to the United States Postal Service.

3.2 SUBGRADE PREPARATION

- A. Conform with the requirements specified in Section 312000 .
- B. Thoroughly wet subgrade and then compact with two passes of a 500 pound roller.
- C. Pumping: Where concrete paving or sidewalks, and curbs are to be placed, yielding material deflecting more than 1/2 inch under a 500 lb. roller shall be removed to a depth of not less than 4 inches below subgrade elevation and replaced with an approved granular material which shall then be compacted as described above.
- D. The subgrade shall be in a moist condition when the concrete is placed. In cold weather the subgrade shall be prepared and protected so as to provide a subgrade free from frost when the concrete is deposited.

3.3 FORM CONSTRUCTION

- A. Comply with the requirements of Section 033000. Install sufficient quantity of forms to allow continuous progress of the work and so that forms can remain in place at least 24 hours after concrete placement.
- B. Check complete formwork for grade and alignment to the following tolerances:
 - 1. Top of form: Not more than 1/8 inch in 10 feet.
 - 2. Vertical face: Longitudinal axis not more than 1/4 inch in 10 feet.

3.4 PLACING REINFORCEMENT

- A. Support reinforcing and wire securely together to prevent displacement by construction loads and traffic, or the placing of concrete. For slabs on grade, supporting pieces of concrete blocks or bricks may be used.
- B. Place wire mesh reinforcing two inches above bottom of slab unless otherwise indicated.
- C. Reinforcement shall be kept clean from oil, dirt and loose mill scale or other coatings which might destroy the concrete bond. Remove tags and markings prior to concrete placement.

- D. Do not place concrete until reinforcement has been inspected and approved by local authorities, if required.

3.5 CONCRETE PLACEMENT AND FINISHING

- A. Tamp and consolidate concrete with a suitable wood or metal tamping bar and the surface shall be finished to grade with a wood float.
- B. Finished surfaces shall not vary more than 3/16 inch from the testing edge of a 10 foot straightedge.
- C. Curb Expansion Joints: Fill joints with 1/2 inch thick joint filler strips conforming to ASTM D1751 or ASTM D1752.
- D. Contraction Joints: Divide the surface of paving, walks and terraces into rectangular areas not to exceed 5 feet 0 inches each way.
 - 1. Cut a groove in the top portion of the slab to a depth of at least one-fourth of the slab thickness using a jointer or by sawing a groove in the hardened concrete with a power-driven saw.
 - 2. Membrane-cured surface damaged during the sawing operations shall be resprayed as soon as the surface becomes dry.
- E. Slab Finishes: ACI 301, paragraph 11.7 and as follows:
 - 1. Broom Finish: On stair treads with abrasive nosings and on walks, unless other finishes have been indicated or specified.
 - 2. Broom or Belt Finish: On level walks. Broom in direction perpendicular to travel and approved sample panel. Submit joint pattern layout prior to starting work.

3.6 TOLERANCES

- A. Horizontal slabs: Finished surfaces true with no deviation in excess of 1/8 inch when tested with a 10 foot straightedge, non-accumulative. No coarse aggregate showing.
- B. Steps:
 - 1. Variation in steps within a flight of stairs:
 - a. Rise: 1/8 inch.
 - b. Tread: 1/4 inch.
 - 2. Variation in consecutive steps:
 - a. Rise: 1/16 inch.
 - b. Tread: 1/8 inch.

3.7 EXPANSION JOINTS

- A. Install transverse expansion joints at returns and 15 feet on center.
- B. Install longitudinal expansion joints where curbs and paved areas abut each other, buildings, other concrete slabs and pads or vertical restraints.
- C. Place joint filler with top edge 1/4 inch below the surface and shall be held in place with steel pins or other devices to prevent warping of the filler during floating and finishing.
- D. Immediately after finishing operations are completed, round joint edges with edging tool having a radius of 1/8 inch. Remove concrete over the joint filler.
- E. At the end of the curing period, clean and fill expansion joints with joint sealer. Fill joints flush with concrete surface. Dummy groove joints shall not be sealed.

3.8 CURING

- A. Immediately after the finishing operations, the exposed concrete surface shall be cured for 7 days by the mat, impervious sheet, or membrane-curing method.

3.9 BACKFILLING

- A. After curing, remove debris and backfill the adjoining areas, grade and compact to conform to the surrounding area in accordance with the lines and grades indicated.

3.10 PROTECTION

- A. Protect the completed work from damage. Repair damaged concrete and clean concrete discolored during construction. Remove work that is damaged and reconstruct to entire length between regularly scheduled joints. Refinishing damaged portion is not acceptable.
- B. Prevent cars and trucks from driving on new pavement for a minimum of 14 days.

END OF SECTION

USPS MPF Specification Last Revised: 10/1/2022

SECTION 321723
PAVEMENT MARKINGS

PART 1 - GENERAL

1.1 SUMMARY

- A. Section Includes:
 - 1. Painted pavement markings.
 - 2. Painted curbs.
- B. Related Documents: The Contract Documents, as defined in Section 011000 - Summary of Work, apply to the Work of this Section. Additional requirements and information necessary to complete the Work of this Section may be found in other Documents.
- C. Related Sections:
 - 1. Section 321216 - Asphalt Paving: Asphalt paving substrate for marking application.
 - 2. Section 321313 - Concrete Paving: Concrete paving substrate for marking application.
 - 3. Section 099100 – Painting: Painting exterior bollards.

1.2 SUBMITTALS

- A. Section 013300 - Submittal Procedures: Procedures for submittals.
 - 1. Product Data: Technical data sheets indicating manufacturer's catalog number, paint type description, and VOC content for each paint type specified.
 - 2. Assurance/Control Submittals:
 - a. Certificates: Manufacturer certificate that Products meet or exceed specified requirements.
 - b. Test Reports: Manufacturer Material Safety Data Sheets (MSDS) for each paint type specified.

1.3 QUALITY ASSURANCE

- A. Regulatory Requirements: Provide paint materials that conform to Federal, State, and local restrictions for Volatile Organic Compounds (VOC) and lead-free content.

1.4 DELIVERY, STORAGE AND HANDLING

- A. Section 016000 - Product Requirements: Transport, handle, store, and protect products.
- B. Deliver paint materials in sealed original labeled containers, bearing manufacturer's name, type of paint, brand name, lot number, brand code, coverage, surface preparation, drying time, cleanup requirements, color designation, and instructions for mixing and/or reducing.
- C. Store paint materials at minimum ambient temperature of 45 degrees F and a maximum of 90 degrees F, in ventilated area, and as required by manufacturer's published instructions.

1.5 PROJECT CONDITIONS OR SITE CONDITIONS

- A. Maintain access for vehicular and pedestrian traffic as required for other construction activities. Utilize flagmen, barricades, warning signs and warning lights as required.

1.6 MAINTENANCE

- A. Section 017704 – Closeout Procedures and Training: Requirements for Closeout Submittals.
 - 1. Extra Materials:
 - a. Provide 1 gallon of each color to Contracting Officer.
 - b. Label each container with color and type, in addition to manufacturer's label.

PART 2 - PRODUCTS

2.1 MANUFACTURERS

- A. Subject to compliance with project requirements, manufacturers offering specified Products which may be incorporated into the Work include the following:
 - 1. Sherwin-Williams Company, Cleveland, OH (800) 321-8194.
 - 2. Benjamin Moore and Company, Montvale, NJ (201) 573-9600.
 - 3. Pittsburgh Paints (PPG), Pittsburgh, PA (800) 441-9695.
- B. Section 016000 - Product Requirements: Product options and substitutions. Substitutions: Permitted.

2.2 MATERIALS

- A. Ready-mixed; pigments fully ground maintaining a soft paste consistency, capable of readily and uniformly dispersing to a complete homogeneous mixture providing good flowing and brushing properties capable of drying or curing free of streaks or sags. Dry to traffic and touch in 2 hours.
- B. Traffic Paint: Flat, Water Base, Acrylic, complying with Federal Specifications TT-P 1952D
 - 1. 1st Coat:
 - a. Sherwin-Williams: Pro-Park Waterborne Traffic Marking Paint, B97 Series MDF 9 mils.
 - b. Benjamin Moore: SuperSpec HP Safety & Zone Marking Paint P58, MDF 9 mils
 - c. PPG Zoneline Traffic & Marking Paint, 11-50 Series, MDF 9 mils.
 - 2. 2nd Coat:
 - a. Sherwin-Williams: Pro-Park Waterborne Traffic Marking Paint, B97 Series MDF 9 mils.
 - b. Benjamin Moore: SuperSpec HP Safety & Zone Marking Paint P58, MDF 9 mils
 - c. PPG Zoneline Traffic & Marking Paint, 11-50 Series, MDF 9 mils.

PART 3 - EXECUTION

3.1 EXAMINATION

- A. Section 017300 - Execution: Verification of existing conditions before starting work.
- B. Verification of Conditions: Verify that field measurements, surfaces, substrates and conditions are as required, and ready to receive Work.
- C. Report in writing to Contracting Officer prevailing conditions that will adversely affect satisfactory execution of the Work of this Section. Do not proceed with Work until unsatisfactory conditions have been corrected.

- D. By beginning Work, Contractor accepts conditions and assumes responsibility for correcting unsuitable conditions encountered at no additional cost to the United States Postal Service.

3.2 PREPARATION

- A. Sweep pavement and surfaces to receive paint markings clean of dust and dirt. Allow pavement to cure a minimum of 60 days prior to application of paint markings.
- B. Clean surfaces free of glaze and grease, road film, and other foreign materials.
- C. Where existing pavement markings are indicated on Drawings to be removed or would interfere with the adhesion of new paint, use a motorized abrasive device to remove existing markings.
 - 1. Use equipment that will not damage existing paving or create surface hazardous to vehicle or pedestrian traffic.
 - 2. Use marking removal methods approved by governing authority having jurisdiction in areas within public rights-of-way.

3.3 APPLICATION

- A. Apply paint products in accordance with manufacturer's published instructions using application procedures approved for the particular application and substrate to the specified Minimum Dry Film Thickness (MDF). Apply each coat to uniform finish.
- B. Do not apply paint markings on surfaces that are not dry and if rain is expected within 24 hours.
- C. Do not apply paint markings when surface or air temperature is below 50 degrees F.
- D. Apply 2 coats at manufacturer recommended rate without addition of thinner. Apply with mechanical equipment to produce uniform straight edges. At sidewalk curbs and crosswalks, use straightedge to provide uniform, clean, and straight stripe.

3.4 PAINT MARKING SCHEDULE

- A. Paint the following items with colors indicated below:
 - 1. Pedestrian Crosswalks: Per existing color.
 - 2. Fire Lanes: Red or per local code.
 - 3. Lane Striping Where Separating Traffic in Opposite Directions: Yellow.
 - 4. Lane Striping Where Separating Traffic in Same Direction: White.
 - 5. Handicap Symbols: Per local code.
 - 6. Parking Stall Striping: Per existing color.

END OF SECTION

USPS MPF Specification Last Revised: 10/1/2022